

**UUN - TROL**

**CE**

**OLA**

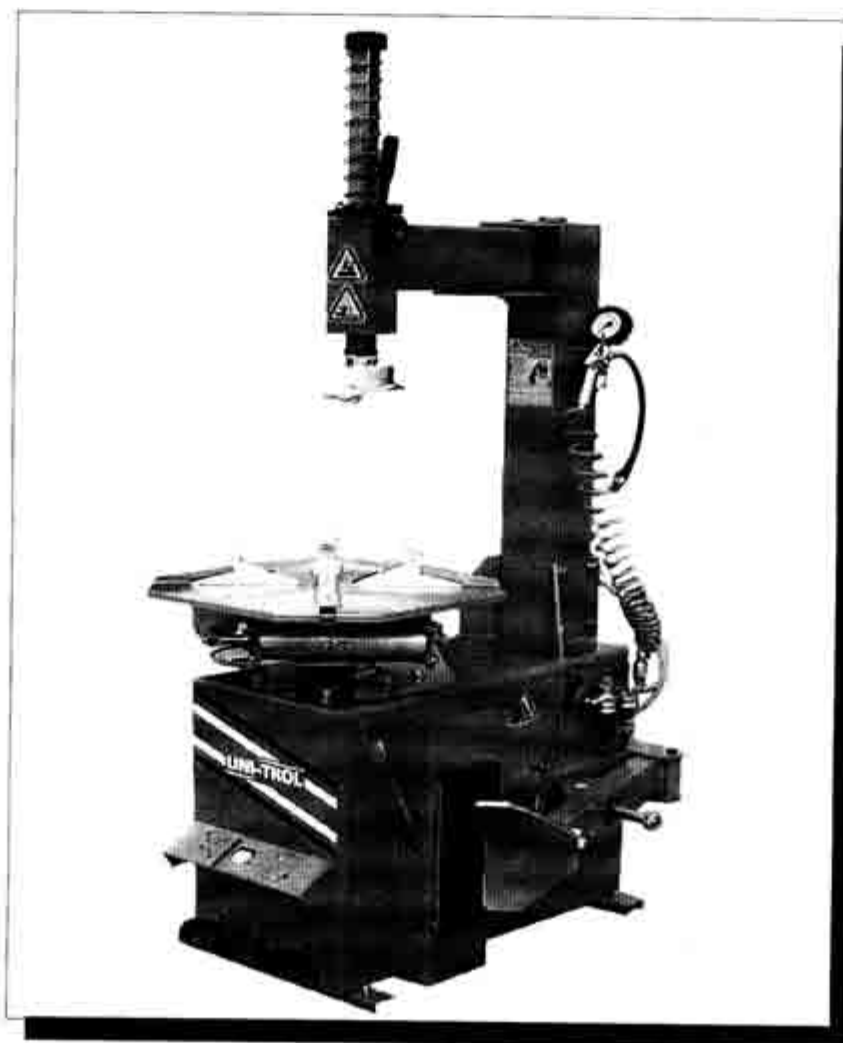

**OPERATING INSTRUCTION**

# UNI-TROL

COMPUTER BALANCERS  
DIAGNOSTIC EQUIPMENT  
WORKSHOP EQUIPMENT

UNI - TROL Sp. z o.o.

Mościska 8A k. Warszawy  
05 - 080 Izabelin  
tel . (0-22) 834-90-14  
tel ./ fax 834-90-13

\*\*\*\*\*  
PRODUCTION FACILITY - SALES SHOWROOM - FACTORE SERVICE:  
01-932 Warszawa, ul.Estrady 56 tel./fax : (0-22) 834-90-14 , (0-22) 834-90-13  
\*\*\*\*\*

# 1. GENERAL

Tyre changer OLA is designed for mounting and demounting of tubed and tubeless car and van wheels tyres. It may also be used for servicing light-alloy, as its working components will not damage the delicate of such wheels.

OLA performs the following:

In standard version:

- separation of tyre from wheel rim
- mounting and demounting tyres
- inflation of tyres by means of a gun with pressure gauge

Additionally machine can be equipped:

- surge inflation of tubeless tyres ( type OLA IT )

## TECHNICAL DATA

- |                                  |                        |
|----------------------------------|------------------------|
| - tyre diameter range            | - to 23 inches         |
| - max.tyre width.                | - 12 inches            |
| - tyre clamping to machine table | - pneumatic            |
| - recommended air supply         | - from 0,8 to 1,0 MPa  |
| - electric power supply          | - 3 x 380V / 50Hz      |
| - active power                   | - 0,8 kVA              |
| - motor power                    | - 0,75 kW              |
| - bead breker power              | - 1,5 tonnes (at 1MPa) |
| - required floorspace            | - 800 x 900 mm         |
| - height                         | - 1450 mm              |
| - weight                         | - abt. 180 kg          |
| - table speed                    | - 7 r.p.m.             |

## 2. INSTALLATION

- 1.Install the machine on a hard flat surface.
- 2.Connect power cable to 3x380V/50Hz mains socket.

3. Connect compressed air supply hose to air supply union ( item 1, Fig.1.) Use a pneumatic hose rated min. 1 MPa working pressure, inside diameter 8mm . Check if lubricator 5 is filled with oil. Depressing pedal 16 check if clamping joints move.

**NOTE:**

Periodically, top-up compressed air lubricator ( item 4, Fig 1 ) with oil. .

In the lubricator lid there are two screw: the smaller one for adjusting lubrication rate and the bigger one for closing oil filler, through which oil may be added by means of a syringe. The transparent bowl may be carefully unscrewed from the lubrication body and filled directly with oil. Use mineral oils, free of water and acids, 2 to 4 E viscosity ( at 50 C) .

Hydraulic oil HL32 is recommended.

Air filter/drier is maintenance-free, it is self-cleaning.

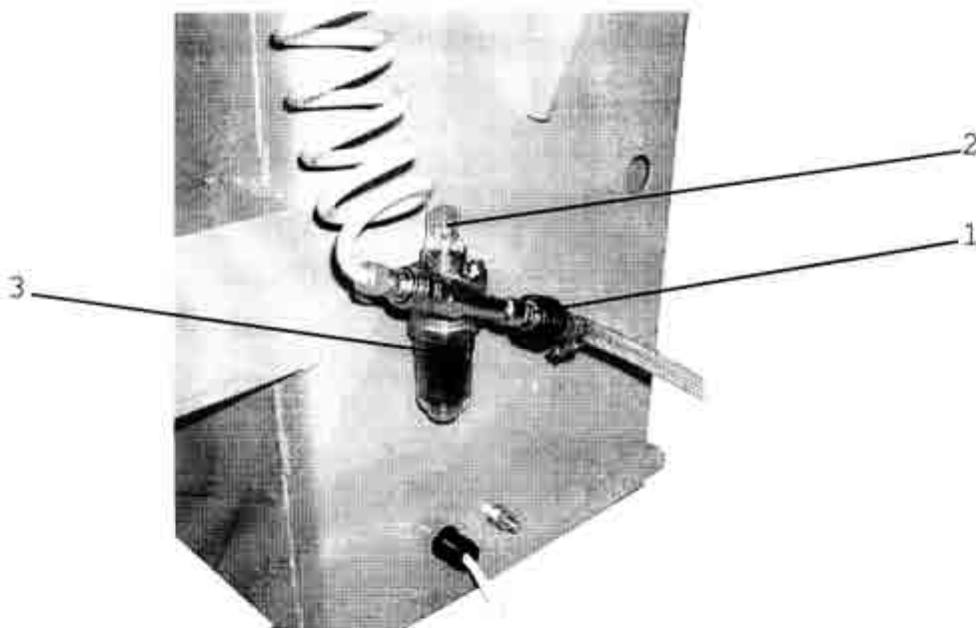

**Fig.1. Connections**

1- compressed air supply union, 2-inflation union, 3- compressed air filter/drier,

### 3. DESCRIPTION

OLA tyre changer is provided with an elektro - pneumatic drive. Separation of tyre from wheel rim and clamping the wheel to the table is accomplished by means of pneumatic cylinders.

The machine table is rotated by means of an electric motor.

Major components of the machine are shown in Figs 2,3,4,5.

**Fig. 2. Major machine components**

- 5- control pedals
- 7- table
- 8-table jaw
- 9- column
- 10- head slide
- 11- head arm
- 12- bead breaker
- 13- tyre inflation gun

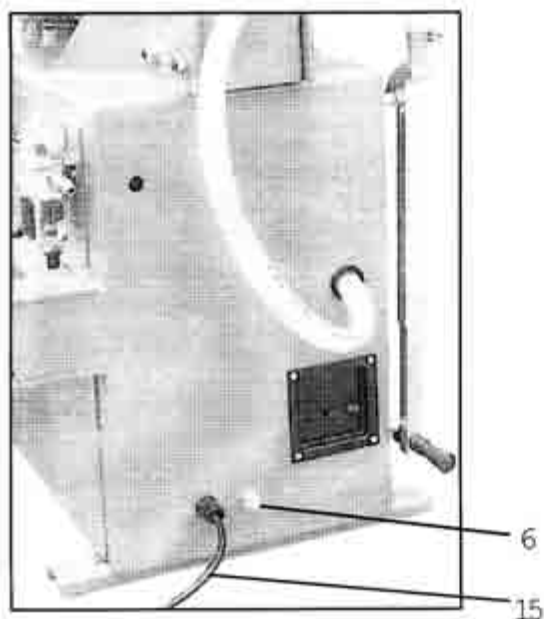
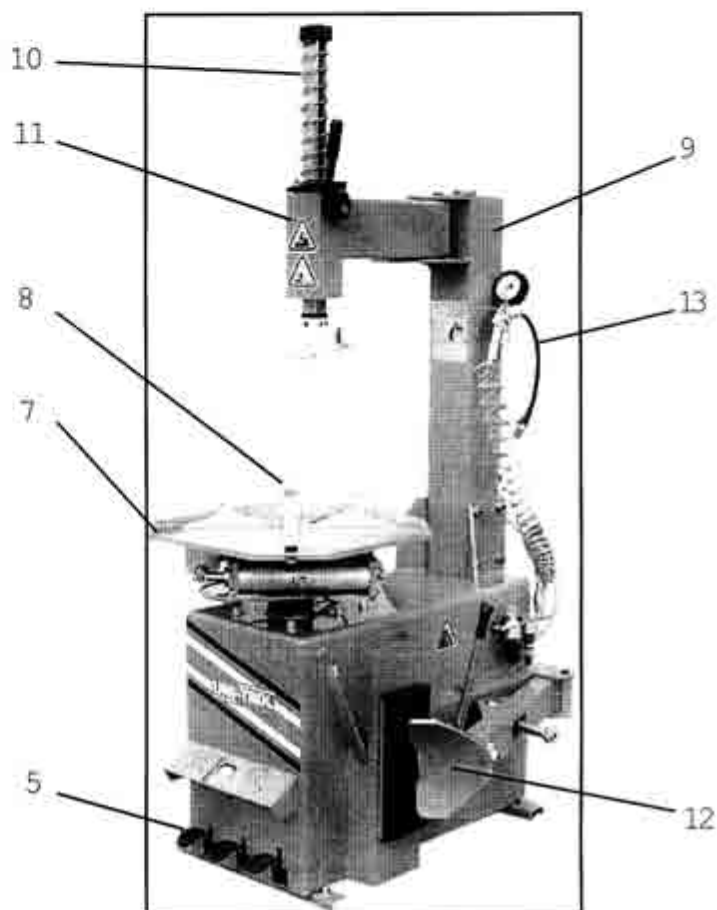

**Fig. 3. Rear wall view**

- 6- additional protective terminal
- 15- power supply cable

## MACHINE CONTROLS

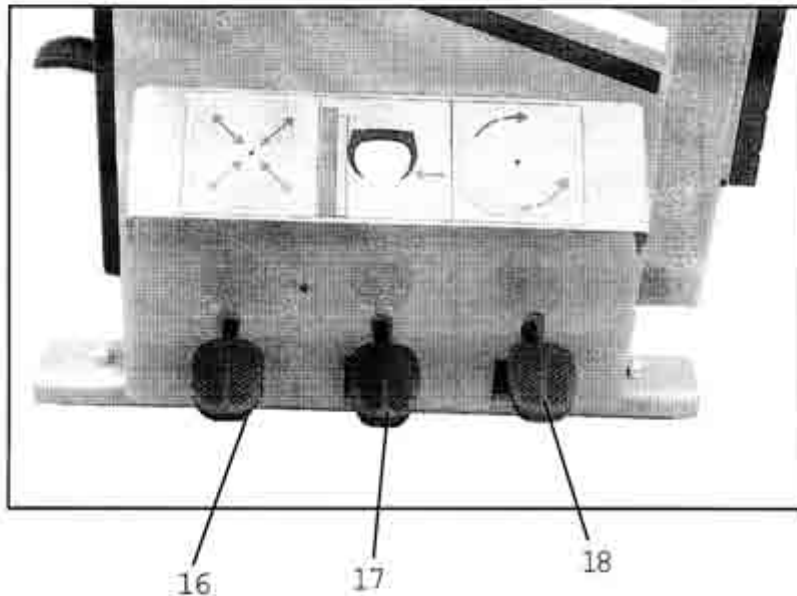

Fig. 4. Control pedals

### Wheel Clamping Pedal (item 16)

Controls inward and outward travel of table jaws. It has three working position

- 1- Top position -jaws closed (towards table centre)
- 2-Central position - outward movement of jaws to any distance.

How to operate the pedal in centre position:

- depress pedal with feeling, until snap is heard
  - release pedal to lock in central position
  - subsequent depression of pedal will result in outward travel of jaws and its release- in stopping the travel. Depress pedal carefully to avoid its overshooting to bottom position.
3. Bottom position- full jaw outward travel. Subsequentde pression of pedal resets it to top position (jaws closed)

### Bead Breaker Pedal (item.17)

Has two working positions:

- 1- top (intitial) - bead breaker disengaged,
- 2- depressin gpedal engages bead breaker-releasing pedal disengages bead breaker

### Table Rotation Pedal (item.18)

Has three working positions:

- 1-central position ( initial) - table drive disengaged.
- 2-depressing pedal engages clockwise table rotation ( working rotation), releasing pedal disengages table rotation

3- lifting up pedal ( with foot) from central position engages anticlockwise table rotation (emergency rotation), releasing pedal disengages rotation.

### Arm Position Adjustment Knob ( item19)

Used to adjust clearance between foot and wheel rim ( see Fig.8). Nut 20 is used to lock the arm in desired position.

### Slide Locking Lever ( item 20)

Pressing slide end 10 down we move the foot closer to the wheel rim.  
Shifting the lever upwards results in locking the slide in the working position.

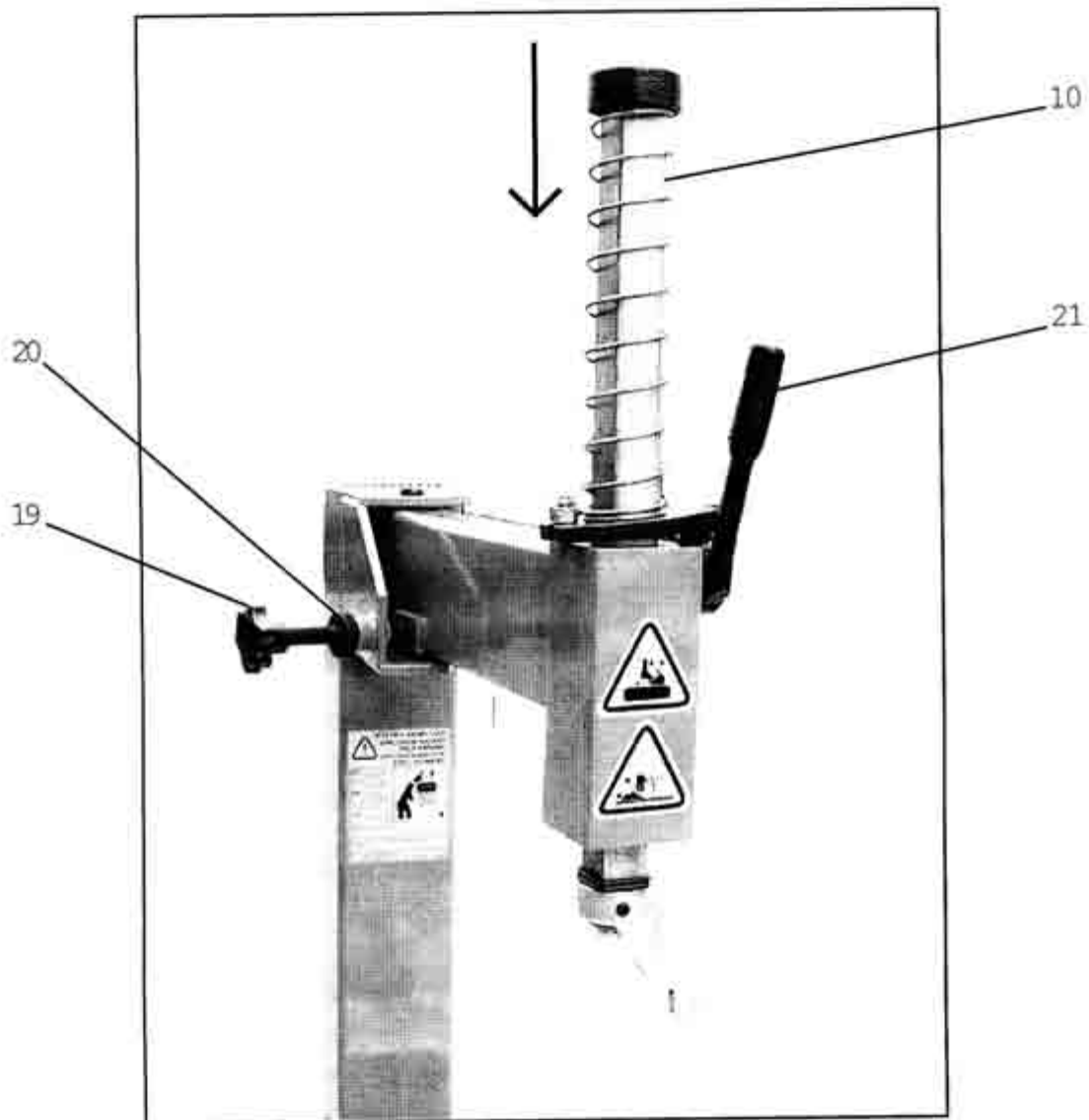

**Fig. 5. View of Working Head**

10- head slide 19- arm position adjustment knob  
20-lock nut, 21- head slide locking lever

## 4. REMOVING TYRES

Turn power and air supply of the machine on.

Pull away, by hand, bead breaker lever 22, place wheel between bead breaker arm and rubber pad on machine wall and bring arm against tyre, directly next to wheel rim edge.

**ATTENTION: ARM MUST NOT REST AGAINST RIM!**

Holding bead breaker arm in appropriate position, depress bead breaker pedal 17 and hold it down until the tyre is separating from rim. If necessary, repeat this operation at several **points** of the wheel circumference.

Next, turn the wheel over and, in the same way, separate the tyre from the rim on the other side.

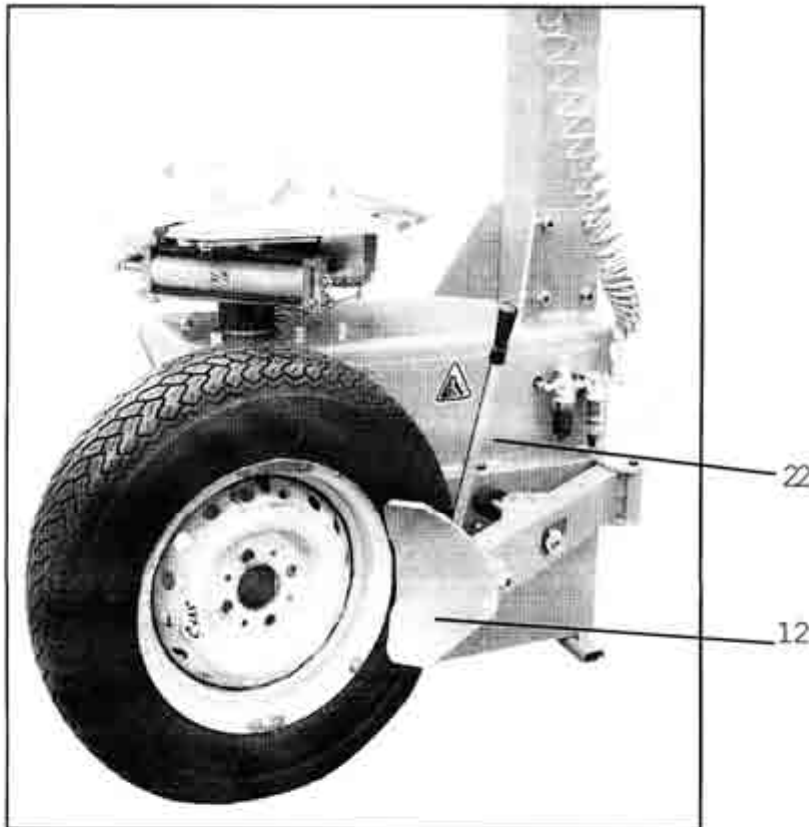

**Fig. 6. Tyre separation**  
12- bead breaker arm  
22- bead breaker lever

Move head arm 11 left to take it clear of the wheel.

By means of pedal 16 open table jaws (pedal in central or bottom position). Place wheel on machine table so that the tyre rests on the jaws and shift 16 to top position.

Check if jaw hitches grip rim edge securely.

Grip, with left hand, the top of slide 10 and with right hand - slide locking lever 21 by turning the arm to the left, bring the foot to contact with rim edge, as shown in Fig.8. Then, lift the foot slightly above rim edge to obtain adequate vertical clearance and shift lever 21 upwards-the slide will lock.

By means of knob 19 set horizontal clearance between wheel and foot and lock the knob with nut 20.

Press bead tyre opposite the foot into wheel rim recess. Rest tyre lever on foot support 23 and pull bead tyre onto bulb 24-as shown in Figs 9 and 10.



**Fig. 7. Foot parts:**  
23- support,  
24- bulb,  
25- slide

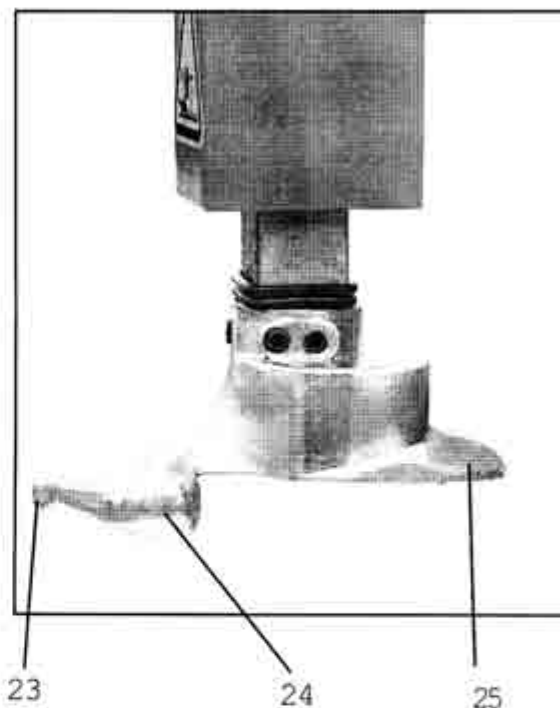

**Fig. 8. Foot in working position**

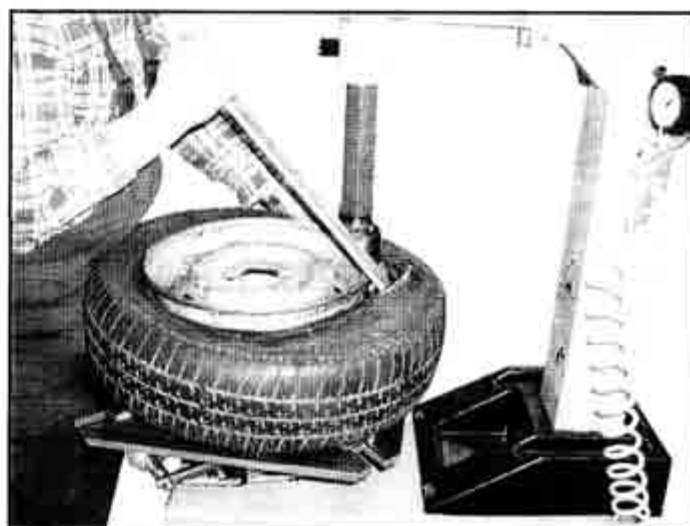

**Fig. 9. Pulling bead tyre edge onto bulb**



**Fig. 10. Tyre demounting**

Rotate machine table clockwise, by depressing pedal **18**, until the bottom tyre edge fits in the wheel rim. In the case of problems during tyre removal, e.g. jamming, release pedal and subsequently lift it, with your foot, up. Then the table will rotate anticlockwise and it will release the jammed tyre.

The bottom tyre edge is removed from the wheel rim without unclamping the wheel or altering the position of the foot. It is enough to remove the tube, push the bead tyre, opposite the foot, into wheel rim recess and repeat tyre removal operation, as described above.

Shift lever **21** downwards to release slide. The foot will lift up. Shift, by hand, arm **21** to the right, so that it does not interfere with work being done on the table. Put tyre away. Open table jaws with pedal **16** and remove rim from the machine.

## **5. FITTING TYRES**

Shift arm **11** to the right.

By means of pedal **16**, open table jaws (pedal in central position or bottom position). Place wheel rim on machine table and shift pedal **16** to top position. Check if jaws grip rim edge securely.

Place tyre on rim.

Grip, with your left hand, the top of slide **10** and, with your right hand, slide locking lever **21**. Moving the slide by an appropriate distance and turning the arm to the left, rest the foot against rim edge, as shown in Fig.8. Then, lift the foot slightly above rim edge, in order to obtain adequate vertical clearance, and shift lever **21** upwards-the slide will lock.

By means of knob **19**, set horizontal clearance between rim and foot and lock knob with nut **20**.

Press bottom tyre edge, opposite the foot, into wheel rim recess. Place the opposite tyre edge on the foot slide **25** press under bulb **24**-as shown in Fig.11.



**Fig.11.**

## **WARRANTY**

All repairs and adjustments are carried out by the manufacturer. Repair of the machine by the user results in loss warranty.

## TABLE OF CONTENTS

1.GENERAL	str. 3
2.INSTALLATION	str. 3
3. DESCRIPTION	str. 5
4. DEMOUNTING TYRES	str. 8
5. MOUNTING TYRES	str. 10
6.NOTES ON OPERATION	str. 11
. WARRANTY	str. 13

WHEEL BALANCING MACHINES

TYRE CHANGERS

EQUIPMENTS FOR TYRESHOPS

Statistic number : 008132994

Tax number : 527 - 020 - 52 - 46

## CE Conformity Declaration

in accordance with directives : 98/37/CE and 89/336/CEE

We :

**Uni-trol Co. Ltd.**  
**Ul. Estrady 56**  
**01-932 Warsaw**  
**Poland**

declare, under our exclusive responsibility, that the product

### Tyre changer type **OLA**

version standard

to which this declaration refers, is in conformity with the following provisions of law :

- directive 98/37/CE ( the safety of machinery );
- directive 89/336/CEE and following modifications ( the electromagnetic compatibility ).

For verification of conformity with the provisions of law were consulted the harmonized standards or other norms documents :

- |                            |   |
|----------------------------|---|
| - PN - EN 292 - 1 / 2000   | Basic concepts, general principles for design - Part 1;   |
| - PN - EN 292 - 2 / 2000   | Basic concepts, general principles for design - Part 2;   |
| - PN - EN 50081 - 1 / 1996 | Generic emission standard, residential, commercial and light industry;                              |
| - PN - EN 50081 - 2 / 1996 | Generic emission standard, industrial environment;  |
| - PN - EN 50082 - 1 / 1999 | Generic immunity standard, residential, commercial and light industry;                              |
| - PN - EN 50082 - 2 / 1997 | Generic immunity standard, industrial environment;  |
| - PN - EN 294 / 1994       | Safety distances to prevent danger zones being reached by the upper limbs;                          |
| - PN - EN 349 / 1999       | Minimum gaps to avoid crushing of parts of the human body;  |
| - PN - EN 61293 / 2000     | Marking electrical equipments with ratings to electrical supply - Safety requirements.              |
| - 62 / 2002                | Electrical accessories;   |
| - PN - EN 983 / 1999       | Safety of machinery - Safety requirements for fluid power systems and their components - Pneumatics |

This declaration is valid for all products which are produced in accordance with the technical documentation which is part of this declaration.

Wieslaw Roguski  
Chairman of Board

Warsaw, 01.05.2004

"UNI - TROL" Sp. z o.o.  
ul. Estrady 56, 01-932 Warszawa  
tel./fax (+48 22) 834-90-13, 834-90-14  
tel. (0-22) 817-94-22  
NIP: 527-020-52-46

Signature