

**TYRE-CHANGER FOR CARS**

**OLA**

**OPERATING MANUAL**

**Production-Sales-Service**

**UNI-TROL Sp. z o.o.**

**Ul. Estrady 56**

**01-932 Warszawa**

**Tel/fax (+48 22 ) 8179422, 8349013, 8349014**

**Serial numer** \_\_\_\_\_

**Production year** \_\_\_\_\_

**MANUFACTURER and AUTHORISED SERVICE CENTER:**

**UNI-TROL Sp. z o.o.**

**Ul. Estrady 56**

**01-932 Warszawa**

**Tel/fax (+48 22 ) 8179422, 8349013, 8349014**

# **CONTENTS**

<b>INTRODUCTION.....</b>	<b>4</b>
<b>1. TRANSPORT, STORAGE, PACKING.....</b>	<b>5</b>
<b>2. INSTALLATION PLACE.....</b>	<b>5</b>
<b>3. ELECTRIC AND PNEUMATIC CONNECTIONS.....</b>	<b>6</b>
<b>4. SAFETY.....</b>	<b>6</b>
<b>5. EQUIPMENT DESCRIPTION.....</b>	<b>7</b>
<b>6. CONTROLLING ELEMENTS.....</b>	<b>8</b>
<b>7. TYRE DEMOUNTING.....</b>	<b>11</b>
<b>8. TYRE MOUNTING.....</b>	<b>14</b>
<b>9. TYPICAL FAULTS AND REPAIRS.....</b>	<b>15</b>
<b>10. WARRANTY.....</b>	<b>16</b>
<b>11. MAINTENANCE /SCRAPING.....</b>	<b>16</b>

## **INTRODUCTION**

This manual has been prepared for workshop personnel expert in the use of the tyre changer (operator) and technicians responsible for routine maintenance (maintenance fitter); read the manual before carrying out any operation with the tyre-changer and/or the packing. This manual contains important information regarding:

- **THE PERSONAL SAFETY of operators and maintenance workers,**
- **TYRE CHANGER SAFETY,**

### **CONSERVING THE MANUAL**

The manual is an integral part of the tyre-changer, which it should always accompany, even if the unit is sold.

The manual must be kept in proximity of the tyre changer, in an easily accessible place.

The operator and maintenance staff must be able to locate and consult the manual quickly and at any time.

**ATTENTIVE AND REPEATED READING OF CHAPTER “SAFETY”, CONTAINING IMPORTANT INFORMATION AND SAFETY WARNINGS, IS PARTICULARLY RECOMMENDED.**

Lifting, transport, unpacking, assembly, installation, starting up, initial adjustment and testing, extraordinary maintenance, repair, overhauls, transport and dismantling of the tyre-changer must be performed by personnel from the LICENSED DEALER or a SERVICE CENTRE authorized by the manufacturer.

The manufacturer declines all responsibility for injury to persons or damage to vehicles or objects when any of the above mentioned operations has been performed by unauthorized personnel or when the tyre-changer has been subject to improper use.

## **1. TRANSPORT, STORAGE, PACKING.**

ALL PACKING, LIFTING, HANDLING, TRANSPORT AND UNPACKING OPERATIONS ARE TO BE PERFORMED EXCLUSIVELY BY EXPERT PERSONNEL WITH KNOWLEDGE OF THE TYRE-CHANGER AND THE CONTENTS OF THIS MANUAL

The tyre-changer is sent on pallets, covered with stretch foil or stretch foil and carton box. The pallets must be moved with a lift truck. The equipment chosen must be suitable for safe lifting and moving, bearing in mind the dimensions, weight, barycentre, juts, and fragile parts not to be damaged.

Packed machinery must always be kept in a covered, protected place, at a temperature between -25 °C - + 55°C, and must not be exposed to direct sunlight.

The wood of the pallets and the package carton may be re-used or recycled.



## **2. INSTALLATION PLACE**

The tyre-changer is designed for installation in enclosed areas suitably protected from the weather. The place of installation must be well clear of areas destined to washing or painting, and away from solvent or paint storage areas or areas where there is a risk of potentially explosive atmosphere.

The tyre-changer must be installed in observance of the clearances between walls, pillars, other machines, etc. in compliance with any legislative requirements in the country of installation. Check in particular that the distance from walls is enough to permit an easy access to every part of the machine, a good moving of tyres, a good and wide working area for the operator, and at least, 500 mm for a possible way of escape in case of danger. Check also proximity to power supply and pneumatic connection for trouble-free hook-up.

### **Environmental working conditions:**

- Humidity 30% - 95 %
- Temperature from 0°C - 55°C

### **3. ELECTRIC AND PNEUMATIC CONNECTIONS.**

The operations listed below must be performed by skilled personnel.

Before connecting the electric plant, make sure that:

- the power supply plant to the tyre-changer is equipped with the protection devices by current standards in the country where the machinery is installed.
- the power supply line has the following characteristics:

Tyre-changer voltage: 400V 3-ph. min. 2,5 mm<sup>2</sup>

- voltage oscillations are within the tolerance range set forth by the specification.

Connect the tyre-changer to a socket with fuses and voltage difference save-life switch.

Connect a compressed air source with a pression between 8 and 10 bar.

### **4. SAFETY.**

It is vital to read this chapter of the manual carefully and from beginning to end as it contains important information regarding the risks that the operator or maintenance fitter may be exposed to in case of improper use of the tyre-changer. The following text contains clear explanations regarding some situations of risk or danger that may arise during the operation or maintenance of the tyre-changer, the safety devices installed and the correct use of such systems, residual risks and operative procedures to use (general and specific precautions to eliminate potential hazards).

Tyre-changer is designed and built as a tool to change tyres on car, motorcycles, or vans wheel rims. All other uses are unauthorized.

The manufacturer disclaims all liability for injury to persons or damage to vehicles and other property caused by the incorrect and unauthorized use of the tyre-changer.

The operator must remain in the command place in the respect of all the rules listed below. The presence of persons inside the danger zone is strictly prohibited during the tyre-changer working operations.

**DO NOT USE THE TYRE CHANGER WITHOUT PROTECTION DEVICES OR WITH THE PROTECTION DEVICES INHIBITED. FAILURE TO COMPLY WITH THESE REGULATIONS CAN CAUSE SERIOUS INJURY TO PERSONS, AND IRREPARABLE DAMAGE TO THE TYRE-CHANGER.**

#### **GENERAL PRECAUTIONS**

The operator and the maintenance fitter are required to observe

the prescriptions of accident prevention legislation in force in the country of installation of the tyre-changer.

Furthermore, the operator and maintenance fitter must:

- Always work in the scheduled working area as shown in the manual.
- Never remove or deactivate the guards and mechanical, electrical or other types of safety devices;
- Read the safety notices affixed to the machine and the safety information in this manual.

In the manual all safety notices are shown as follows:

**DANGER:** Indicates imminent danger that can result in serious injury or death.

**WARNING:** Indicates situations and/or types of manoeuvres that are unsafe and can cause injuries of various degrees or death.

**ATTENTION:** Indicates situations and/or types of manoeuvres that are unsafe and can cause minor injury to persons and/or damage the tyre-changer, the vehicle or other property.

## **5. EQUIPMENT DESCRIPTION.**

The tyre-changer OLA is a semi-automatic machine, designed and built as tool for changing tyres on cars, motorcars or vans wheel rims. It may also be used for servicing light-alloys rims because the working elements of the machine will not damage the delicate rim structure. The machine is equipped in electro-pneumatic drive. Turntable is rotated by an electro-motor.

In standard version the tyre-changer

- Separate the tyre from the wheel rim;
- Mount and demount tyres;
- Inflate the tyre by a gun with pressure gauge.

### **TECHNICAL DATA:**

- **Tyre diameter range – till 23”**
- **Max. tyre width – 12”**
- **Tyre clamping to machine table – pneumatic**
- **Recommended air supply –from 0,8 MPa till 1,0 MPa**
- **Electric power supply – 3 x 400 V / 50 Hz**
- **Motor power – 0,75 kWa**
- **Bead breaker power – 1,5 tonnes (at 1MPa)**
- **Required floorspace – 800x900 mm**
- **Height – 1450 mm**
- **Weight – 180 kg**
- **Table speed – 7 r.p.m.**

The tyre-changer is equipped with

- manometer,
- lubricator,
- lever.

### **INSTALLATION.**

1. The machine should be installed on a hard flat surface.
2. Connect the power cable to 3 x 400V/50Hz mains socket.

### **ATTENTION:**

The tyre-changer has four-core power cable. Green-Yellow wire is protective wire and is connected with machine body. The rest wires are phase wires.

The direction of motor rotation should be checked after connection to electric power supply: depress the pedal 18 (fig.4), turntable should rotate clockwise. If the turntable rotate counterclockwise two phase wires should be interchanged.

3. Connect compressed air supply hose to the air supply terminal (pos. 1 fig. 1). Use pneumatic hose for working pressure min. 1MPa and of internal diameter 8 mm.

Check the oil in lubricator (pos. 3 fig.1). Depress pedal 16 (fig.4) and check whether clamps are moving.

**ATTENTION:**

- the oil in lubricator (pos.3 fig.1) should be replenished regularly,
- to replenish oil in lubricator unscrew carefully the transparent container and fill it with the oil,
- use the mineral oil free of water and acids, of viscosity 2-4 Engler degree (in temperature of 50°C
- hydraulic oil HL32 is recommended

**6. CONTROLLING ELEMENTS.**

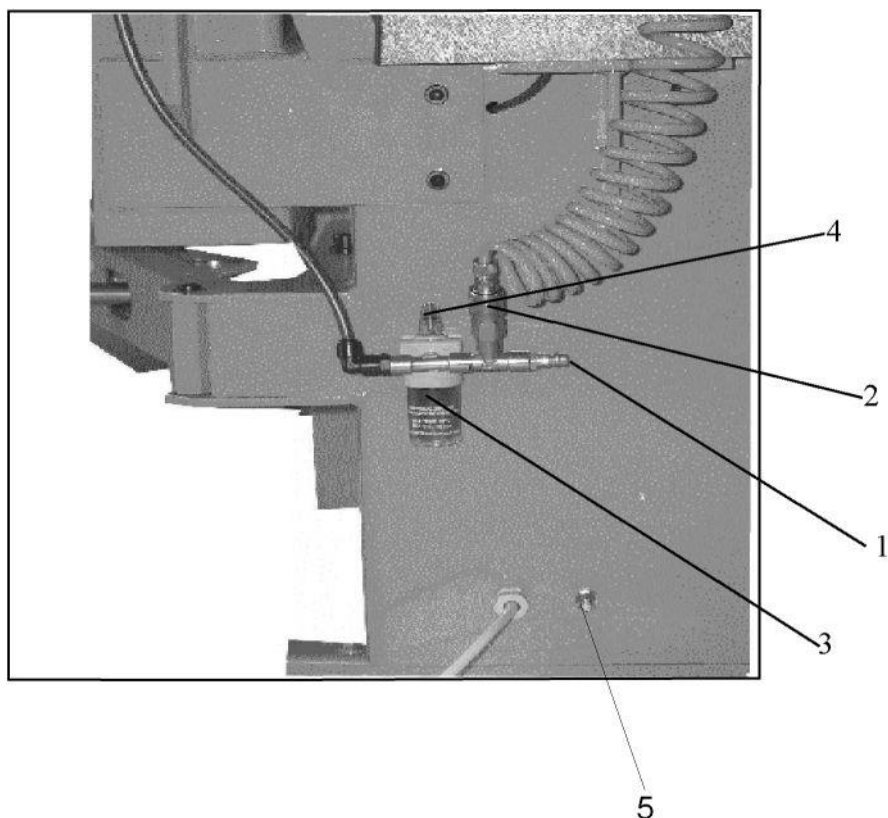

**FIG.1. Connections.**

**1 - supply terminal, 2 - pumping terminal, 3 - compressed air lubricator, 4 – lubricating intensity regulator, 5 – additional protective electric clamp.**



The main parts of tyre-changer are presented on figures 2-5.

**Fig.2. Main tyre-changer parts:**

**5 – control pedals**

**7 - table**

**8 – table jaws**

**9 - column**

**10 – head slide**

**11 – head arm**

**12 – bead breaker**

**13 – tyre inflation gun**

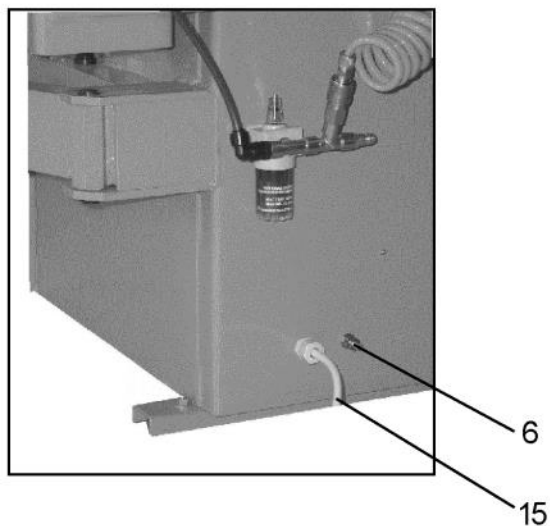
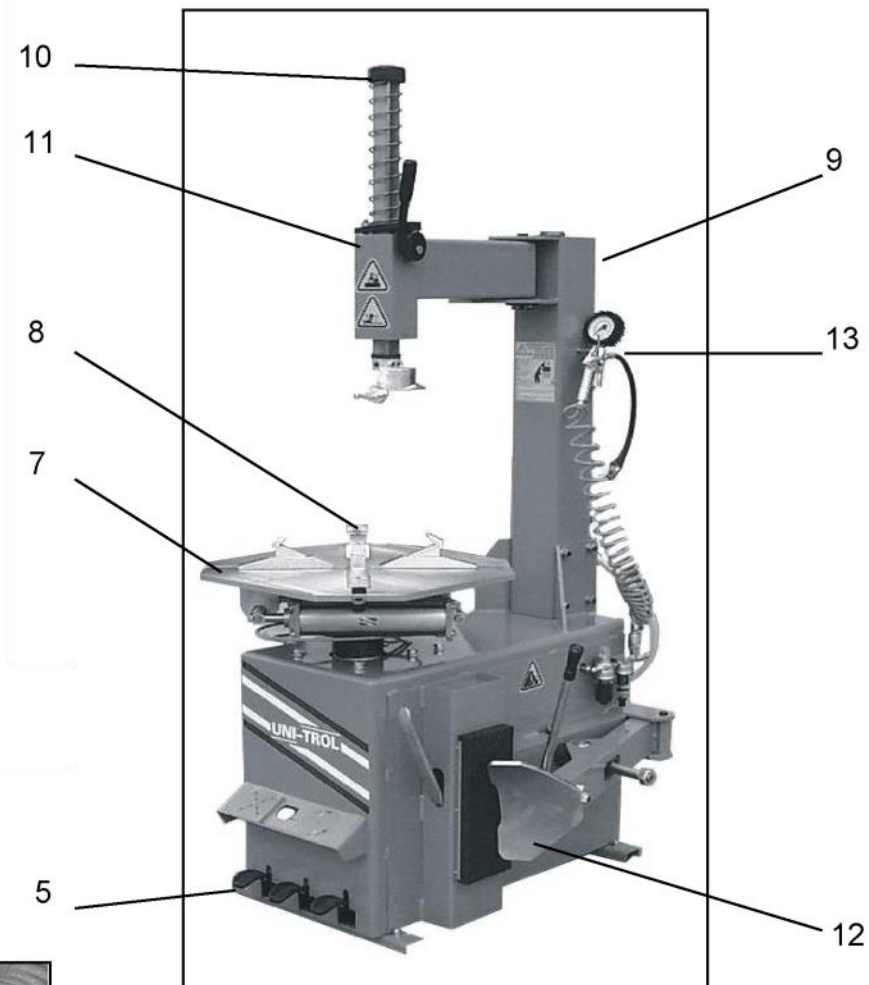

**Fig.3. Rear side view:**

**6 – additional protective terminal**

**15 – power supply cable**

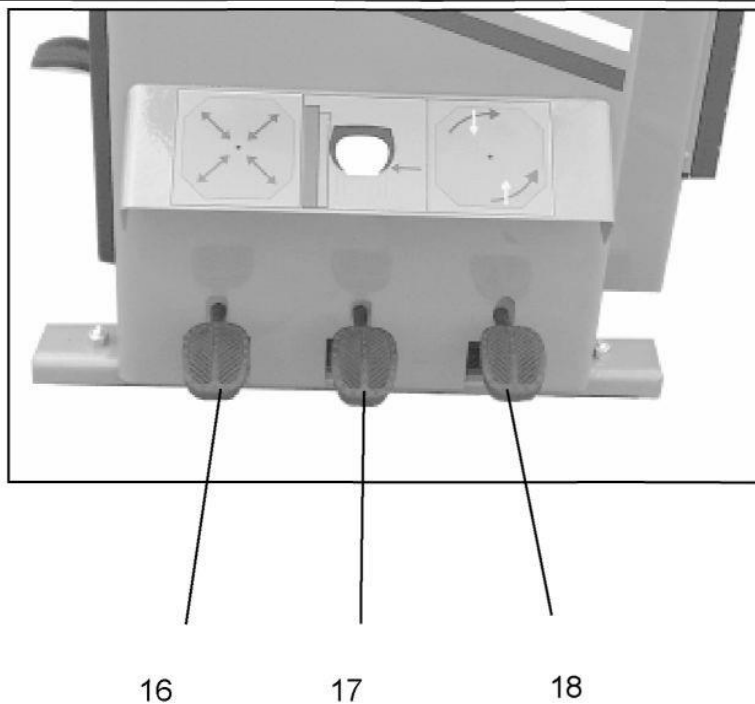

**Fig. 4. Control pedals:**

**16 – Wheel clamping pedal** controls inward and outward movement of table jaws.

It has three working positions:

- 1- Top position – jaws closed towards table center
- 2- Central position – outward jaws movement to any distance

How to operate the pedal in center position:

- depress pedal carefully until snap is heard;
  - release the pedal to be locked in central position;
  - next depress will move jaws outwards, next release will stop the jaws. Depress the pedal carefully to avoid its switch to bottom position.
- 3- Lower position – the jaws are fully drawn apart. Next depress will move it to the top position (close the jaws).

**17 – Bead Breaker Pedal** has two working positions:

- 1– Top (initial) – Bead Breaker switched off
- 2– Depress the pedal to switch Bead Breaker on. Release the pedal to switch the Break Breaker off.

**18 – Table Rotation Pedal** has three working positions.

- 1- Middle (initial) position – table drive is switchrd off
- 2- Depress the pedal to rotate the table clockwise (working rotation). Release the pedal to switch the rotation off
- 3- Lift the pedal (with foot) to rotate the table counterclockwise (emergency rotation). Release the pedal to switch the rotation off

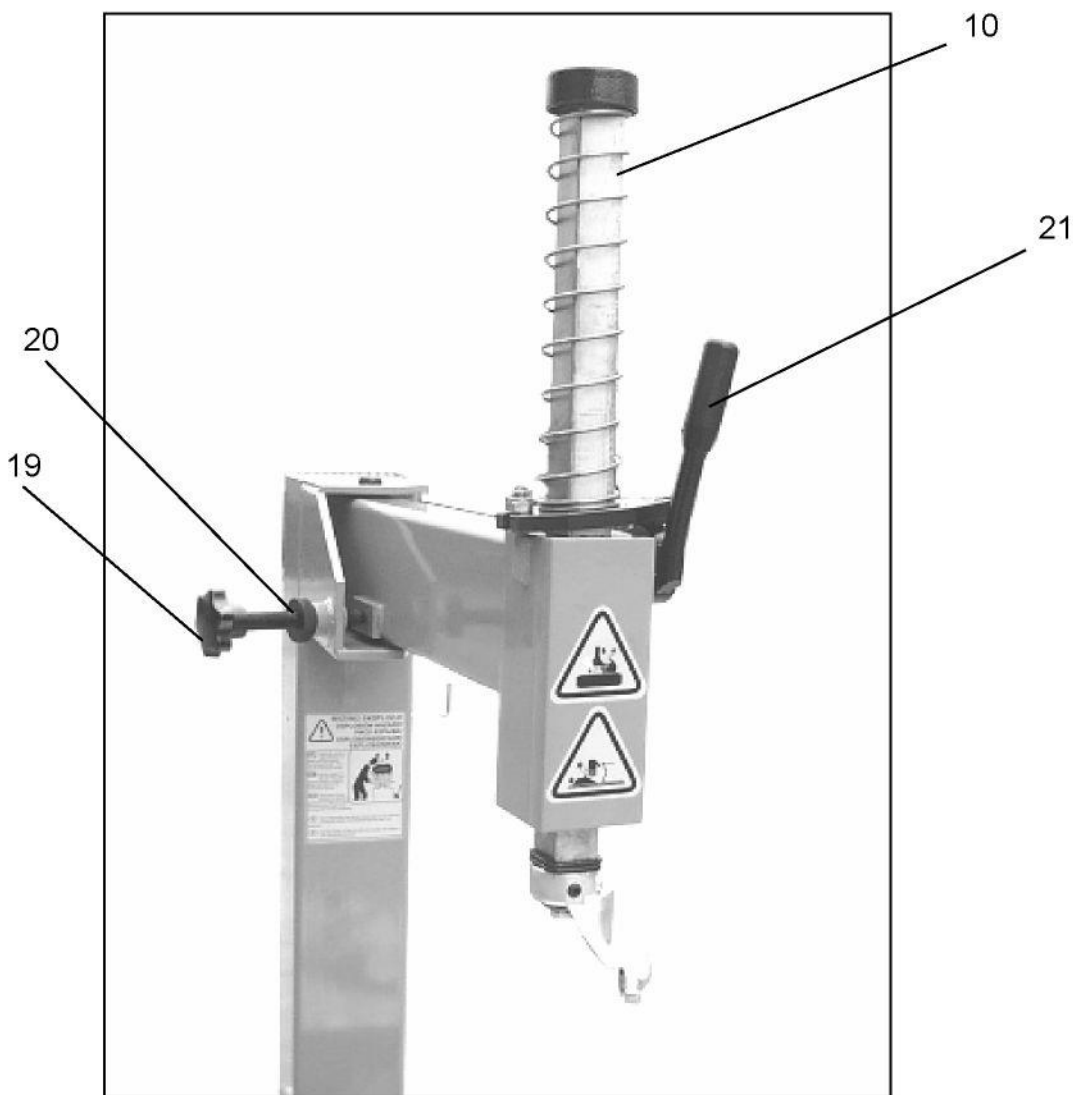

**Fig. 5. Working Head.**

**10 – head slide, 19 – arm position adjustment knob, 20 – locking nut, 21 – head slide locking lever.**

**19 – arm position adjustment knob** adjusts the clearance between the mounting head and the rim.

**20 – locking nut** locks adjustment knob in certain position

**21 – head slide locking lever.** Approach the mounting head to the rim by pressing the head slide (10). Set the lever upwards and block the slide in working position.

## **7. TYRE DEMOUNTING.**

Turn power and air supply of the machine on.

Pull away by hand bead breaker lever 22. Place wheel between bead breaker arm and rubber pad on machine side and bring arm against tyre directly next to wheel rim edge.

**ATTENTION: ARM MUST NOT REST AGAINST RIM !**

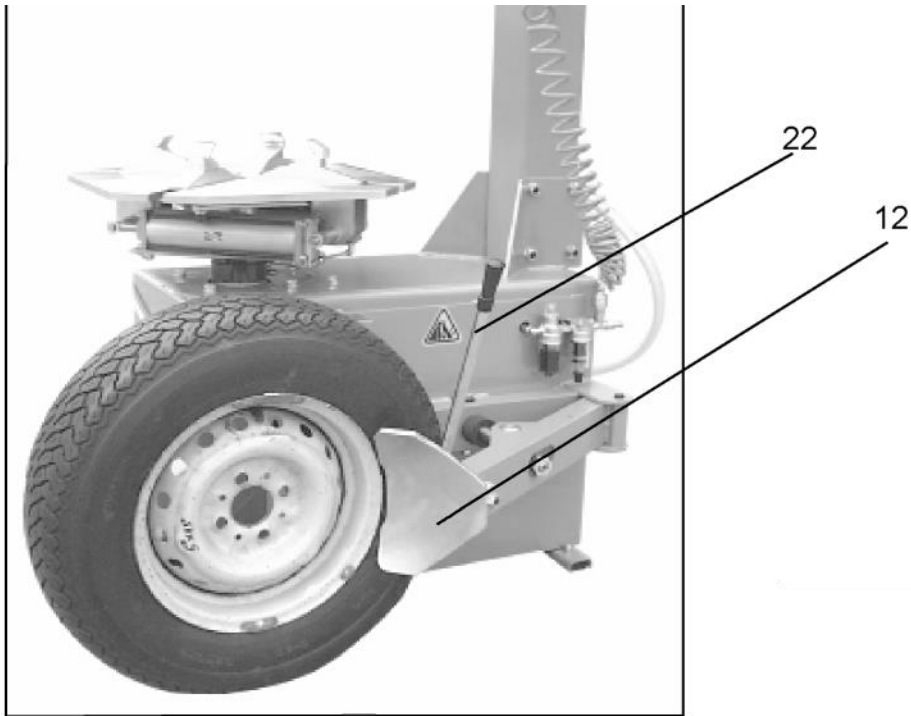

**Fig. 6. Tyre demounting.**

**12 – bead breaker arm**

**22 – bead breaker lever**

Holding bead breaker arm in appropriate position, depress bead breaker pedal 17 and hold it down until the tyre is separating from rim. Repeat if necessary this operation at several points of the wheel circumference.

Next turn the wheel over and, the same way, separate the tyre from the rim on the other side.

Move head arm 11 left to take it clear of the wheel.

Open table jaws by pedal 16 (pedal in central or bottom position). Place wheel on machine table so that the tire rests on the jaws and shift 16 to top position.

Check whether jaw hitches grip rim edge securely.

Grip with left hand the top of slide 10 and with right hand slide locking lever 21 by turning the arm to the left, bring the foot to contact with rim edge, as shown in Fig.8. Then, lift the foot slightly above rim edge to obtain proper vertical clearance and shift lever 21 upwards-the slide will lock.

By means of knob 19 set horizontal clearance between wheel and working head and lock the knob with nut 20.

Press bead tyre opposite the foot into wheel rim recess. Rest tyre lever on foot support 23 and pull bead tyre onto bulb 24-as shown in Figs 9 and 10.

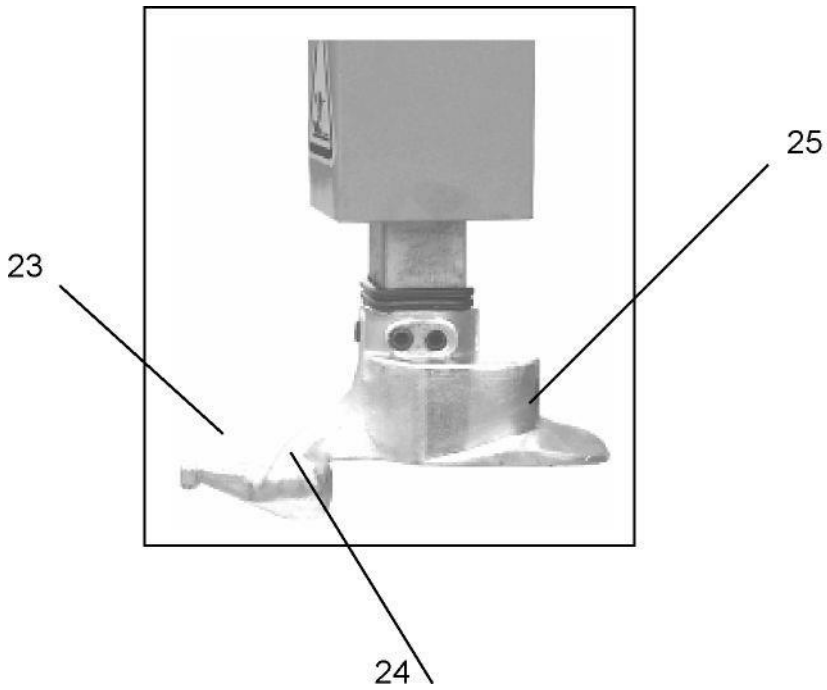

**Fig.7. Working head.**

**23 – support**

**24 – bulb**

**25 – slide**



**Fig. 8. Head in working position.**



**Fig. 9. Pulling bead tyre edge onto bulb.**



**Fig. 10. Tyre demounting.**

Rotate machine table clockwise depressing pedal 18 until the lower tyre edge fits in then wheel rim. In the case of problems during tyre removal (e.g .jamming) release pedal and move it with your foot up. Then the table will rotate counterclockwise and it will release the jammed tyre.

The lower tyre edge is removed from the wheel rim without unclamping the wheel or altering the working head position of the. It is enough to remove the tube, push the bead tyre, opposite the working head, into wheel rim recess and repeat tyre demounting operation, as described above.

Move lever 21 downwards to release the slide. The working head will lift up. Move arm 21 by hand to the right so that it doesn't interfere with operations being done on the table. Put tyre away. Open table jaws with pedal 16 and remove rim from the machine.

## **8. TYRE MOUNTING.**

Move arm 11 to the right.

Open table jaws by pedal 16( pedal in central position or bottom position). Place wheel rim on machine table and shift pedal 16 to top position. Check whether jaws hitches grip rim edge securely.

Place tyre on rim. Grip, with your left hand, the top of slide10 and , with your right hand , slide locking lever 21.

Moving the slide by an appropriate distance and turning the arm to the left rest the working head against rim edge, as shown in Fig.8.Then, lift the working head slightly above rim edge, in order to obtain proper vertical clearance and shift lever 21 upwards. The slide will be locked.

By means of knob 19, set horizontal clearance between rim and working head and lock knob with nut 20.

Press bottom tyre edge, opposite the working head, into wheel rim recess. Place the opposite tyre edge on the working head slide 25 press under bulb 24 as shown in Fig.11.



**Fig. 11. Tyre mounting.**

Depressing pedal 18 turn the table clockwise until the lower tyre edge will be placed on a rim. In case of the problem during the mounting (jam) release the pedal and lift it by foot. Table will turn counterclockwise and release jammed tyre. Put the tube.

Press top tyre edge which is in front of the working head into rim recess and put the rim on the tyre top edge the same way as for lower edge.

Pump the wheel by gun with manometer.

Move the arm 21 downward unblocking the slide. Working head will lift up.

Move arm 21 by hand to the right so that it doesn't interfere with operations being done on the table. Open the jaws by pedal 16 and remove the rim from the machine.

## **9. TYPICAL FAULTS AND REPAIRS.**

**1) After Tabel Rotation Pedal** has been depressed short circuit of motor supply cable ensued.

- Check the cable,
- Short circuit in the motor.

**2) Table Rotation Pedal** doesn't return to the initial position.

- Pedal spring is broken.
- Exchange the spring.

**3) Bead Breaker Pedal and Table Rotation Pedal** don't return to initial position.

- Pedal spring is broken.
- Exchange the spring,
- No oil in lubricator. Fill lubricator up with oil HL32.

**4) Air escapes near the bead breaker cylinder rim.**

- Exchange the gasket,
- Exchange the bead breaker cylinder.

**5) The table doesn't rotate.**

- Exchange the V-belt,
- Exchange transmission.

**6) The table doesn't rotate. The motor roars.**

- Check the cables connections in plug, socket, junction box.
- Exchange the motor.

**7) Jaws don't hold the wheel.**

- Exchange jaws.

**8) Table rotates with difficulties during tyre mounting and demounting.**

- Check and adjust the belt tension or exchange the belt.

**9) Manometer indicator don't return to position 0.**

- Exchange manometer.

## **WARNING**

The manual "SPARE PARTS" does not authorize the end-user for reparation unless they have been described in OPERATING MANUAL. The manual "SPARE PARTS" provide the end-user with information for helping the service staff to remove the fault.

## **10. WARRANTY.**

**All repairs and adjustments must be carried out only by manufacturer. Equipment repair by end-user results in loss of warranty.**

## **11. MAINTENANCE /SCRAPING.**

Maintenance must be carried out ONLY BY SKILLED PERSONNEL WHO ARE VERY FAMILIAR WITH THE TYRE-CHANGER.

When performing maintenance on the tyre-changer, follow all the necessary precautions to PREVENT THE TYRE-CHANGER FROM BEING STARTED ACCIDENTALLY: the main switch on the control box must be in POSITION "0".

The compressed air generator must be off and disconnected. Always remember the main possible risks and safety instructions seen in chapter 4 "SAFETY".

Tyre-changer table is driven by electric motor and spindle gear which is lubricated by Shell OMALA oil 680. After 4.000 working hours the gear must be cleaned and oil exchanged.

**IMPORTANT: To ensure proper maintenance:**

- Only use original spare parts and tools that are suitable for the job and in good condition;**
- Follow the maintenance schedule indicated in the manual; these frequencies are indicative and must always be considered as general rules to be respected.**

Good preventive maintenance requires constant attention and continuous

supervision on the machine. Quickly find the cause of any abnormalities such as excessive noise, overheating, leaking fluids, etc.

PERIODIC MAINTENANCE

OPERATION FREQUENCY.

To keep the tyre-changer working at full efficiency, follow the indicated maintenance schedule.

The manufacturer will not be responsible and will not honour the warranty as a result of non-compliance with the instructions indicated above.

**ALL MAINTENANCE OPERATIONS MUST BE PERFORMED WITH THE MAIN CONTROL PANEL SWITCHED OFF AND THE COMPRESS AIR GENERATOR SWITCHED OFF AND DISCONNECTED.**

Before scraping remove all electric, electronic and plastic elements and scrap machine as a steel scrap.



# **Spare-parts catalogue for tyre-changer OLA**

## Tyre-changer OLA

1.	Column	01.01.00
2.	Swinging device	01.02.00
3.	Working arm	02.01.00
4.	Locker unit	02.02.00
5.	Working head unit	02.05.00
6.	Vertical slieder	02.00.01
7.	Clamp	02.00.02
8.	Protection	02.00.04
9.	Table	03.00.00
10.	Driving unit	04.00.00
11.	Pedals unit	05.00.00
12.	Body	06.00.00
13.	Bead breaker cylinder	07.00.00
14.	Bead breaker unit	09.00.00
15.	Silencer	10.00.00
16.	Gasket o-ring 32x5	03.07.132
17.	Spring S 788	06.01.066

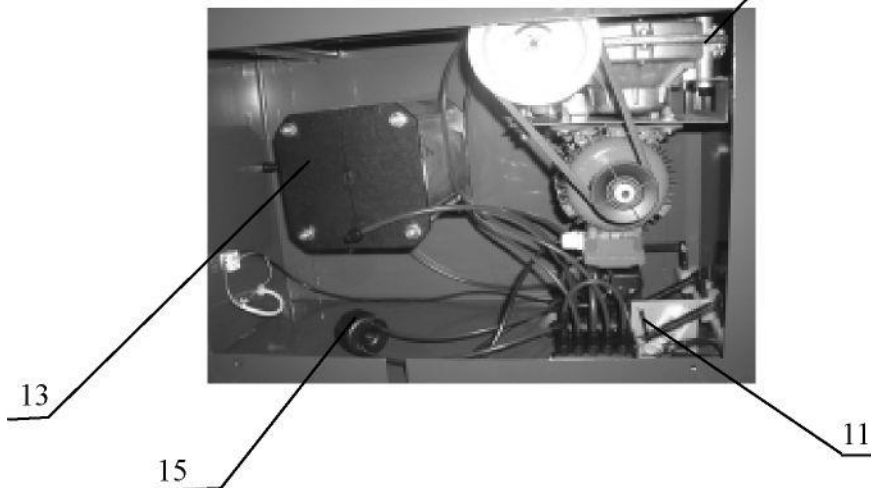
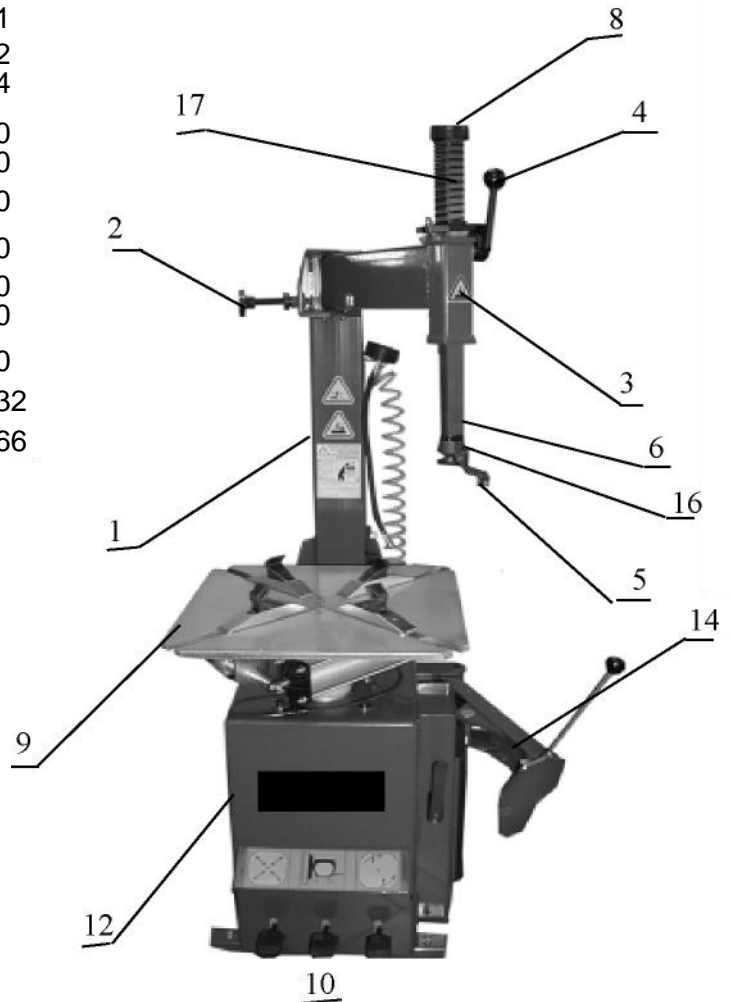

Working head unit 02.05.00

- |    |              |          |
|----|--------------|----------|
| 1. | Working head | 02.05.04 |
| 2. | Roller axle  | 02.05.02 |
| 3. | Head roller  | 02.05.03 |

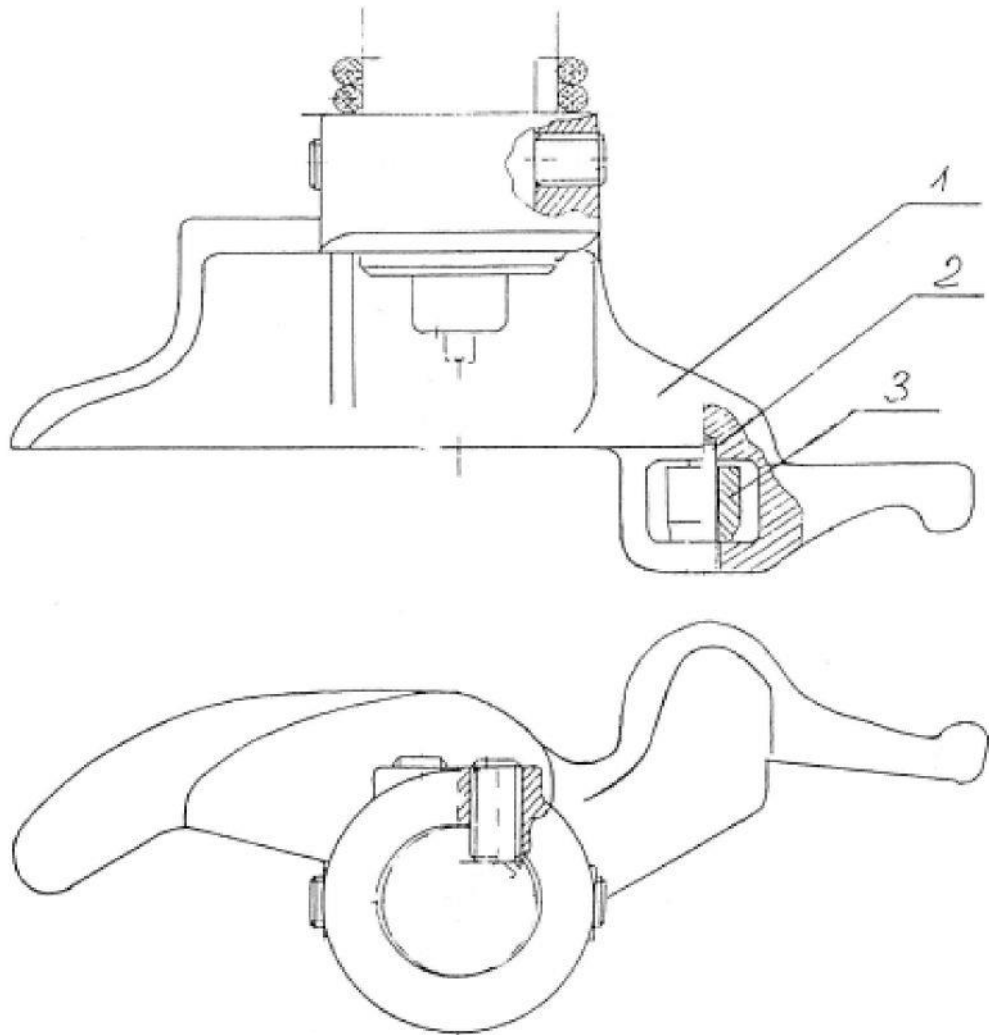

Stół kompletny 03.00.00

- |     |   |           |
|-----|---|-----------|
| 1.  | Table                                     | 03.03.00  |
| 2.  | Turntable                                 | 03.02.00  |
| 3.  | Spreader                                  | 03.03.00  |
| 4.  | Hanger                                    | 03.04.00  |
| 5.  | Table cylinder                            | 03.05.00  |
| 6.  | Table slider                              | 03.00.15  |
| 7.  | Clamp                                     | 06.04.027 |
| 8.  | Angle connector 2020 - 1/8"               | 07.06.513 |
| 9.  | Tee 6400-6-1/8"                           | 07.06.505 |
| 10. | Connector 6500-6-1/8"                     | 07.06.509 |
| 11. | Straight connector $\varnothing$ 6 - 1/8" | 07.06.502 |
| 12. | Tee $\varnothing$ 6                       | 07.06.401 |
| 13. | Angle connector $\varnothing$ 6           | 07.06.406 |
| 14. | Tube $\varnothing$ 6 - 1/8"               | 07.06.601 |
| 15. | Hose $\varnothing$ 6x4                    | 07.05.003 |

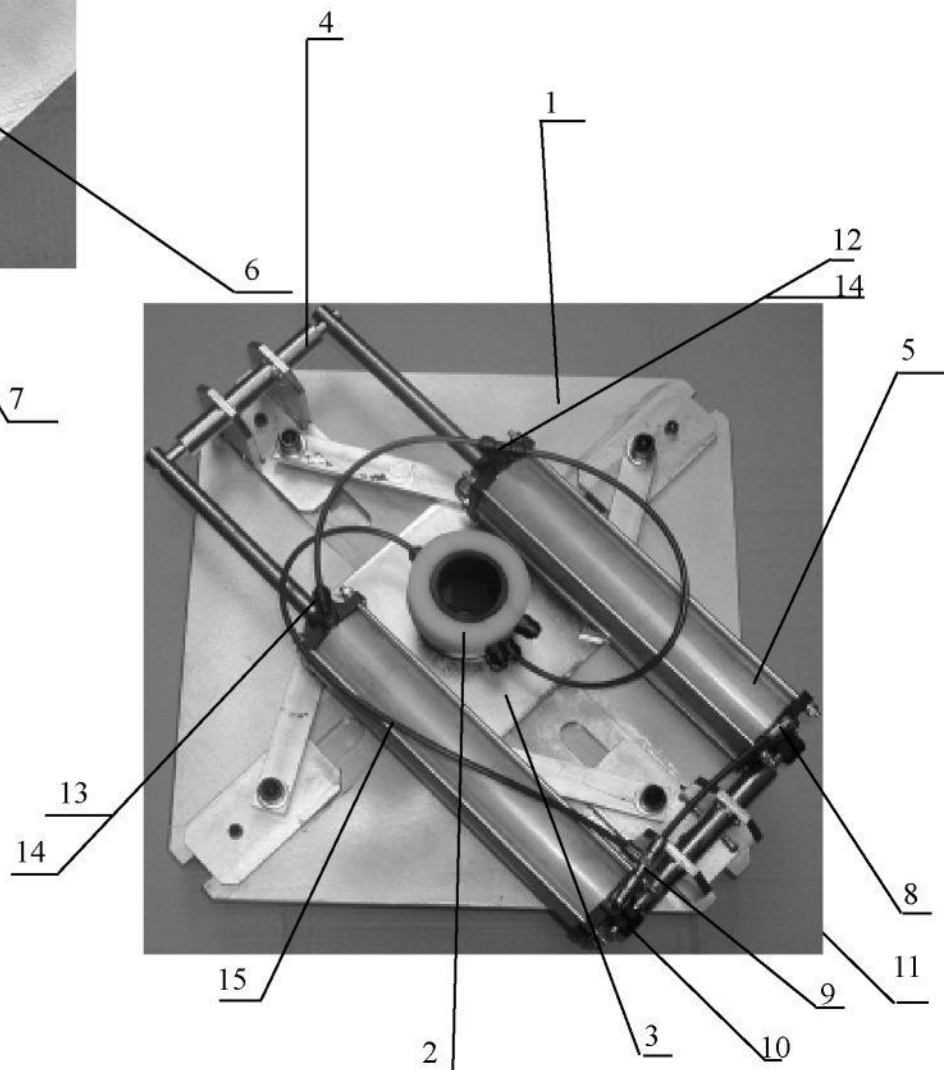
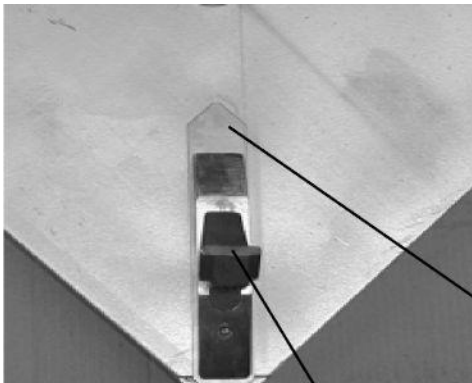

Turntable 03.02.00

- |    |                                  |           |
|----|----------------------------------|-----------|
| 1. | Movable sleeve                   | 03.02.01  |
| 2. | Immovable sleeve                 | 03.02.02  |
| 3. | Gasket o-ring $\varnothing$ 65x2 | 03.07.151 |

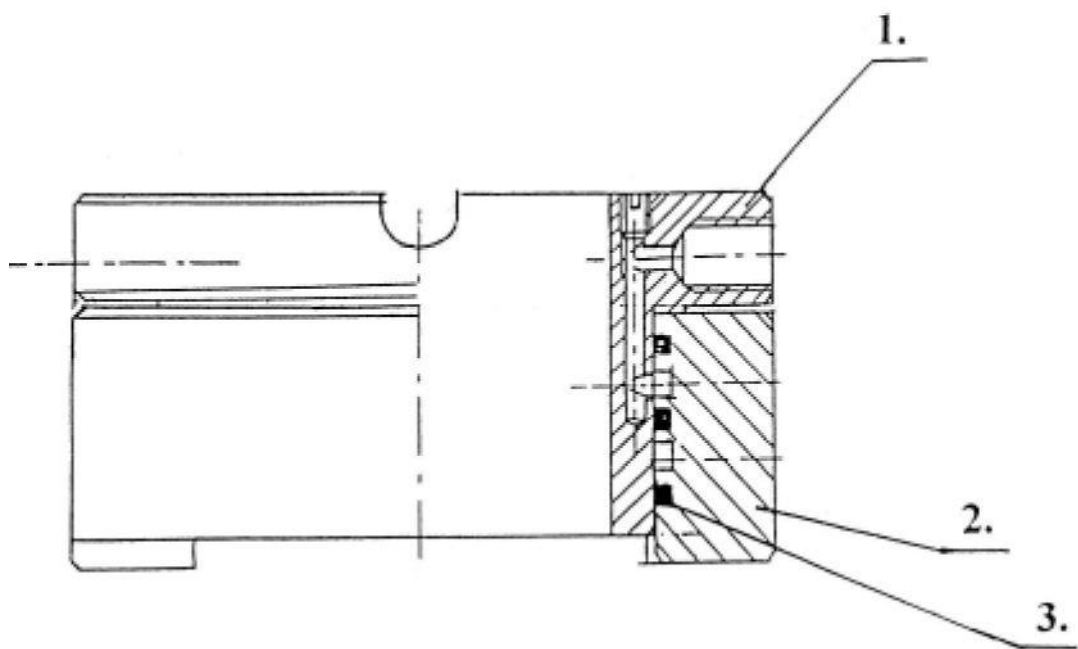

### Table cylinder 03.05.00

1.	Piston rod	03.05.01
2.	Cylinder	03.05.08
3.	Sleeve 1820 BS	03.08.901
4.	Upper cover	06.04.024
5.	Lower cover	06.04.025
6.	Piston	06.04.023
7.	Gasket U2 18x30x8	03.07.602
8.	Gasket o-ring $\varnothing 2$	03.07.109
9.	Gasket o-ring $\varnothing 60 \times 2$	03.07.161
10.	Gasket o-ring $\varnothing 57 \times 3,5$	03.07.156

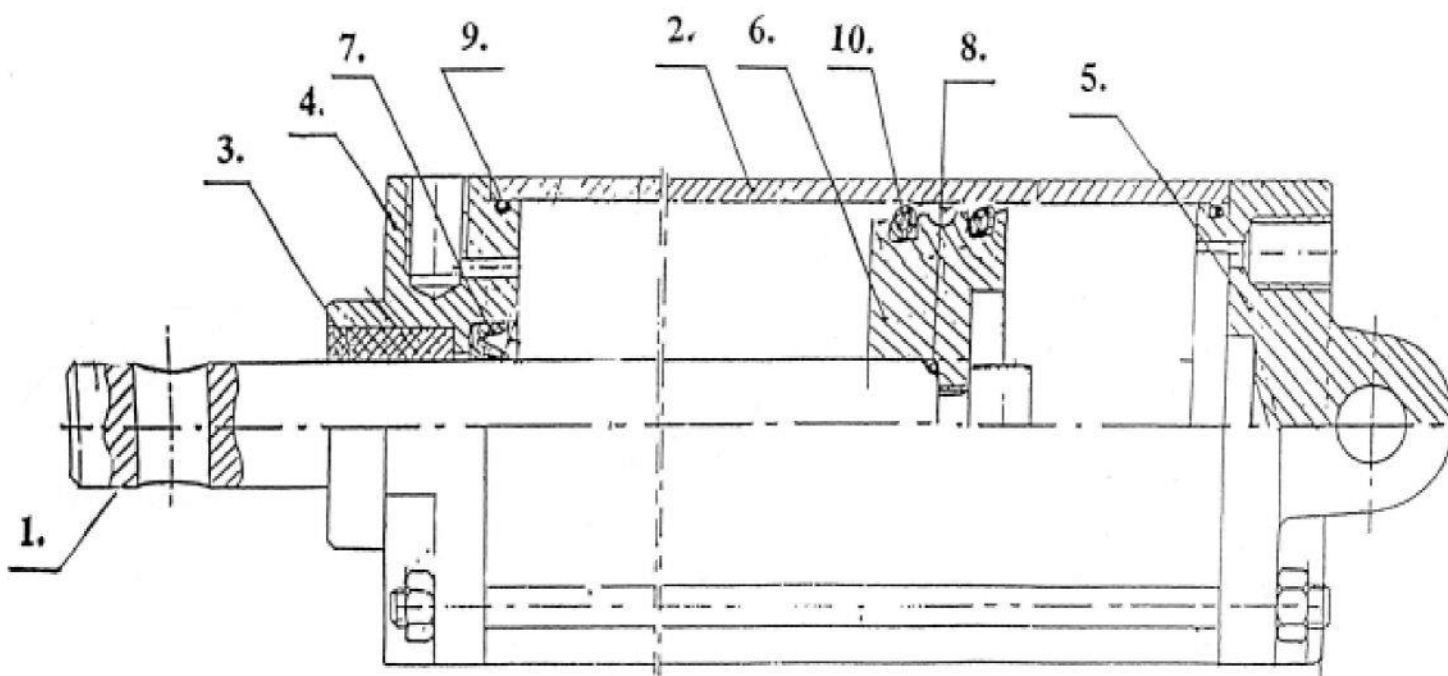

## Driving unit 04.00.00

- |    |                          |               |
|----|--------------------------|---------------|
| 1. | Reducer                  | 04.01.00      |
| 2. | Pulley                   | 06.04.020     |
| 3. | Motor pulley             | 06.04026      |
| 4. | Electric motor SH80-4B   | 05.06.003 - 3 |
|    | Electric motor SEMh80-4C | 05.06.006 - 1 |
| 5. | Pasek klinowy HA-710     | 05.08.304     |

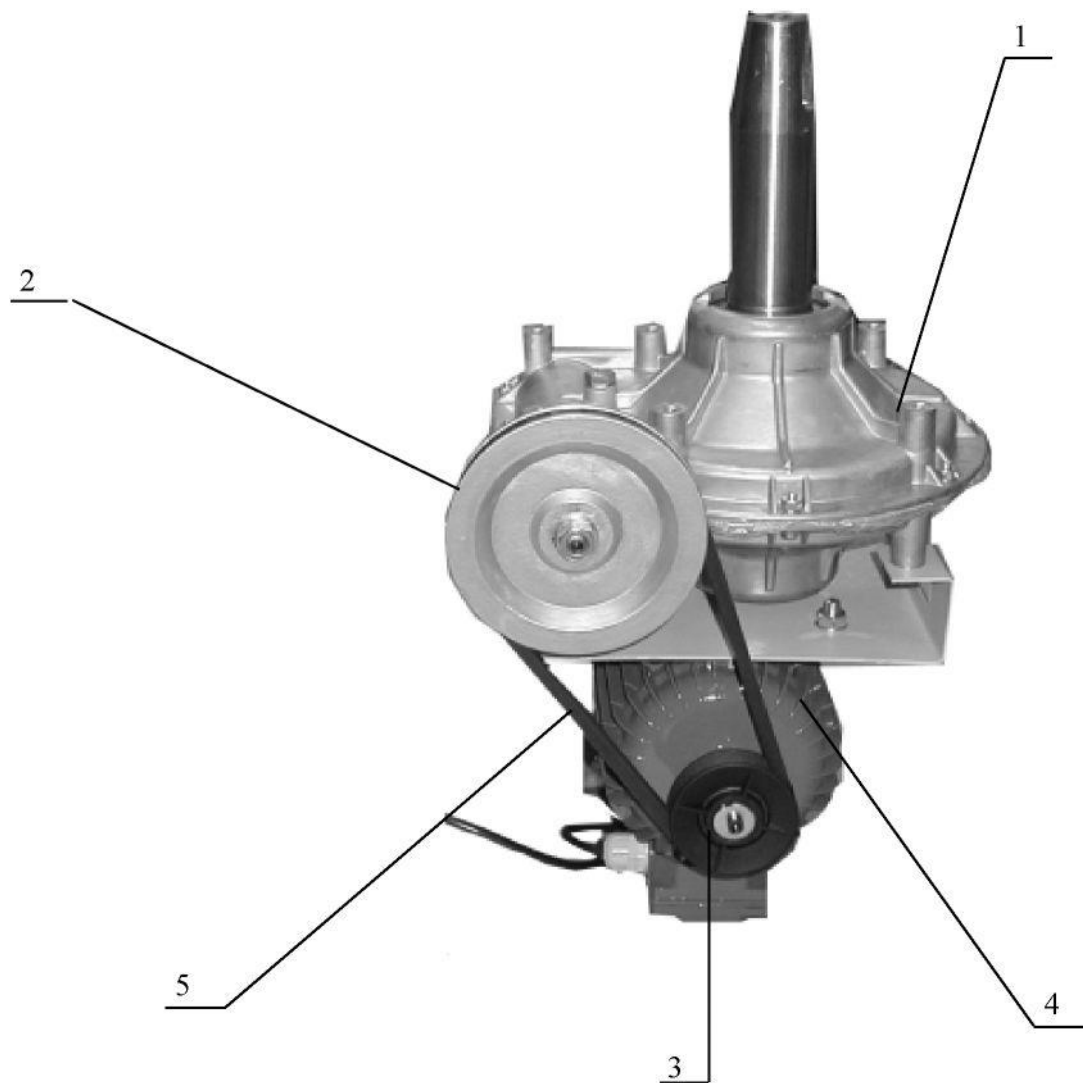

## Reducer 04.01.00

- |    |                     |           |
|----|---------------------|-----------|
| 1. | Worm wheel unit     | 04.01.00A |
| 2. | Worm screw          | 04.01.01  |
| 3. | Reducer body        | 04.01.06  |
| 4. | Bearing 6010        | 03.08.010 |
| 5. | Bearing 6208        | 03.08.208 |
| 6. | Bearing 30204       | 03.08.401 |
| 7. | Gasket ring 20x40x7 | 03.07.401 |

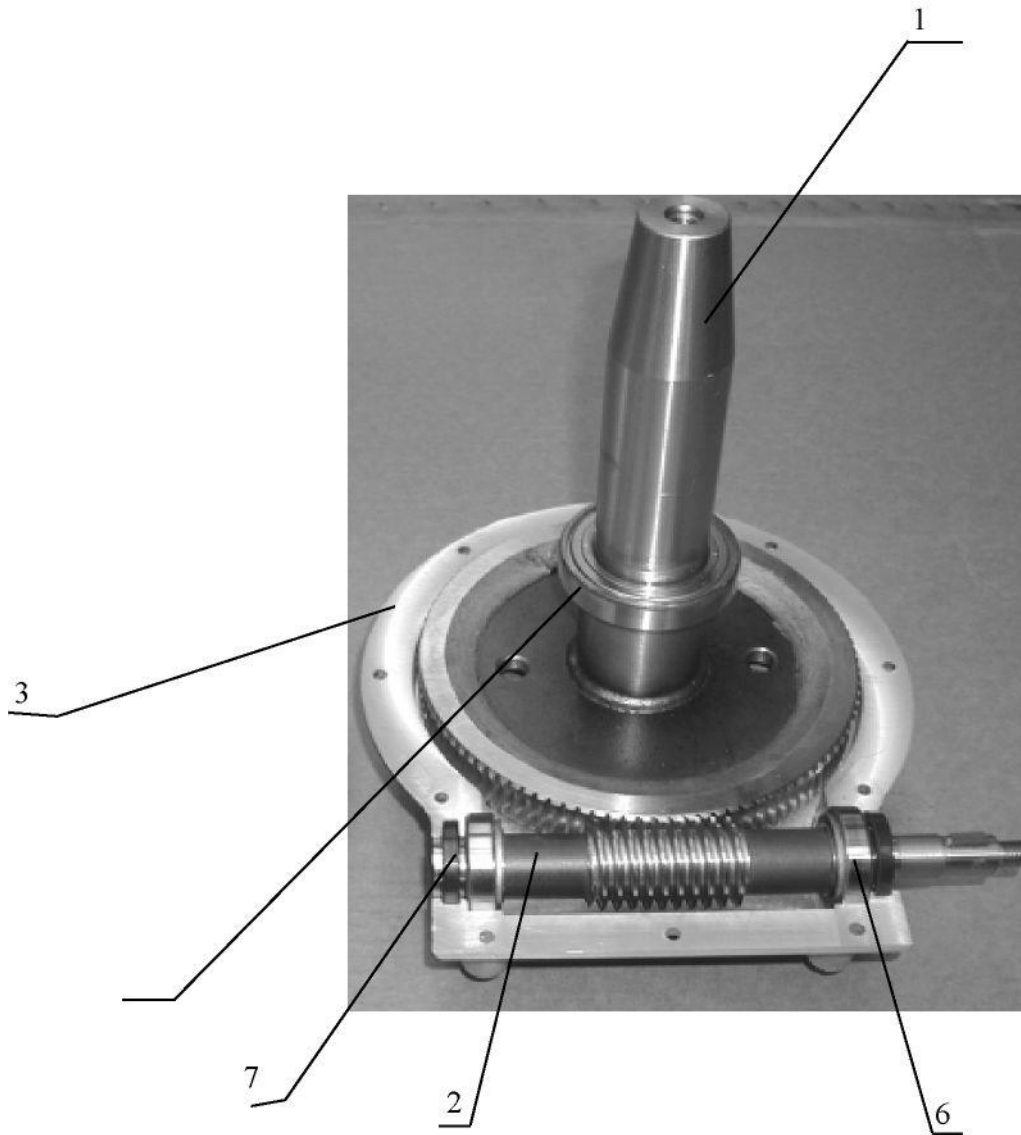

Bearing № 5 is on reducer spindle from invisible side of the worm wheel.



Pedals unit 05.00.00

Base unit	05.01.00
Distributor unit	05.02.00
Pedal unit I	05.03.00
Pedal unit II	05.04.00
Pedal unit III	05.05.00
Pawl	06.05.001
Spring R253	06.01.063
Spring .1145	06.01.064
Spring 13-5	06.01.065
Switch ŁK15	05.05.003 -3-fazowy
Switch ŁK15	05.05.006 -1-fazowy
Tee $\varnothing$ 6	07.06.401
Tee $\varnothing$ 8	07.06.403
Straight connector $\varnothing$ 6 - 1/8"	07.06.502
Straight connector $\varnothing$ 8 - 1/8"	07.06.503
Tube $\varnothing$ 6 - 1/8"	07.06.601
Tube $\varnothing$ 8 - 1/8"	07.06.603

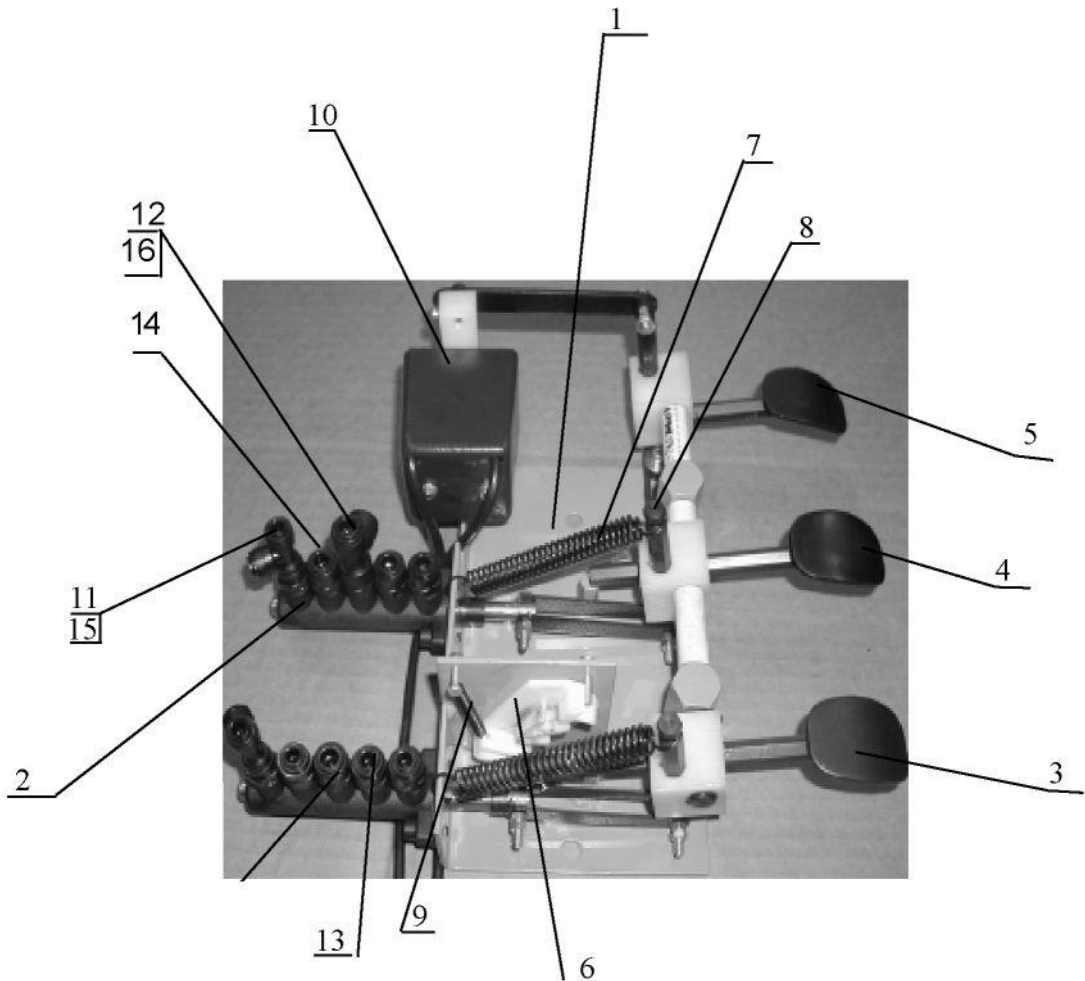

Distributor unit 05.02.00

1	Slider	05.02.01
2.	Front sleeve	05.02.02
3.	Middle sleeve	05.02.03
4.	Rear sleeve	05.02.05
5.	Distributor	06.05.005
6.	Gasket o-ring 9,7x3,3	03.07.111

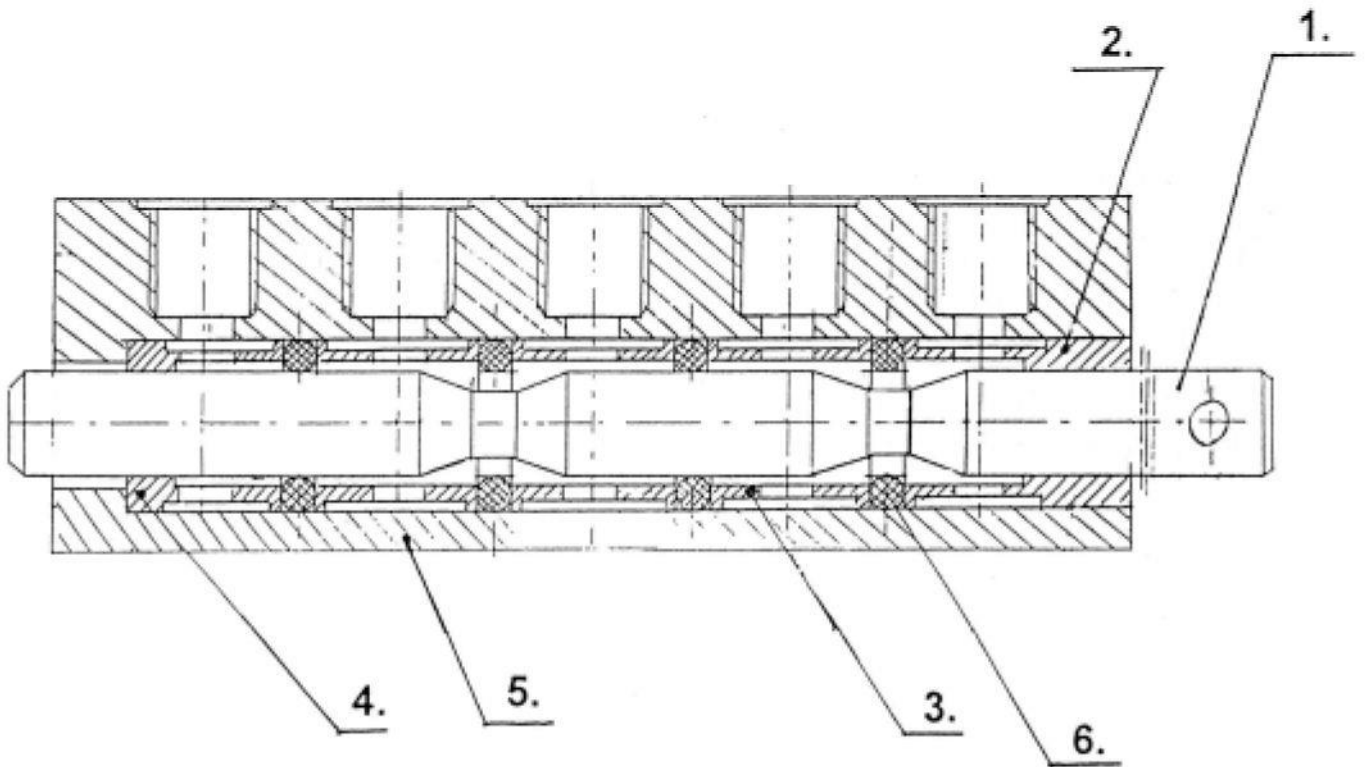

# Bead breaker cylinder 07.00.00

- |     |                                |           |
|-----|--------------------------------|-----------|
| 1.  | Front cover                    | 07.01.00  |
| 2.  | Rear cover                     | 07.00.17  |
| 3.  | Cylinder                       | 07.00.18  |
| 4.  | Piston                         | 07.00.19  |
| 5.  | Piston rod                     | 07.00.20  |
| 6.  | Self lubricating sleeve 2230BS | 03.08.902 |
| 7.  | Gasket o-ring 180x5            | 03.07.185 |
| 8.  | Gasket o-ring 180x3            | 03.07.175 |
| 9.  | Gasket o-ring 18x3             | 03.07.117 |
| 10. | Gasket U1 - 22x5               | 03.07.603 |

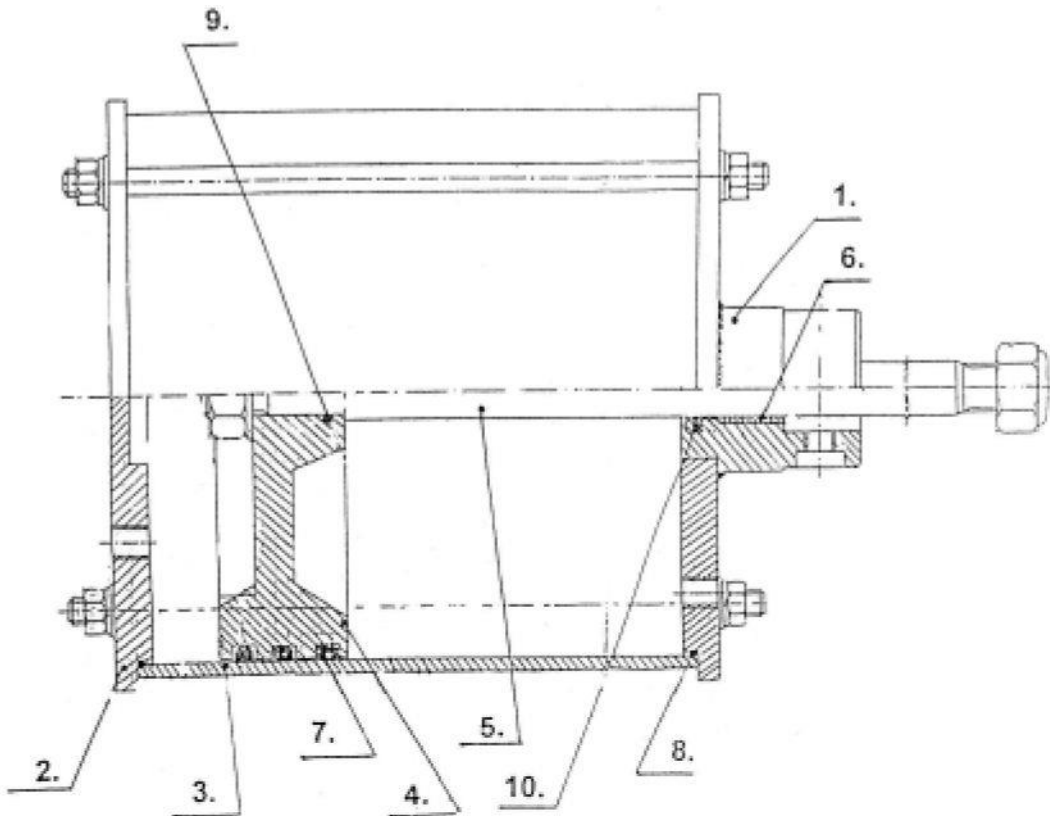

# UNI - TROL

UNI - TROL Co. Ltd

MANUFACTURING PLANT & STORE

ul. Estrady 56,01 - 932 Warsaw

POLAND

<http://www.unitrol.com.pl>

tel ./fax (+48 22) 8179422

WHEEL BALANCING MACHINES

TYRE CHANGERS

EQUIPMENTS FOR TYRESHOPS

Statistic number: 008132994

Tax number : 527 - 020 - 52 - 46

Declaration of Conformity CE  
according to directives: 98/37/CE i 89/336/CEE

We: **Uni-trol Sp. z o. o.**  
**Ul. Estrady 56**  
**01-932 Warszawa**  
**Polska**

Declare under our sole responsibility that product

## Tyre-changer OLA

Which is a subject of this declaration complies with the following law regulations :

- dyrektywa 98/37/CE ( equipment safety );
- dyrektywa 89/336/CEE And following modifications ( electro-magnetic compatibility

To verify the conformity with law regulations the following norms and documents have been consulted :

- PN-EN 292- 1 /2000 Machinery - safety – General terms of planning - Basic terms, methodology - Part 1;
- PN-EN 292-2/2000 Machinery - safety – General terms of planning - Basic terms, methodology - Part 2;
- PN - EN 50081 - 1 /1996 Electro-magnetic Compatibility - Emission general requirements – Living, commercial and industrial environment - Part 1;
- PN - EN 50081 - 2 /1996 Electro-magnetic Compatibility - Emission general requirements – Living, commercial and industrial environment - Part 2;
- PN - EN 50082 - 1 /1999 Electro-magnetic compatibility – Immunity to disturbance requirements - Living, commercial and industrial environment - Part 1;
- PN - EN 50082 - 2 /1997 Electro-magnetic compatibility – Immunity to disturbance requirements - Living, commercial and industrial environment - Part 2;
- PN - EN 294 /1994 Safety of machinery - Safety distance to prevent danger zones being reached by the upper limbs
- PN - EN 349 /1999 Machinery - Safety – Minimum gaps to avoid crushing of parts of the human body;
- PN-EN 60204-1/2001 Safety of machinery – Machinery electric equipment - Part 1: General requirements;
- PN-EN 61204/2001 Low voltage power suppliers – Safety characteristics and requirements;
- PN-EN 61293/2000 Marking of electrical equipment with ratings related to electrical supply – Safety requirements;
- 62/2002 Electrical components;
- PN-EN 983/1999 Safety of machinery Safety requirements for fluid power systems and their components - Pneumatic

This declaration is valid for all products manufactured according to technical documentation which is a part of this declaration.

Wiesław Roguski  
President  
Warsaw, 10.01.2003

.....  
**Signature**