

USE AND MAINTENANCE MANUAL

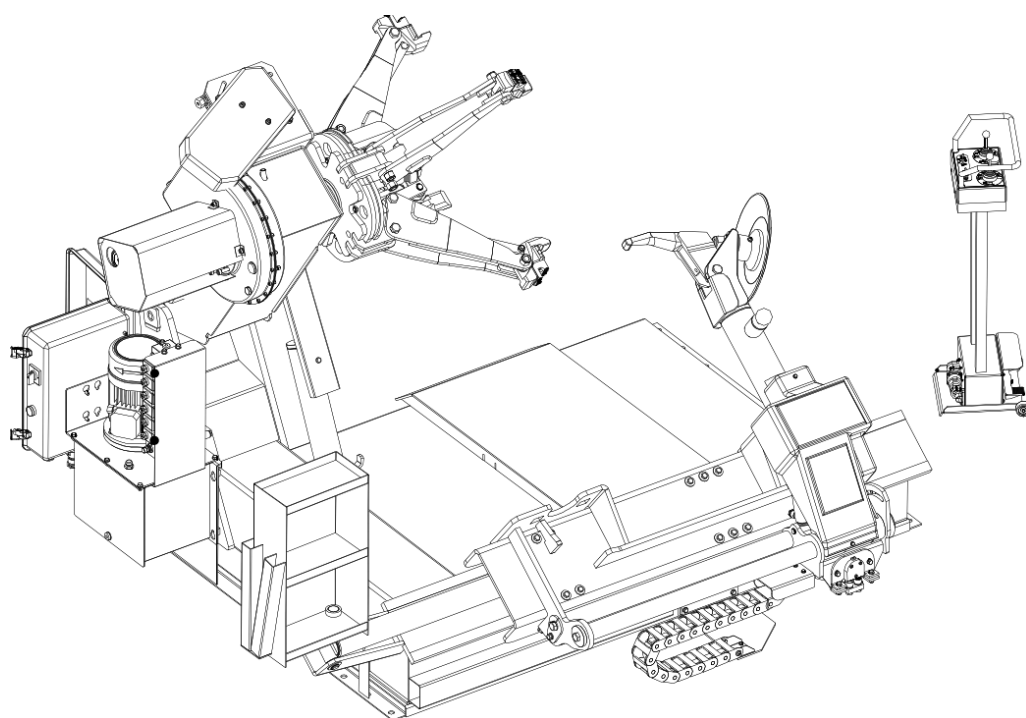

TRUCK TIRE CHANGER

MAXI-56



PRINTING CHARACTERS AND SYMBOLS

Throughout this manual, the following symbols and printing characters are used to facilitate reading:

	Indicates the operations which need proper care
	Indicates prohibition
	Indicates a possibility of danger for the operators
BOLD TYPE	Important information

CONTENTS

1	INTRODUCTION	4
	1.1 - INTRODUCTION	4
	1.2 MACHINE IDENTIFICATION DATA	4
	1.3 MANUAL KEEPING	4
2	GENERAL INFORMATION	5
	2.1 INTENDED USE	5
	2.2 GENERAL SAFETY PRECAUTIONS	5
	2.3 SAFETY DEVICES	5
	2.4 PRODUCT DESCRIPTION	6
	2.5 TECHNICAL SPECIFICATION	7
3	TRANSPORTATION, UNPACKING AND STORAGE	8
	3.1 TRANSPORTATION	8
	3.2 UNPACKING	8
	3.3 STORAGE	8
4	INSTALLATION	9
	4.1 INSTALLATION SPACE REQUIRED	9
	4.2 WORKPLACE REQUIRED	9
	4.3 FOUNDATION REQUIREMENT	10
	4.4 ELECTRIC CONNECTION	11
5	CONTROLS AND CHECKS	12
	5.1 CONTROLS DESCRIPTION	12
	5.2 CORRECT OPERATION CHECKS	13
6	OPERATION	15
	6.1 WORKING POSITION	15
	6.2 LOCKING THE WHEEL	15
	6.3 LIGHT-ALLOY RIM LOCKING	16
	6.4 TUBELESS AND SUPERSINGLE WHEELS	16
	6.5 TUBED WHEELS	21
	6.6 WHEELS WITH SPLIT RING	24
7	ORDINARY MAINTENANCE	28
8	TROUBLE SHOOTING	29
9	MOVING, STORING AND SCRAPPING	30
	9.1 MOVING THE MACHINE	30
	9.2 STORING	30
	9.3 SCRAPPING A MACHINE	30
10	OPTIONAL ACCESSORIES	31
11	HYDRAULIC SCHEME AND ELECTRIC DIAGRAM	32



CHAPTER 1 – INTRODUCTION

1.1 INTRODUCTION

Thank you for purchasing a product from the line of truck tire changers. The machine has been manufactured in accordance with the very best quality principles. Follow the simple instructions provided in this manual to ensure the correct operation and long life of the machine. Read the entire manual thoroughly and make sure you understand it.

1.2 MACHINE IDENTIFICATION DATA

A complete description of the “Tire Changer Model” and the “Serial number” will make it easier for our technical assistance to provide service and will facilitate delivery of any required spare parts. For clarity and convenience, we have inserted the data of your machine in the box below. If there is any discrepancy between the data provided in this manual and that shown on the name plate fixed to the wheel balancer, the latter should be taken as correct.

 www.unitrol.com.pl	Uni-trol Sp. z o.o. ul. Estrady 56, 01-932 Warszawa, Polska Zakład Produkcyjny i Salon Sprzedaży ☎ +22 8179422 📠 +22 8179422 w. 115 e-mail: office@unitrol.com.pl
Serial number : 00/20	Tire changer model MAXI-56
  EEE waste	Dane techniczne : <ul style="list-style-type: none">- średnica obręczy koła : od 14" do 56"- max. średnica koła : 2400 mm- max. szerokość koła : 1300 mm- max ciśnienie hydrauliczne : 130 bar- zasilanie elektryczne : 3-faz. 3x400 V / 50 Hz- moc silnika pompy : 2,2 kW/1390 obr./min.- moc silnika napędu : 1,3/1,8 kW-1340/2570 obr./min.- uśredniony poziom ciśnienia- akustycznego : L_{sr} = 70 dBA- wymiary zewnętrzne : 1700x2100x1540 mm- masa netto : 1048 kg
RoHS Compliant Directive 2002/95/EC	Zalecane oleje: - hydraulika – SHELL TELLUS OIL 42 - reduktor – SHELL OMALA 680 lub ich parametryczne odpowiedniki innych producentów
Wyrób polski	

1.3 MANUAL KEEPING

For a proper use of this manual, the following is recommended:

- Keep the manual near the lift, in an easily accessible place.
- Keep the manual in an area protected from the damp.
- Use this manual properly without damaging it.
- Any use of the machine made by operators who are not familiar with the instructions and procedures contained herein shall be forbidden.

This manual is an integral part of the manual: it shall be given to the new owner if and when the machine is resold.



The illustrations have been made out of prototypes pictures. It is therefore possible that some parts or components of standard production differ from those represented in the pictures.

TO THE READER

Every effort has been made to ensure that the information contained in this manual is correct, complete and up-to date. The manufacturer is not liable for any mistakes made when drawing up this manual and reserves the right to make any changes due the development of the product, at any time

CHAPTER 2 – GENERAL INFORMATION

2.1 INTENDED USE

- This tire changer has been designed and manufactured exclusively for removing and mounting truck, bus and commercial van tires from/onto rims from 14" to 56" and a maximum diameter of 2400mm.
- In particular **THE MANUFACTURER** cannot be held responsible for any damage caused through the use of this tire changer for purposes other than those specified in this manual, and therefore inappropriate, incorrect and unreasonable.

2.2 GENERAL SAFETY PRECAUTIONS

- The machine should only be used by duly authorized and trained personnel.
- It is forbidden to use the machine for straightening rims, breaking beads of still inflated or dirty tires, and turning, rasping, and cutting tires.
- Under no way should the machine be modified except for those modifications made explicitly by **THE MANUFACTURER**.
- Never remove the safety devices. Any work on the machine should only be carried out by specialist personnel.
- Any tampering or modification to the equipment carried out without the manufacturer's prior authorization will free him from all responsibility for damage caused directly or indirectly by the above actions.
- The tire changer comes complete with instruction and warning transfers which are designed to be long-lasting. If they should for any reason be damaged or destroyed, please ask immediately for replacements from the manufacturer.
- The machine operator should avoid wearing clothes with flapping edges. Make sure that unauthorized personnel do not approach the machine during the work cycle.

2.3 SAFETY DEVICES

The tire changer has a number of safety devices designed to guarantee the upmost safety:

- **Check valve on the spindle opening hydraulic line** (inside the swivel connector, see fig. B/1). This prevents the wheel from falling from the spindle if the hydraulic line is accidentally broken.
- **Pressure relief valve set at 130 bar \pm 10%** (see fig. B/2). This limits the pressure in the hydraulic line and ensures correct operation of the plant.
- **Pump motor overload cut-off** (inside the electric enclosure, see fig. B/3). This cuts if the motor overheats to prevent it from burning out.

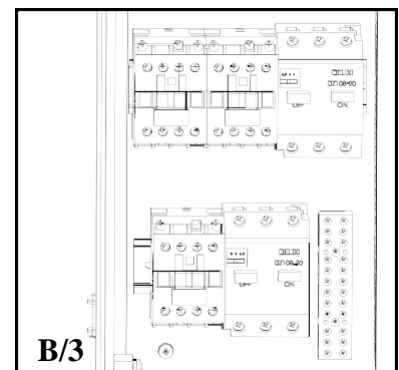
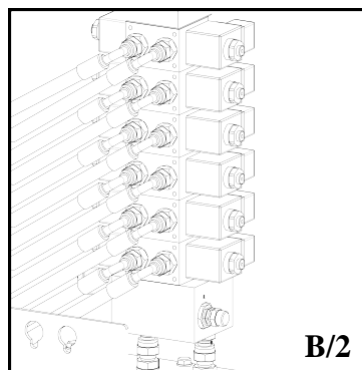
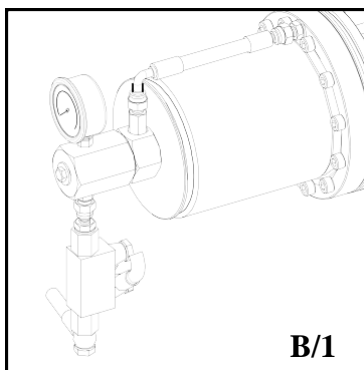

2.4 PRODUCT DESCRIPTION

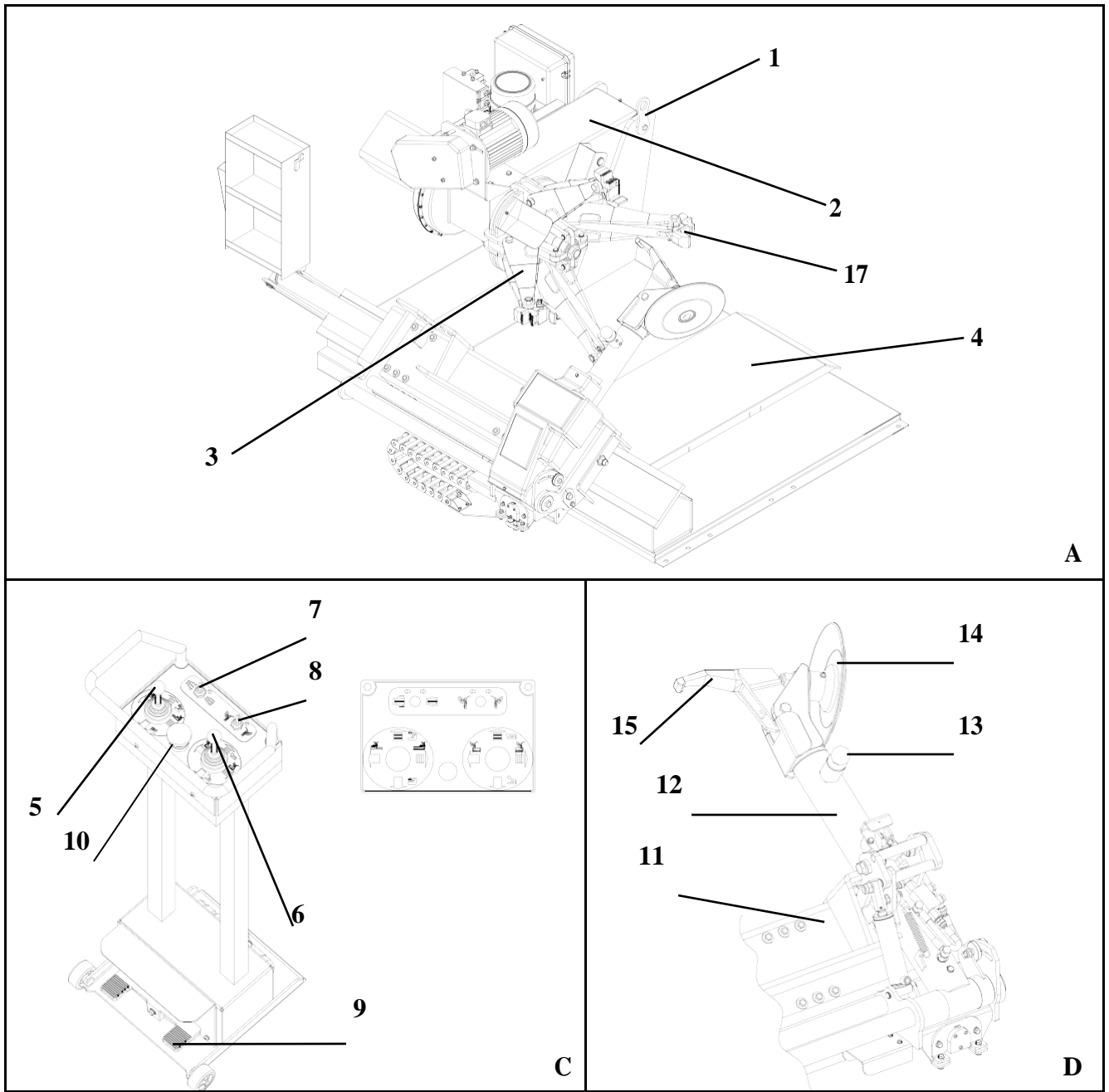

- | | |
|-------------------------------------|----------------------------|
| 1. Lifting bracket | 10. Emergency stop knob |
| 2. Self-centering chuck holding arm | 11. Tool carriage |
| 3. Self-centering chuck | 12. Tool holding arm |
| 4. Sliding table | 13. Tool arm position knob |
| 5. Joystick 1 | 14. Bead breaking disk |
| 6. Joystick 2 | 15. Tool |
| 7. Switch 1 | 16. Arm locking cylinder |
| 8. Switch 2 | 17. Jaw |
| 9. Pedal | |



During all operations, keep hands and other parts of the body as far as possible from any moving part of the machine. Necklaces, bracelets and too large cloths, can be dangerous for the operator.

2.5 TECHNICAL SPECIFICATION

Pump motor	2.2kw
Gear-box motor	2.6kw/3.2kw (3 ph double speed)
Handles rim from	14" – 56"
Max. tire diameter	2400mm
Max. tire width	1300mm
Max. weight	1800kg
Max. bead breaking force	2690kg
Max. hydraulic working pressure	130 bar ± 10%
Net weight	1048kg
Package dimension	2276 x 1910 x 1095
Noise level in working condition	< 70 dB (A)

2.6 WARNING SIGNS

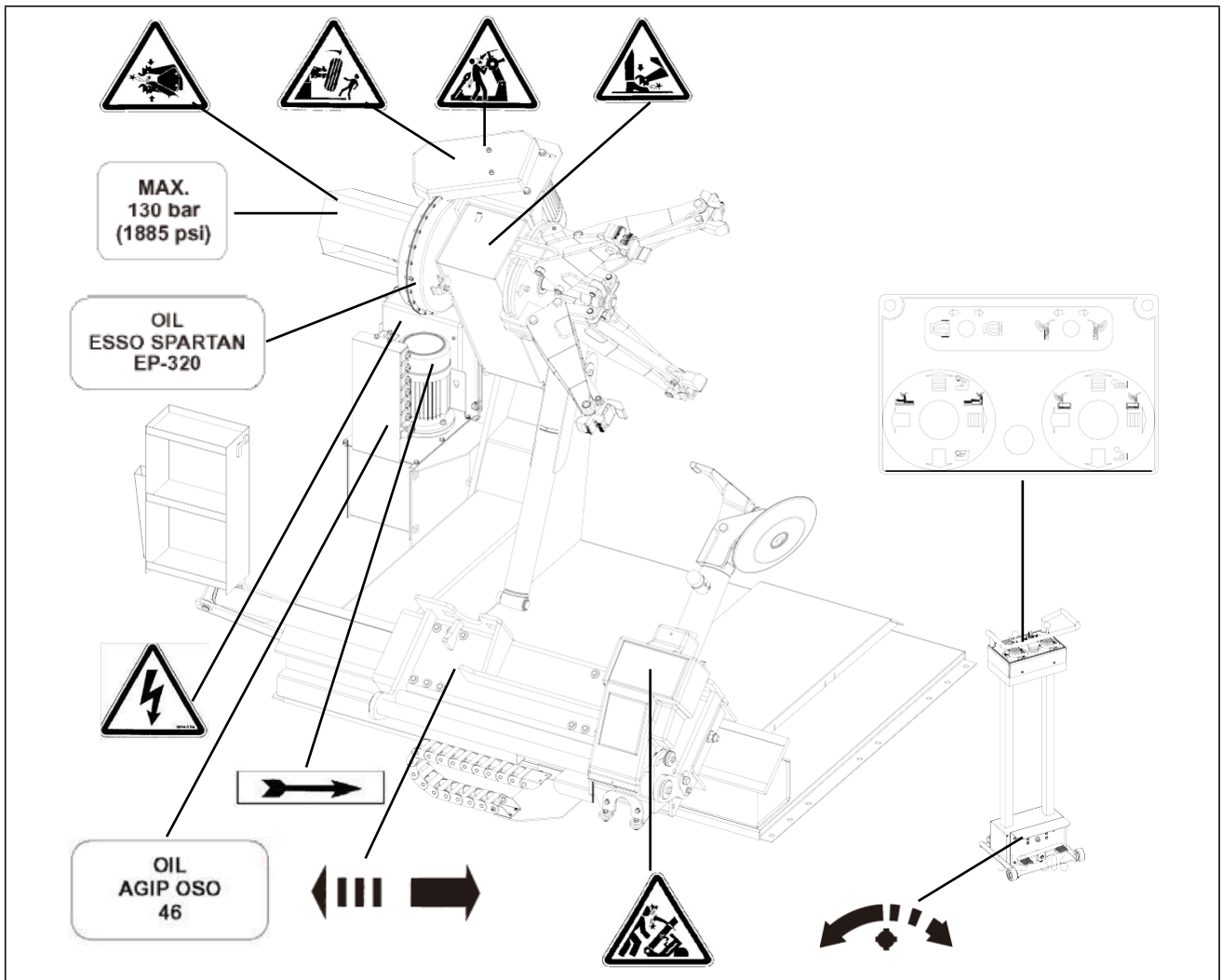

 Unreadable and missing warning labels must be replaced immediately. Do not use and add any object that could prevent the operator from seeing the labels.

CHAPTER 3 – TRANSPORTATION, UNPACKING AND STORAGE

3.1 TRANSPORTATION

- The machine must be transported in its original packaging and kept in the position shown on the package itself.
- The packaged machine may be moved by means of a fork lift truck of suitable capacity. Insert the forks at the points shown in fig. A/2.

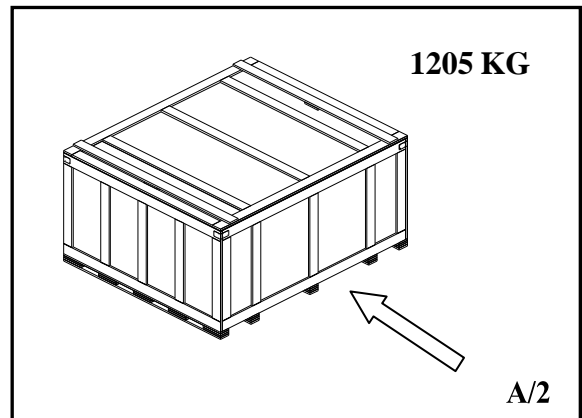

3.2 UNPACKING

- Remove the protective cardboard and the nylon bag.
- Check that the equipment is in perfect condition, making sure that no parts are damaged or missing.



If in doubt do not use the machine and contact your retailer.

3.3 STORAGE

Packages must be stored in a covered place, out of direct sunlight and in low humidity, at a temperature between -10°C and +40°C.

In the event of storage for long periods of time, be sure to disconnect all sources of power and grease the clamp sliding guides on the turntable to prevent them from oxidizing.

CHAPTER 4 – INSTALLATION

4.1 INSTALLATION SPACE REQUIRED



When choosing the place of installation, make sure that it complies with current safety at work regulations.

- The machine must be located on a flat floor of solid construction, preferably concrete. If the floor is uneven or broken, the machine will be not stable and the platform roller cannot move freely. Make sure the area has the adequate lighting.
- If the machine is installed outside it must be protected by a lean-to.
- The following work environment conditions are applicable:
 - Relative humidity from 30-95% without condensation;
 - Temperature from 0-55°C.

4.2 WORKPLACE REQUIRED

- Maximum machine space requirements are 2240x1640mm with a minimum distance from walls as shown in the diagram (see fig. B/5).



These measurements are also the tire changer working area. Persons other than specially trained and authorized operators are extremely forbidden to enter this area.

- Position the tire changer lifting it with the specific bracket (1-fig. A) with the tool carriage arm (2-fig. A) lowered all the way, the chuck (3-fig. A) closed and the sliding table (4-fig. A) at its stop close to the arm.
- The mobile control unit has not fixed position, but it must be positioned in a way that the user can observe the machine when working.

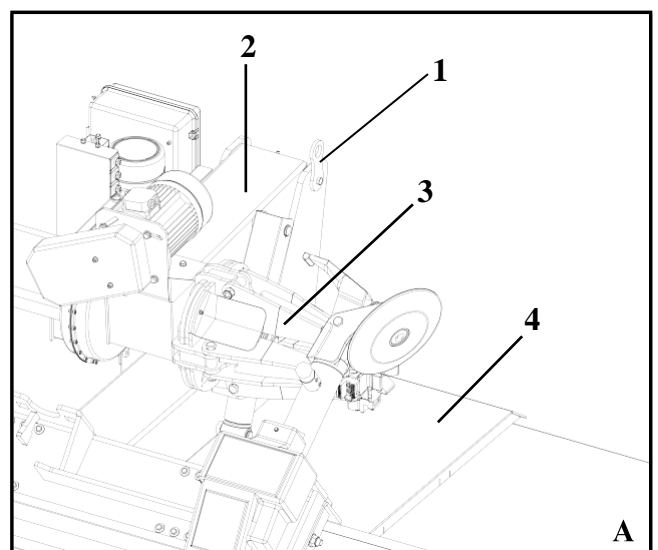
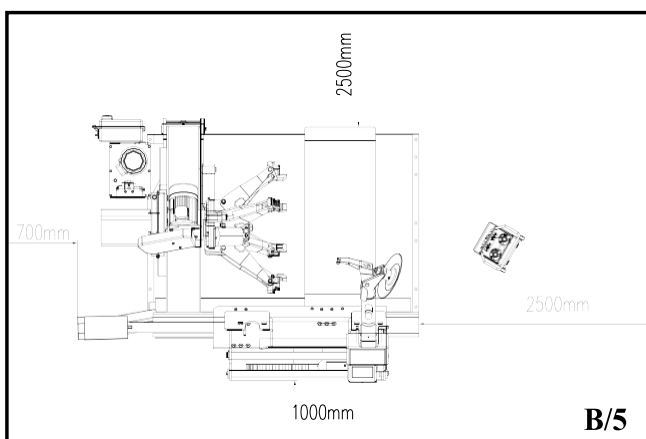

4.3 FOUNDATION REQUIREMENT

The tire changer should be installed on a leveled concrete floor at least 20cm thick with a minimum concrete quality of B25 in accordance with DIN 1045 requirements (foundations).

For your reference see the drawings as well as the table below.

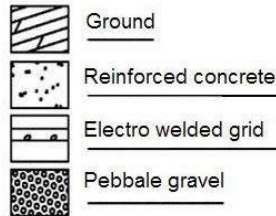
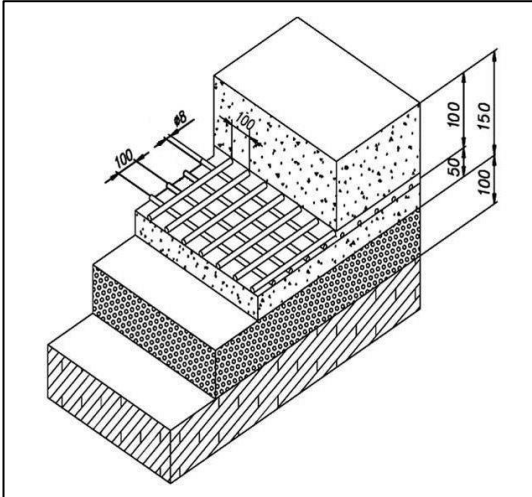

Foundations dimensions in cm.			Concrete quality	Min. pressure resistance
Length	Width	Thickness		
200	164	15	B25	425 Kg / cm ²

If a floor of this type is not available on site, fastening points of the specified concrete quality are acceptable.

- Surface, on which the tire changer is to be installed, must be flat and well leveled in all directions.
- Inclination up to 0.25% relative to the horizontal can be compensated using suitable shims, wedges or the alike.

	When working with wheels, which weight is higher than 1000kg, it is necessary to fasten the tire changer to the floor by means of proper anchor bolts.
--	---

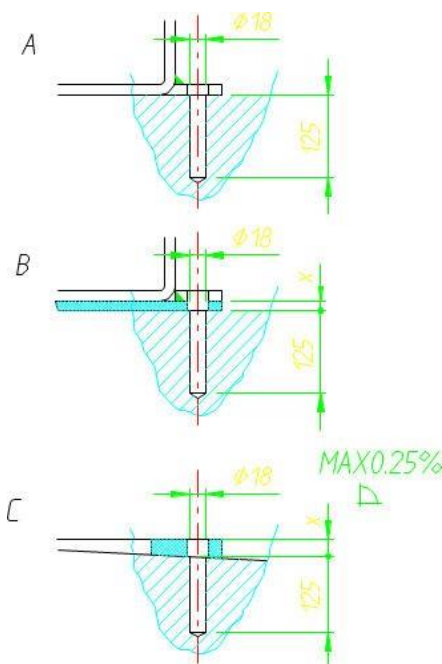

- By means of a hammer drill D.16, drill at least 130mm into the floor passing through the holes provided on the base frame.
- If there is an additional floor covering (B), or if shims or wedges are necessary for leveling (C), longer bolts must be used.
- Place an anchor bolt into each hole.
- Make sure the anchor bolts extend at least 125mm into the concrete slab, as indicated in the drawings.

4.4 ELECTRIC CONNECTION



Any electric connection job must be carried out by professionally qualified personnel.

- Check to make sure the characteristics of your systems correspond to those required by the machine. The supply voltage (and main frequency) is given on the machine nameplate. It cannot be changed.
- Connect the machine to the main electric power supply. If the machine does not include the electric plug, the user must set one, which must conform to the voltage of the machine, in compliance with the regulations in force.
- The machine should not be started up without proper grounding.



It is absolutely essential that:

The system must be grounded properly.

The machine is connected to a power supply line circuit breaker set for 10A.

The current intake is adequately protected against over currents with fuses or automatic magneto-thermic switch with rated value as shown in the table.

- Open the control panel;
- Switch one the breakers (fig. B/3)
- Switch “ON” (5 – fig. B/7) and check that the gearbox motor rotation corresponds to the indicating arrow (6 – fig. B/6).
- If not, switch two wires in the plug.

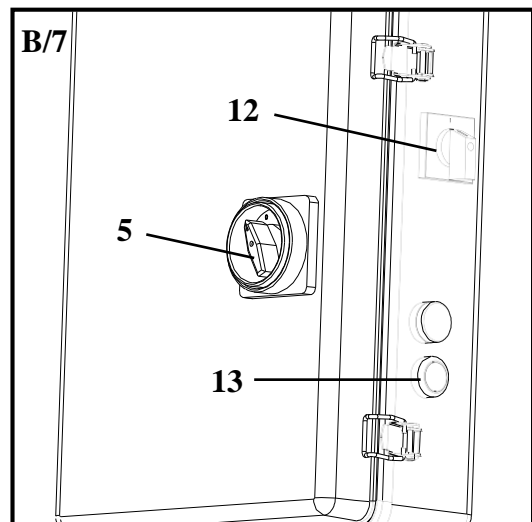
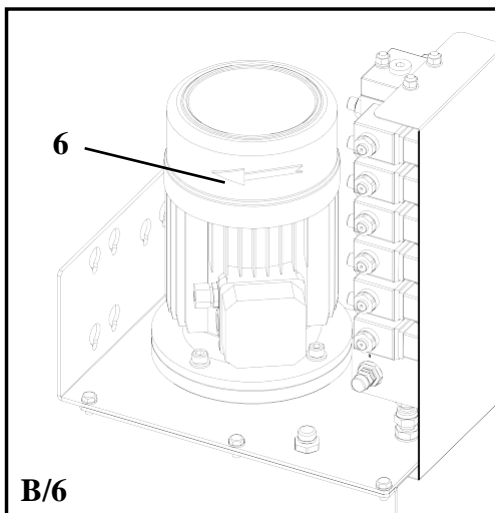

CHAPTER 5 – CONTROLS AND CHECKS

5.1 CONTROLS DESCRIPTION

The mobile control unit (fig. C) enables the operator choosing the most suitable work position around the machine. On this mobile control unit the following controls are located:

➤ **Joystick 1 (5, fig. C):**

- Move it to position [a] to raise the chuck arm.
- Move it to position [b] to lower the chuck arm.
- Move it to position [c] to moves the tool carriage and the sliding table towards the self-centering chuck.
- Move it to position [d] moves the tool carriage and the sliding table away from the self-centering chuck.

➤ **Joystick 2 (6, fig. C):**

- Move it to position [a] to lower the tool holder arm.
- Move it to position [b] to raise the tool holder arm.
- Move it to position [c] to moves the tool holder arm towards the self-centering chuck.
- Move it to position [d] moves the tool holder arm away from the self-centering chuck.

➤ **Chuck switch (7, fig. C):**

- Move it to position [c] to open the self-centering chuck.
- Move it to position [d] to close the self-centering chuck.

➤ **Tool switch (8, fig. C):**

- Move it to position [c] to turn the bead breaking disk (14, fig. D) to the working position.
- Move it to position [d] to turn the tool head (15, fig. D) to the working position.

➤ **Pedal (9, fig. C):**

- Depressing on the left or right side rotates the self-centering chuck in the same direction as shown by the arrows placed on the foot pedal. Both rotations can be made with two different speeds if the machine is ordered for 3 phase power supply. In this case, just placing the selector (12, fig. B/7) in position 1 for getting slow rotation and in position 2 for fast rotation

➤ **Emergency stop knob (10, fig. C):**

- Pressing it can stop the machine from working immediately in emergency.
- If you need to have the machine working later, you have to make the following operations,
 - Release the emergency stop button,
 - Press rest button (13 – fig. B/7) to start the machine.

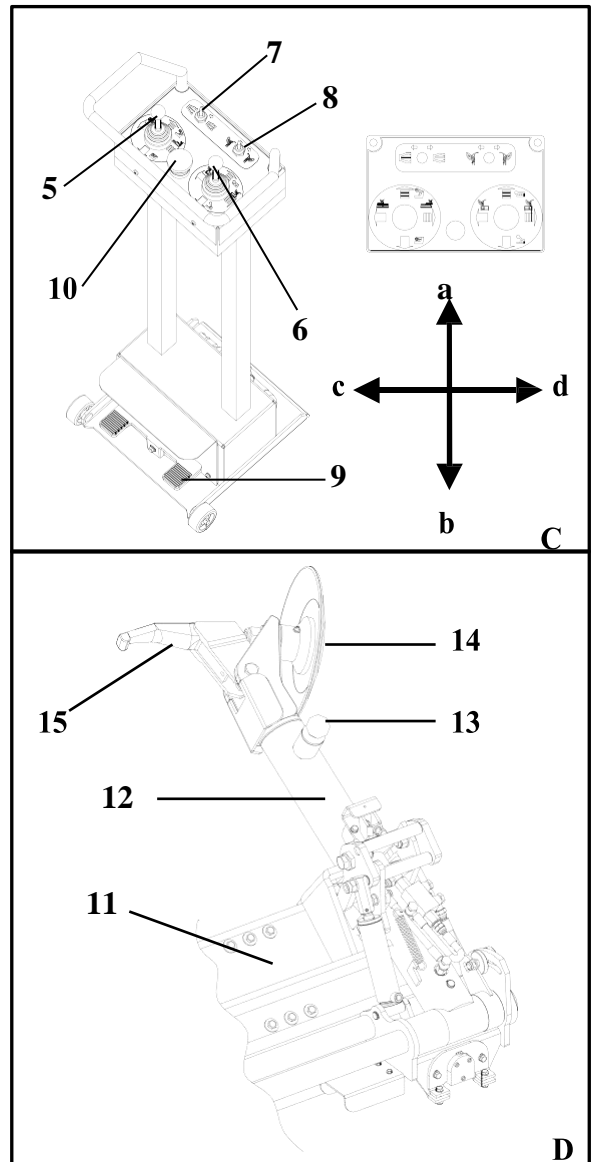

On the tool holder arm it is available the tool arm position knob (13, fig. D). By pulling it outwards, the tool arm can be extended.

5.2 CORRECT OPERATION CHECKS

Before use the tire changer, a number of checks should be made to ensure it works correctly,

	WARNING! Before any operation, make sure to check the hydraulic oil in the power unit and the engine oil in the reduction gear unit are enough. Add if necessary referring to the chapter 7. Manufacturer will not be responsible for any damage because the oil is not sufficient in the system.
---	--

	The operation described here should be done with the tool holder arm in its non-working position.
---	---

5.2.1 OPERATION CHECK OF JOYSTICK 1 (5, fig. C)

- Move the joystick 1 up: the chuck arm should be raised.
- Move the joystick 1 down: the chuck arm should be lowered.

	When the chuck arm is lowered, there is always a potential for crushing anything in its movement range. Always work from position given in the instructions keep well out of working range of the chuck arm.
---	---

- Move the joystick 1 leftwards: the tool carriage and the sliding table should move towards to the chuck. .
- Move the joystick 1 rightwards: the tool carriage and sliding table should move away from the chuck.
- Move the joystick 1 to all available positions and check for each related movement that must correspond to what described in chap 5.1 “CONTROL DESCRIPTION”.

5.2.2 OPERATION CHECK OF JOYSTICK 2 (6, fig. C)

	NEVER move your face close to the tool holder arm.
---	---

- Move the joystick 2 down: the tool holder arm should be raised.
- Move the joystick 2 up: the tool holder arm should be lowered.
- Move the joystick 2 leftwards: the tool holder arm should move towards the self-centering chuck.
- Move the joystick 2 rightwards: the tool holder arm should move away from the self-centering chuck.
- Move the joystick 2 to all available positions and check for each related movement that must correspond to what described in chap 5.1 “CONTROL DESCRIPTION”.

5.2.3 OPERATION CHECK OF CHUCK SWITCH (7, fig. C)



When the chuck arms open or closed, there is always a potential for crushing anything in their movement range. Always work from the positions given in the instructions keep well out of the chuck working range.

- Move the chuck switch leftwards: the chuck arm should open.
- Move the chuck switch rightwards: the chuck arm should close.

5.2.4 OPERATION CHECK OF TOOL SWITCH (8, fig. C)

- Move the tool switch leftwards: the tool unit should turn 180° clockwise so that the bead breaking disc should be on the working position.
- Move the tool switch rightwards: the tool unit should turn 180° anticlockwise so that the tool head should be on the working position.

•

5.2.4 OPERATION CHECK OF PEDAL (9, fig. C)

- Depress the right pedal: the chuck (3, fig. A) should turn clockwise.
- Depress the left pedal: the chuck (3, fig. A) should turn anticlockwise.

5.2.5 OPERATION CHECK OF EMERGENCY STOP (10, fig. C)

- Press the emergency stop knob: the electric circuit of the machine should be powered off and the machine should stop working.

5.2.6 HYDRAYLIC PRESSURE CHECK

Check to be certain the hydraulic circuit is working correctly:

- Move the chuck switch (7, fig. C) leftwards until the chuck is fully extended.
- Hold the chuck switch in this position (leftwards) and check if the pressure shown on the gauge on the swivel fitting (ref. B/1) is 130bar \pm 10%. **DO NOT USE THE MACHINES IF THE PRESSURE SHOWN IS NOT AS INDICATED HERE AND THEN CALL FOR THE SERVICE.**

CHAPTER 6 – OPERATION

6.1 WORKING POSITION

The diagram B/8 illustrates the various working positions (a, b, c, d) referred to in the following pages describing how to use the tire changer. Use of these positions ensures greater precision, speed and safety for using the machines.

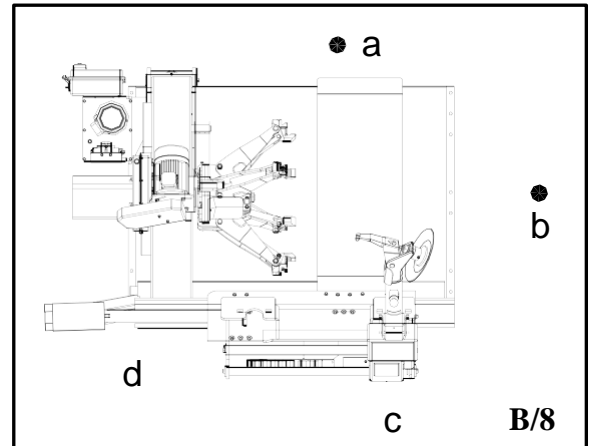

6.2 LOCKING THE WHEEL



In locking the wheel, make sure that clamps are properly positioned on the rim so as to prevent the tire from falling.

- **Take the mobile control unit to the working position [b].**
- Operate the joystick 2 to raise the tool holder arm (12, fig. D) into the upright position.
- Operate the joystick 1 to move the tool carriage and sliding table (11, fig. D and 4, fig. A) away from the chuck arm and place the wheel in vertical position on the sliding table





**This operation can be extremely dangerous.
Do it manually only if you are certain you can keep the wheel balanced.
For large and heavy tires an adequate lifting device must be used.**

- Continue to operate the joystick 1 to lift or lower the chuck arm in order to centre the self-centering chuck (3, fig. A) relative to the rim.
- With the jaws (12, fig. A) in the closed position, move the wheel on the sliding table to the self-centering chuck. Operate the chuck switch to open the self-centering chuck and lock onto the inside wheel rim.

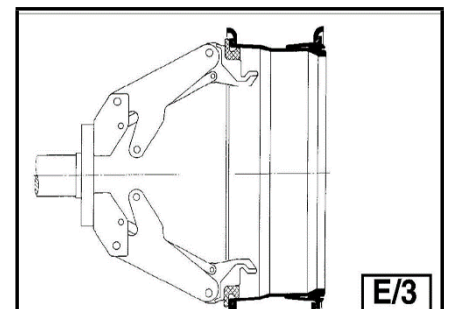
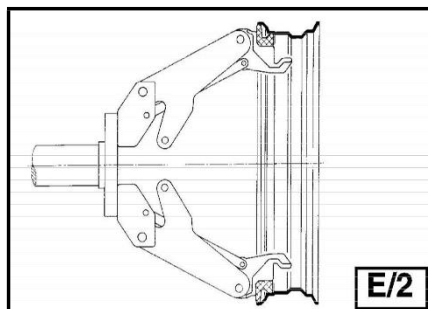
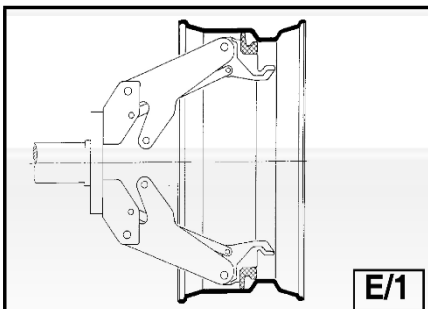
The most convenient locking position on the rim may be selected according to figs E/1-E/2-E/3-E/4-E/5 and E/6.

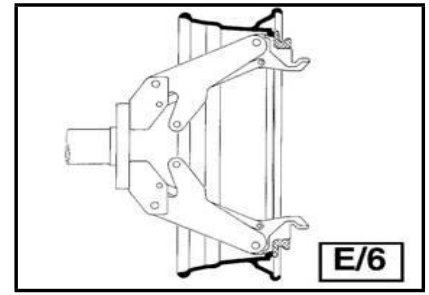
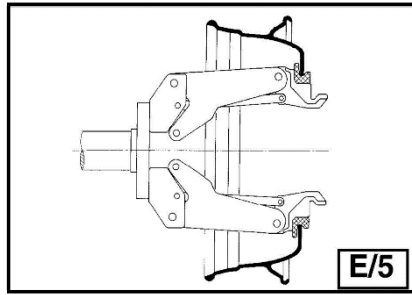
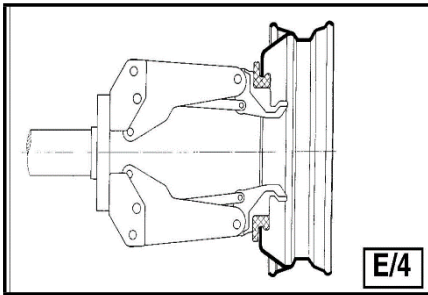





	<p>Always remember that the safest locking is on the central FLANGE.</p> <p>For rims with channel, clamp the wheel so that the channel is near the outside of the rim (fig. E/1).</p> <p>For rims exceeding a diameter of 46" and without a flange, clamp the wheel using the clamp extension Art 140/90, which can be ordered from the Manufacturer.</p>
---	--

6.3 LIGHT-ALLOY RIM LOCKING

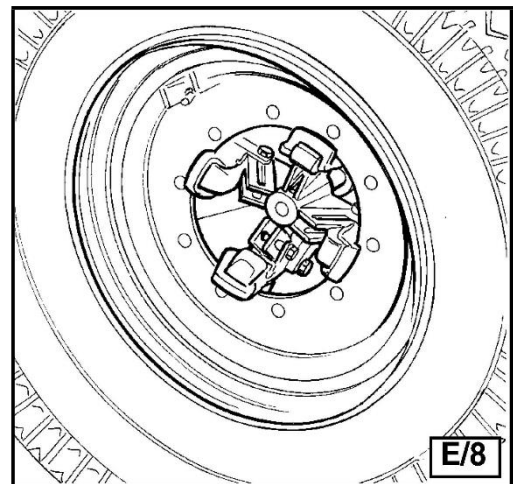
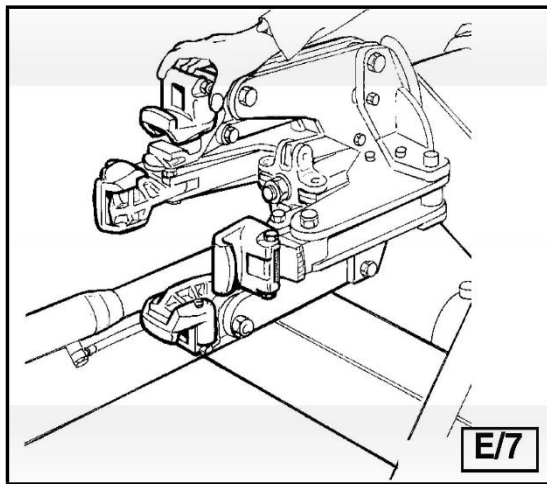
- Art. 137/90 clamp protections - especially designed for operating on light alloy rims without damaging them and are available upon request.
- The clamp protections are to be inserted (bayonet-like mounting) into the clamp support of the self-centering chuck (see fig. E/7).
- Lock the rim as illustrated in fig. E/8.
- The specially-made pliers Art.138/90 should be attached to the outside edge of the alloy rim at the highest point.



	<p>Do not leave the work area with a wheel clamped on the tire changer and lifted up from the floor.</p>
---	---

6.4 TUBELESS AND SUPERSINGLE WHEELS

6.4.1 BEAD BREAKING

- Lock the wheel on the self-centering chuck, as previously described, and ensure that the tire is deflated.

- Take the mobile control unit to the working position [c].
- Operate the joystick 2 to lower the tool holder arm (12, fig. D) into its working position and lock it.



Always check to be certain that the tool holder arm is correctly hooked to the carriage.

- Operate the mobile control unit to manoeuvre the wheel until the outside of the rim skims the bead-breaker disk (see. fig. F).



The bead breaker disk must NOT be pressed against the rim but against the tire bead.

- Rotate the wheel and at the same time advance the bead-breaker disk with small forward movements following the profile of the rim.
- Continue until the first bead is fully detached. To facilitate this operation, lubricate the bead and the edge of the rim with tire lubricant whilst the wheel is rotated.



To avoid all risks, lubricate the beads turning the wheel clockwise if you are working on the outside plane and anticlockwise if working on the inside plane.



Remember: stronger the tire's adherence to the rim, the slower must be the disk's penetration.

- Bring the tool holder arm (14, fig. F) back from the edge of the rim. Release the hook, raise the arm to its non-working position, shift it and re-hook it in its second work position (fig. G).



Do not hold your hands on the tool when you bring it back to its work position. Your hand(s) could be trapped between the tool and the wheel.

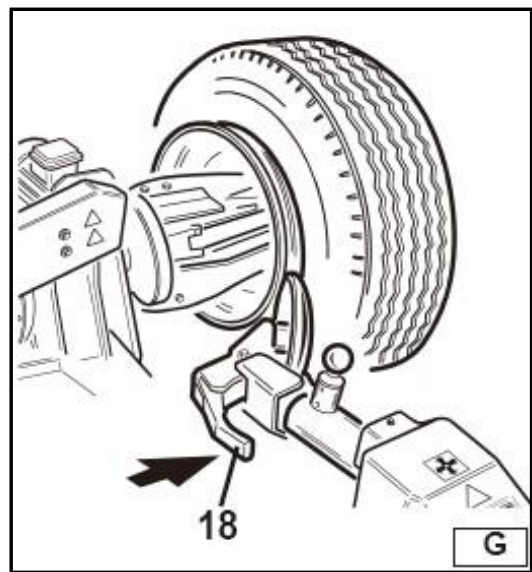
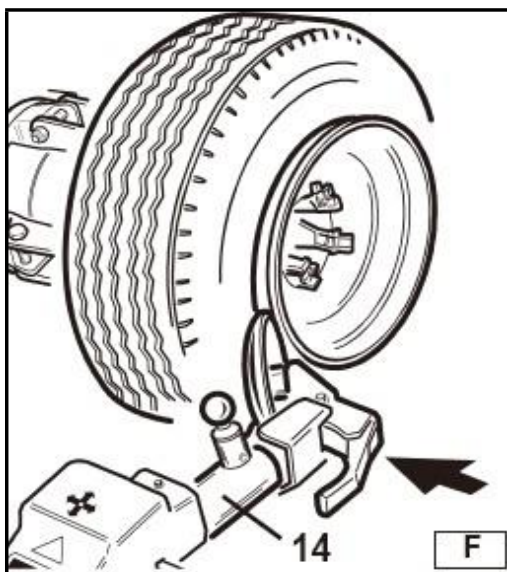

- Operate the tool switch (8, fig. C) to turn the tool head 180° until it locks automatically. Then operate the joystick 2 to slide the tool-holder arm along the carriage and lock it in position.

- **Take the mobile control unit to the working position [d].**
- Repeat the operation previously described until the second bead is completely detached.

	During the bead breaking, the tool head (18, fig. G) can be lowered so that it is out of the way.
---	--

6.4.2 DEMOUNTING

Tubeless tires can be demounted in two ways:

- If the tire is not difficult to be demounted, once the bead have been loosened, use the bead-breaker disk to push against the inside plane of the tire until both beads come off the rim (See fig. H).
- With Super-single or very hard tires the procedure described above cannot be used. The hook tool will have to be used as follows:
 - Move the tool holder arm to the outside plane of the tire.
 - **Take the mobile control unit to the working position [c].**
 - Rotate the wheel and at the same time move the hook tool forward to insert it between rim and bead until it is anchored to the bead (See fig. I).
 - Move the rim 4-5 cm from the tool taking care that it does not unhook from the bead.
 - Move the hook tool towards the outside until the reference dot is by the outside edge of the rim.
- **Take the mobile control unit to the working position [b].**
- Insert the lever (17, fig. I) between rim and bead at the right of the tool.
- Press down on the lever and lower the wheel to bring the edge of the rim about 5 cm from the hook tool.
- Turn the wheel anticlockwise pressing down on lever until the bead is completely off.
- Move the tool holder arm to its non-working position and then move it to the inside plane of the wheel.
- **Take the mobile control unit to the working position [d].**
- Turn the hook tool 180° and insert it between rim and bead (see fig. L). Move it until the bead is by the edge of the rim (best to do this with the wheel rotating).
- Move the rim about 4-5 cm from the tool making sure the hook does not detach from the rim.
- **Take the mobile control unit to the working position [b].**
- Move the hook tool so that its reference dot is about 3 cm inside the rim.
- Insert lever (17, Fig. I) between rim and bead at the right of the tool.
- Press down on the lever and lower the wheel to bring the

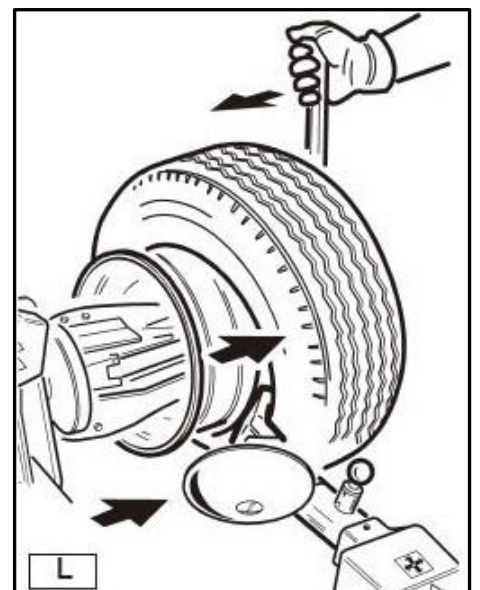
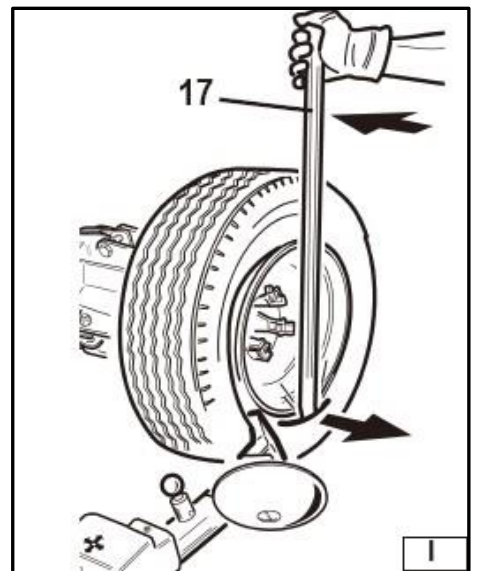
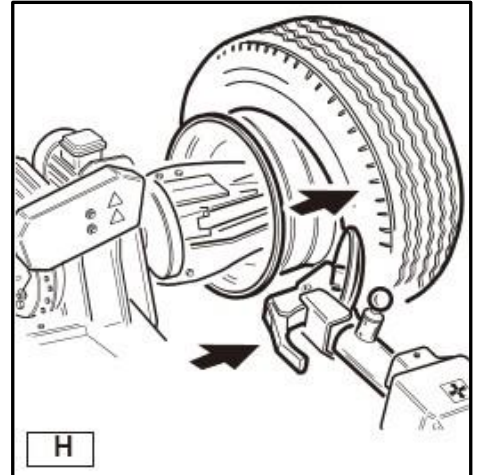

edge of the rim about 5 cm from the hooked tool.

- Rotate the wheel anticlockwise pressing down on lever until the tire comes completely off the rim.



When the beads come off the rim, the tire will fall. Check to make sure there are no by-standers in the work area.

6.4.3 MOUNTING

Tubeless tires can be mounted using either the bead breaker disk or the hook tool.

- If the tire is not problematic, use the bead-breaker disk.
- If the tire is very rigid, the hook tool must be used.

6.4.3.1 TIRE MOUNTING WITH THE DISK

- If the rim has been removed from the chuck, put it back on the chuck as described in the chap 6.2 on “LOCKING THE WHEEL”.
- Lubricate both beads and the rim with tire manufacturer recommended lubricant.
- Attach the clip to the outside edge of the rim at the highest point (See fig. M). **Make sure the clip is firmly attached to the rim.**
- **Take the mobile control unit to the working position [b].**
- Put the tire on the sliding table and lower the chuck arm (make sure the clip is at the high point).
- Lift the rim with the tire hooked and turn the chuck spindle anticlockwise about 15-20 cm. The tire will be tilted across the rim.

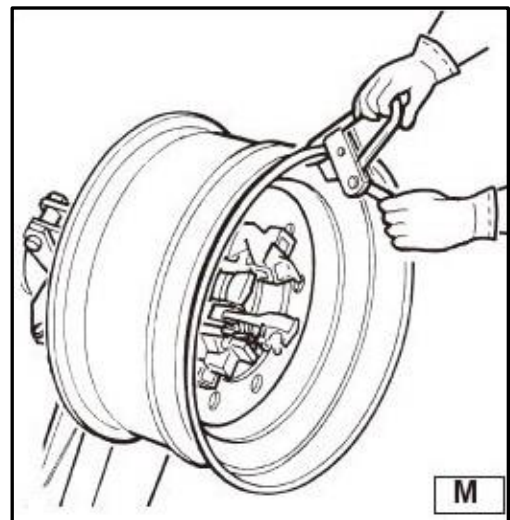

- **Take the mobile control unit to the working position [c].**
- Position the bead breaker disk against the second bead of the tire and turn the chuck spindle until the clip is at the low point (at 6 o'clock).
- Move the disk away from the wheel.
- Remove the clip and replace it at 6 o'clock outside the second bead (See fig. N).
- Turn the chuck spindle clockwise 90° to bring the clip to 9 o'clock.
- Move the disk forward until it is about 1-2 cm inside the edge of the rim. Begin to turn the chuck spindle clockwise checking to make sure that, with a 90° turn, the second bead begins to slip into the centre well.
- When the bead is fully mounted, move the tool away from the wheel, tip it to its non-working position and remove the clip.
- Position the sliding table (4, fig. A) under the wheel, lower the chuck until the wheel rests on the sliding table.

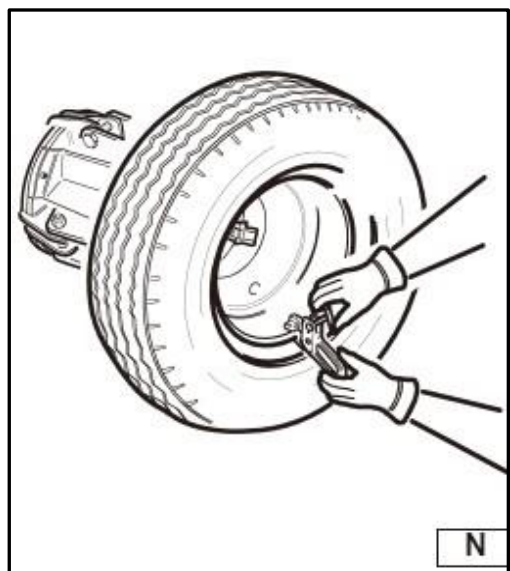

- **Take the mobile control unit to the working position [b].**
- Close the chuck completely and support the wheel to prevent it falling off.



**This operation can be extremely dangerous.
Do it manually only if you are certain you can keep the wheel balanced.
For large and heavy tires an adequate lifting device must be used.**

- Move the sliding table to remove the wheel from the chuck.
- Lower the sliding table and remove the wheel.



If the tire permits, the operation described above can be speeded up by mounting both beads at the same time.

6.4.3.2 MOUNTING WITH THE HOOKED TOOL

- Follow the steps described in above points for mounting with the disk.
- Move the tool carrier arm to its non-working position. Move it to the inside plane of the tire and re-hook it at this position.
- Check to make sure the hook tool is positioned on the wheel side. If not, operate the tool switch (8, fig. C) and turn it 180°.
- **Take the mobile control unit to the working position [d].**
- Move the tool forward until the reference dot is lined up with the outside edge of the rim and about 5 mm from it (see fig. O).
- **Take the mobile control unit to the working position [c].**
- Move the tool to the outside of the wheel and check the exact position. Then turn the chuck spindle clockwise until the clip is at the bottom (6 o'clock). The first bead will be on the rim. Remove the clip.
- **Take the mobile control unit to the working position [d].**
- Remove the tool from the tire.
- Move the tool holder arm to its non-working position. Move it to the outside plane of the tire and re-hook it in this position.
- Turn the tool 180° with the tool switch (8, fig. C).
- Attach the clip at the bottom (6 o'clock) outside the second bead (See fig. N).
- **Take the mobile control unit to the working position [c].**
- Turn the chuck spindle clockwise to about 90° (clip at 9 o'clock).
- Bring the tool forward until the red reference dot is lined with the outside edge of the rim about 5 mm from it. Begin to turn the chuck spindle clockwise and check if, after about 90° of rotation, the second bead has started to slip into the centre well. Continue turning until the clip is at the bottom (6 o'clock). The second bead will now be mounted on the rim.
- Follow the steps described in points above for mounting with the disk since this will ensure that the wheel is removed correctly from the machine.

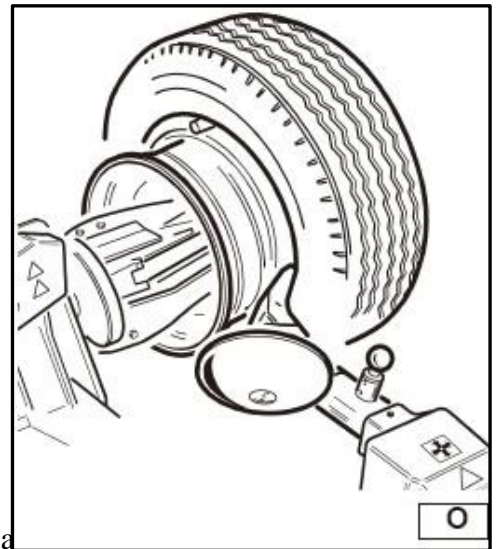

6.5 TUBED WHEELS

6.5.1 BEAD BREAKING



Warning: Unscrew the bush which fixes the valve when deflating the tire so that the valve, coming in the inside of the rim, is not an obstacle during bead breaking.

- Follow all the steps described previously for bead breaking tubeless tires.
- With tubed tire, however, stop the disk movement immediately when the bead has loosened to avoid damaging the tube inflation valve.

6.5.2 DEMOUNTING

- **Take the mobile control unit to the working position [c].**
- Tip the tool holder arm (12, fig. D) to its non-working position. Move it to the outside plane of the wheel and re-hook it in this position.
- Rotate the wheel and at the same time move the hook tool (15, fig. D) forward inserting it between rim and bead until it is anchored to the tool.
- Move the rim about 4-5 cm from the tool taking care that it does not unhook from the bead.
- Move the hook tool towards the outside until the reference dot is by the outside edge of the rim.

- **Take the mobile control unit to the working position [b].**
- Insert the lever (see fig. P) between rim and bead at the right of the tool.
- Press down on the lever and lower the wheel to bring the edge of the rim about 5 mm from the hooked tool.
- Turn the wheel anticlockwise pressing down on lever until the bead is completely off.
- Move the tool holder arm to its non-working position. Lower the chuck arm until the tire is pressed down against the sliding table. When the sliding table moves slightly towards the outside, the tire will open a little and thus create enough space to remove the inner tube.
- Remove the inner tube and lift wheel up.

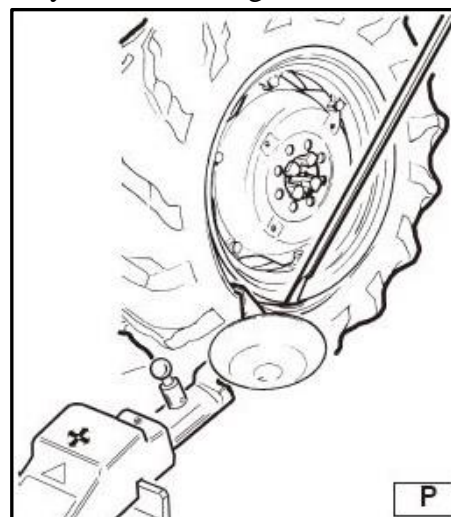

- **Take the mobile control unit to the working position [d].**
- Move the tool holder arm to the inside plane of the tire. Turn the hook tool 180° and lower the arm to its working position. Insert the hook tool between rim and bead, and move it until the bead is by the edge of the rim (best to do this with the wheel turning).
- Move the rim about 4-5 cm from the tool making sure the hook does not detach from the rim.

- **Take the mobile control unit to the working position [b].**
- Move the hook tool so that it is about 3 cm inside the rim.
- Insert the lever between rim and bead at the right of the tool (See fig. Q).
- Press down on the lever and lower the wheel to bring the edge of the rim about 5 cm from the hooked tool. Turn the wheel anticlockwise pressing down on

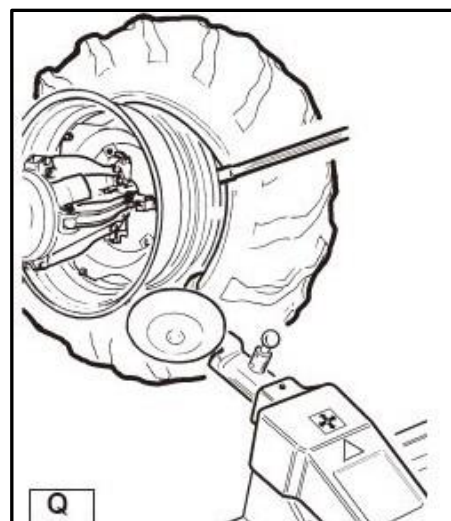

the lever until the tire comes completely off the rim.



**When the beads come off the rim, the wheel will fall.
Check to make sure there are no by-standers in the work area.**

6.5.3 MOUNTING

- If the rim has been removed from the spindle, put it back on the spindle as described in the chap 6.2 on “LOCKING THE WHEEL”.
- Lubricate both beads and the rim with tire manufacturer recommended lubricant.
- Attach the clip to the outside edge of the rim at the highest position (see fig. R). Make sure the clip is firmly attached to the rim.
- **Take the mobile control unit to the working position [b].**
- Put the tire on the sliding table and lower the chuck (make sure the clip is at the high point) to hook the first bead on the clip.
- Lift the rim with the tire hooked to it and turn it anticlockwise about 15-20 cm. The tire will be tilted across the rim.
- Move the tool holder arm to its non-working position. Move it to the inside plane of the tire and re-hook it in this position.
- Check to make sure the hook tool is positioned on the wheel side. If not, operate the tool switch (8, fig. C) and turn it 180°.
- **Take the mobile control unit to the working position [d].**
- Move the tool forward until the reference dot is lined up with the outside edge of the rim and about 5 mm from it (see fig. S).
- **Take the mobile control unit to the working position [c].**
- Move to the outside of the wheel and check the exact position of the hook visually and adjust it as needed. Then turn the chuck spindle clockwise until the clip is at the bottom (6 o'clock). The first bead will be on the rim. Remove the clip.
- **Take the mobile control unit to the working position [d].**
- Remove the tool from the tire.
- Move the tool holder arm to its non-working position. Move it to the outside plane of the tire.
- Turn the tool 180° by operating the tool switch (8, fig. C).

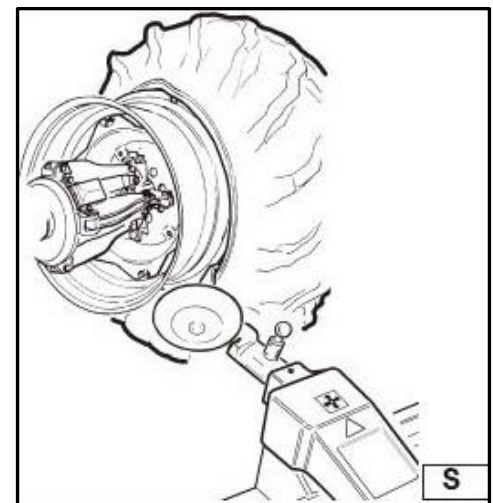
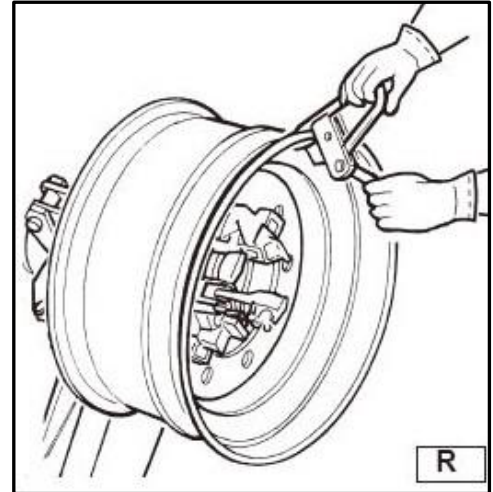

- **Take the mobile control unit to the working position [b].**
- Turn the chuck spindle until the valve hole is at the bottom (6 o'clock).
- Move the sliding table (4 fig. A) under the wheel and lower the chuck arm until the tire is pressed down against the sliding table. When the sliding table moves slightly towards the outside, the tire will open a little and thus create enough space to insert the inner tube.
- Insert the valve through the hole and fix it with its locking ring.
- The valve hole may be asymmetrical to the centre of the rim. In this case position and insert the inner tube as shown in Fig. T.
- Place the inner tube in the center well of the rim (to facilitate this, turn the chuck spindle clockwise).
- Turn the chuck spindle until the valve is at the bottom (6 o'clock).
- Inflate the inner tube a little (until it has no folds) so as not to pinch it while mounting the second bead.
- Attach an extension to the valve and then remove the locking ring (the purpose of this operation is to allow the valve to be loose so that it is not ripped out during the second bead mounting).

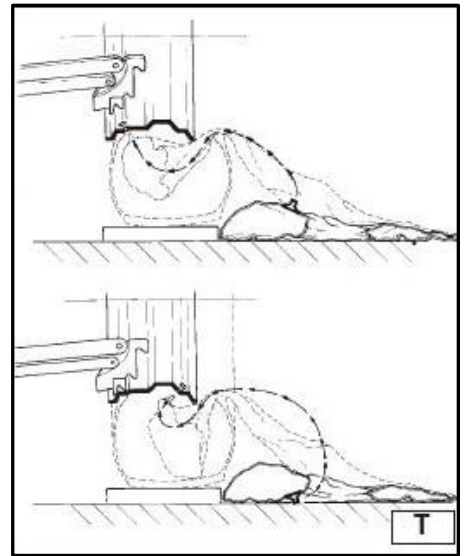

- **Take the mobile control unit to the working position [c].**
- Lift the wheel again and attach the clip outside the second bead about 20 cm to the right of the valve (see fig. U).
- Turn the chuck clockwise until the clip is at 9 o'clock.
- Move the tool holder arm (12, fig. D) to its working position.
- Bring the tool forward until the reference dot is lined up with the outside edge of the rim and about 5 mm from it.
- Turn the chuck spindle a little clockwise until the bead lever can be inserted its seating on the hook tool.
- Pull back on the lever to let the bead into centre well. Continue to turn the chuck until the tire is completely mounted on the rim.
- Remove the clip. Remove the hook tool by turning the chuck spindle anticlockwise and moving it towards the outside.
- Tip the tool holder arm to its non-working position.
- Position the sliding table directly under the wheel and lower the chuck arm until the wheel rests on the sliding table.

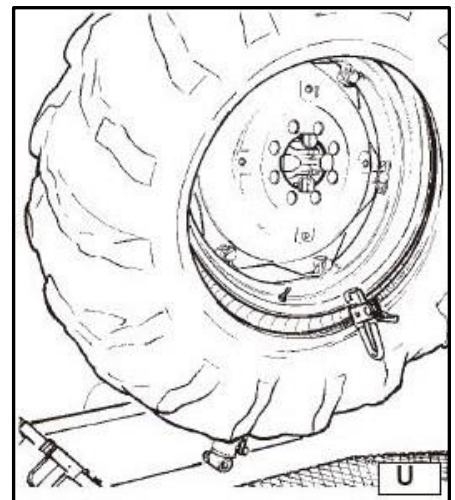

- **Take the mobile control unit to the working position [b].**
- When the wheel is resting on the sliding table, check to make sure the valve is perfectly centered with its hole. If it is not, turn the chuck spindle slightly to adjust the position. Fix the valve with its locking ring and remove the extension.
- Close the chuck completely and support the wheel to prevent it falling off.



**This operation can be extremely dangerous.
Do it manually only if you are certain you can keep the wheel balanced.
For large and heavy tires an adequate lifting device must be used.**

- Move the sliding table to release the wheel from the chuck spindle. Remove the wheel.

6.6 WHEELS WITH SPLIT RING

6.6.1 BEAD BREAKING AND DEMOUNTING

6.6.1.1 WHEELS WITH 3-PIECE RINGS

- Clamp the wheel on the chuck as described previously and check to make sure it has been deflated.
- **Take the mobile control unit to the working position [b].**
- Lower the tool holder arm (12, fig. D) to its work position until it is locked in position by its hook.
- Position the bead breaker disk toward the rim (See fig. W).
- Turn the chuck spindle and at the same time move the disk forward a bit at a time following the contour of the rim until the first bead is completely free (**lubricate while doing this**).

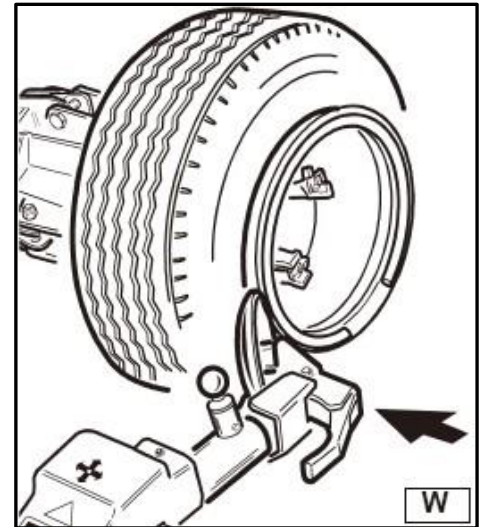

If the tire has an inner tube, work very carefully and be prepared to stop the disk immediately once the bead has been detached so as not to damage the valve and the inner tube.

- Repeat this procedure but this time bring the disk against the split-ring (See fig. Z) until the lock ring is free. Remove this with the special lever Art.148/90 upon request (19, fig. Z) or with the help of the disk.
- Remove the split-ring.
- Move the tool holder arm (12, fig. D) back from the edge of the rim. Release the hook and tip the arm to its non-working position.
- Move the tool holder arm to the inside plane of the wheel.
- Operate the tool switch (8, fig. C) and turn the tool head 180° which will automatically lock in this position. Lower the tool holder arm to its working position.
- Turn the chuck spindle and at the same time bring the bead breaker disk up against the tire following the contour of the split-ring until the second bead has been detached (**lubricate during this process**). Continue to move the disk forward until about half the tire has detached from the rim (see fig. K).
- Move the tool holder arm to its non-working position.
- Move the sliding table (4 fig. A) directly under the wheel.
- Lower the chuck arm until the wheel is resting on the sliding table.
- **Take the mobile control unit to the working position [b].**
- Move the sliding table towards the outside until the tire is completely off the rim. **Watch out for the valve!**

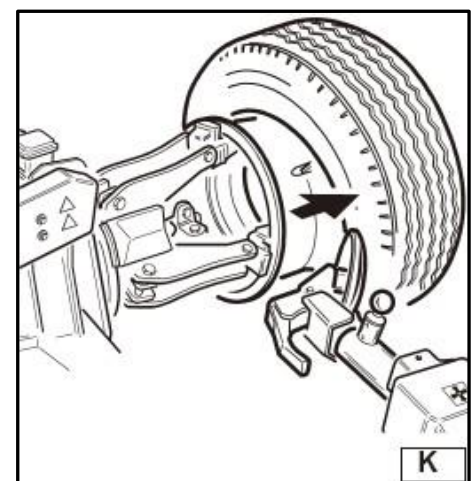
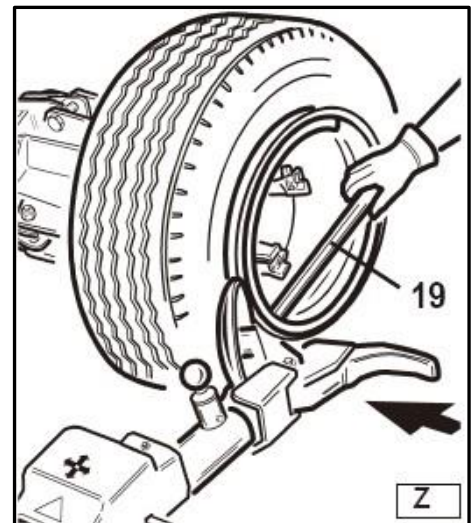

6.6.1.2 WHEELS WITH 5-SEGMENT SPLIT RINGS

- Clamp the wheel on the chuck as described previously and make sure it is deflated.
- **Take the mobile control unit to the working position [b].**
- Lower the tool holder arm to its work position until its hook has clicked into position.
- Use the tool switch (8, fig. C) to position the wheel so that the bead breaker disk touches up against outside edge of the centre well rim.
- Turn the chuck spindle and at the same time move the bead breaker disk forward until the splitting ring is detached. **Watch out for the ring!**
- Repeat this operation but this time move the disk against the split-ring (See fig. Z) until the locking ring is released this ring can be removed with the special lever Art.148/90 (19, fig. Z) or with the help of the bead disk.
- Remove the ring
- Move the tool holder arm back from the edge of the rim. Release the hook and tip the arm to its non-working position.
- Move the tool holder arm to the inside plane of the wheel.
- Operate the tool switch (8, fig. C) and turn tool head 180° which will automatically lock in this position. Lower the tool holder arm to its working position.
- **Take the mobile control unit to the working position [d].**
- Turn the chuck spindle and at the same time bring the bead breaker disk up against the tire between the rim and bead. Move the disk into the tire only when the bead has started to detach from the rim and move the bead to the outside edge of the rim (**lubricate during this process**).
- Tip the tool holder arm to its non-work position.
- **Take the mobile control unit to the working position [b].**
- Move the sliding table (4, fig. A) directly under the wheel.
- Lower the chuck arm until the wheel is resting on the platform.
- Move the sliding table towards the outside until the tire together with the split ring comes completely off the rim.
- Remove the rim from the chuck.
- Position the tire on the sliding table with the splint ring turned towards the chuck spindle.
- Clamp the split ring on the chuck as explained in the chap 6.2 “LOCKING THE WHEEL”.



The tire is not attached to the split ring completely safely. Any strain on it during positioning or clamping operations could cause it to detach and fall.

- **Take the mobile control unit to the working position [d].**
- Lift the wheel.
- Move the tool holder arm back to its work position.
- Position the chuck spindle so that the bead breaker disk is lined up with the bead.
- Turn the chuck spindle and move the disk forward until the tire comes completely off the split ring.



When the beads come off the rim, the wheel will fall. Check to make sure there are no by-standers in the work area.

6.6.2 MOUNTING

6.6.2.1 WHEELS WITH 3-PIECE SPLIT-RINGS

- Move the tool holder arm to its non-working position. If the rim has been removed from the chuck, put it back on the spindle as described in the chap 6.2 “LOCKING THE WHEEL”.
- If the tire is tubed, position the rim with the valve slot at the bottom (6 o'clock).
- Lubricate both beads and the rim with tire manufacturer recommended lubricant.
- **Take the mobile control unit to the working position [b].**
- Move the sliding table so as to be able to place the tire on it. **If the tire is tubed, position the rim with the valve slot at the bottom (6 o'clock).**
- Lower or raise the chuck arm to centre the rim.
- Move the sliding table forward until the rim is inserted into the tire. **If the tire is tubed, push the valve inside so as not to damage it.**
- Move the sliding table forward until is rim is completely in the tire.
- Bring the tool holder arm to the outside plane and lower it to its work position with the disk towards the wheel. **If the tire is not inserted sufficiently on the rim, move the chuck spindle until the tire bead is by the disk.**
- Bring the disk forward (with the chuck spindle turning) until it is completely inserted.
- Put the split-ring on the rim and then install the locking ring with the help of the disk as shown in the figure Y.
- Move the tool holder arm to its non-working position and at the same time close the chuck. Support the wheel so that it does not fall off.
- Move the sliding table to free the wheel from the chuck.
- Remove the wheel.

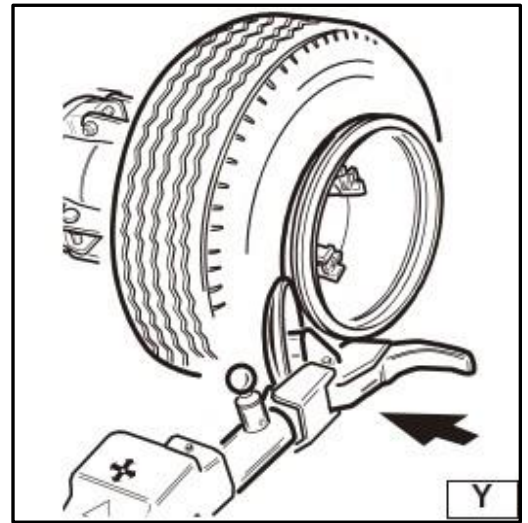

This operation can be extremely dangerous.

Do it manually only if you are certain you can keep the wheel balanced.

For large and heavy tires an adequate lifting device must be used.

6.6.2.2 WHEELS WITH 5-SEGMENT SPLIT-RINGS

- Move the tool holder arm to its non-working position. If the rim has been removed from the chuck, put it back on the chuck as described in the chap 6.2 “LOCKING THE WHEEL”.
- Lubricate both beads and the rim with tire manufacturer recommended lubricant.
- **Take the mobile control unit to the working position [b].**
- Move the sliding table so as to be able to place the tire on it.
- Lower or raise the chuck arm to centre the rim and the tire.
- Move the sliding table forward until the rim is inserted into the tire. Move the platform forward until rim is completely in the tire.
- Put the split-ring on the rim with the lock ring already mounted. **If the rim and the split-ring have the slits for fixing the devices, make sure they are lined up with each other.**

- **Take the mobile control unit to the working position [c].**
- Move the tool holder arm to the outside in its work position with the bead breaker disk turned towards the wheel. **If the split-ring is not inserted sufficiently on the rim, move the spindle until the split-ring is by the disk. Bring the disk forward (with the chuck spindle turning) until the O-ring is seated.**
- Lubricate the O-ring and its seating.
- **Take the mobile control unit to the working position [b].**
- Position the locking ring on the rim with the help of the disk as shown in Fig.Y.
- Move the tool holder arm to its non-working position and close the chuck completely. Support the wheel so that it does not fall off the spindle.



**This operation can be extremely dangerous. Do it manually only if you are certain you can keep the wheel balanced.
For large and heavy tires an adequate lifting device must be used.**

- Move the sliding table so as to free the wheel from the chuck.
- Remove the wheel.



**Do not inflate the tire with the wheel mounted on the chuck.
Tire inflation is dangerous and should only be done by removing the wheel from the chuck and placing it inside a safety cage.**

CHAPTER 7 - ORDINARY MAINTENANCE



Each maintenance operation must be effected only after the disconnection of the plug from electric network.

To ensure that this tire changer works perfectly over the years, carry out the routine maintenance schedule described below:

- Lubricate the following parts from time to time, after a thorough cleaning with naphtha:
 - the various swivels on the spindle
 - the tool bracket slide runner
 - the carriage guide plate
- Grease the cylinders from time to time and also their swivels. Add the grease through the grease nipples (See fig. J) using ordinary lubricating grease.
- From time to time check the oil level in the hydraulic power pack. Use the dipstick under the reservoir cap.
- If necessary top up with AGIP OSO H46 or similar hydraulic oil.
- From time to time check the oil level in the gear unit which, when the tool carrier bracket is completely lowered at end travel, should not show the sight glass on the gear casing as completely empty. If necessary top up with Esso Spartan EP 320 or similar oil.

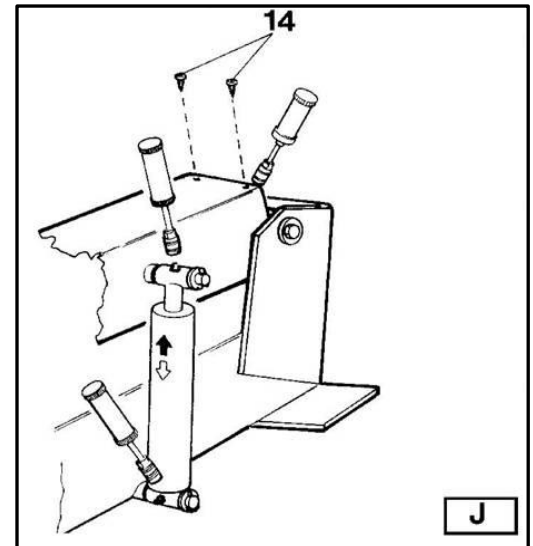

**If the oil in the gear unit or the hydraulic power pack has to be changed, note that the gear unit casing and the power pack reservoir have specific drain plug.
Chang oil at 1 year intervals at least!**



WARNING! Before any operation, make sure to check the hydraulic oil in the power unit and the engine oil in the reduction gear unit are enough. Add if necessary referring to the chapter 7. Manufacturer will not be responsible for any damage because the oil is not sufficient in the system.



Dispose of the used oil following the present legislation on the matter.

CHAPTER 8 - TROUBLE SHOOTING

TROUBLE:	POSSIBLE CAUSE:	SOLUTION:
After having switched on the power switch, the pilot lamp does not light on and no control can function.	The power plug is not inserted.	Insert the plug correctly in its socket.
	No power from the mains electric supply.	Reset the mains electric supply.
After having switched on the power switch, the pilot lamp light on but the motor on the hydraulic power pack does not function.	The circuit breaker is not switched on.	Switch on the circuit breaker.
	The thermal relay for motor protection is working.	Call for technical assistance.



If, despite of the above mentioned indications the tire changer does not work properly, do not use it and call for technical assistance.

CHAPTER 9 – MOVING, STORING AND SCRAPPING

9.1 MOVING THE MACHINE

The tire changer has got the lifting bracket (1, Fig. A) which has been positioned there on purpose for moving the machine.

To move the machines, follow these instructions:

- Low the chuck arm (2, Fig. A) completely down.
- Close completely the self-centering chuck (3, Fig. A).
- Bring the sliding table (4, Fig. A) at the end of its travel closed to the chuck arm.
- Insert into the lifting bracket a hoisting belt (at least 60 mm wide and of a length sufficient to bring the hook of the belt above the tire changer).
- With the special belt ring bring the 2 ends of the belt together and lift the machine with a sufficiently strong lifting truck.

9.2 STORING

If the machine as to be stored for a long time (3-4 months) you have to:

- Close the chuck; low the chuck arm down; low the tool holder arm down in working position.
- Disconnect the machine from all power sources.
- Grease all the parts that could be damaged if they dry out:
 - the chuck
 - the slot of the tool holding arm
 - the slides of the carriage
 - the tool
- Empty oil/hydraulic fluid reservoirs and wrap the machine in a sheet of protective plastic to prevent dust from reaching the internal working parts.

If the machine needs to be working again after a long storing period, it is necessary to:

- Fill the oil into the reservoirs again.
- Restore the electric connection.

9.3 SCRAPPING A MACHINE

When your machine's working life is over and it can no longer be used, it must be made inoperative by removing any connection to power sources.

These units are considered as special waste material, and should be broken down into uniform parts and disposed of in compliance with current laws and regulations.

If the packing are not polluting or non-biodegradable, deliver them to appropriate handling station.



If this machine catches fire, use dust or CO2 extinguishers only.

CHAPTER 10 – OPTIONAL ACCESSORIES

The following optional accessories are available for the tire changer:



137/90 Set of 4 jaws for alloy rims

Mounted on the jaws of the chuck, they are used to operate on alloy rims without damaging them.



138/90 Pliers for alloy rims

It is used to work with alloy rims without damaging them.

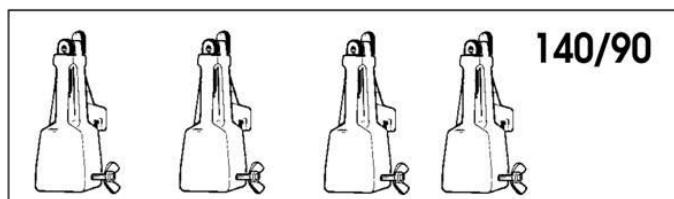

140/90 set of clamp extensions

Mounted on the jaws of the chuck, they are used for rims diameter from 46" to 56".

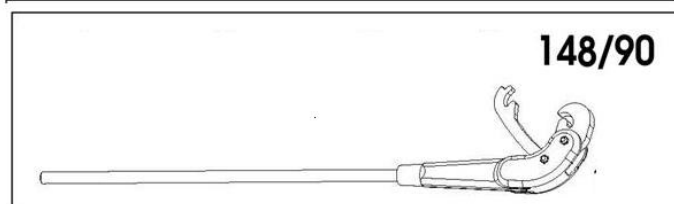

148/90 Ring lever

For the wheels with rings, it is used to facilitate to split and lift the rings from the rim

CHAPTER 11 - HYDRAULIC SCHEME AND ELECTRIC DIAGRAM

HYDRAULIC SCHEME

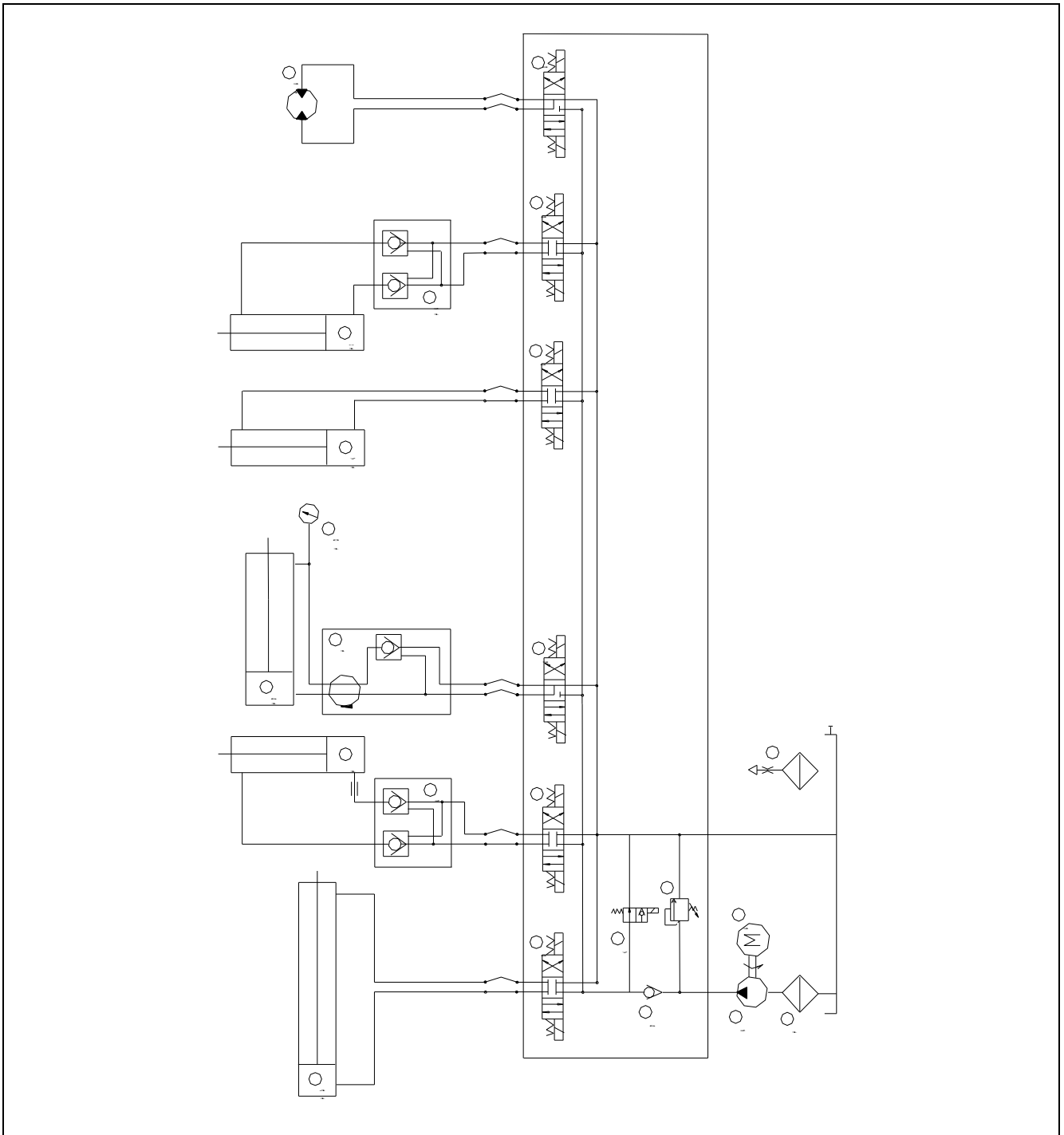

1	Oil filter	10	Pressure gauge
2	Gear pump	11	Stop valve – chuck opening/closing cylinder
3	Pump motor	12	Stop valve – tool rotation cylinder
4	Oil level plug	13	Hydraulic motor – carriage cylinder
5	Pressure overload valve	14	Carriage cylinder
6	Check valve	15	Chuck arm lifting cylinder
7	Circuit loading solenoid valve	16	Chuck opening/closing cylinder
8	Modular directional solenoid valve	17	Tool arm cylinder
9	Modular directional solenoid valve	18	Tool rotation cylinder

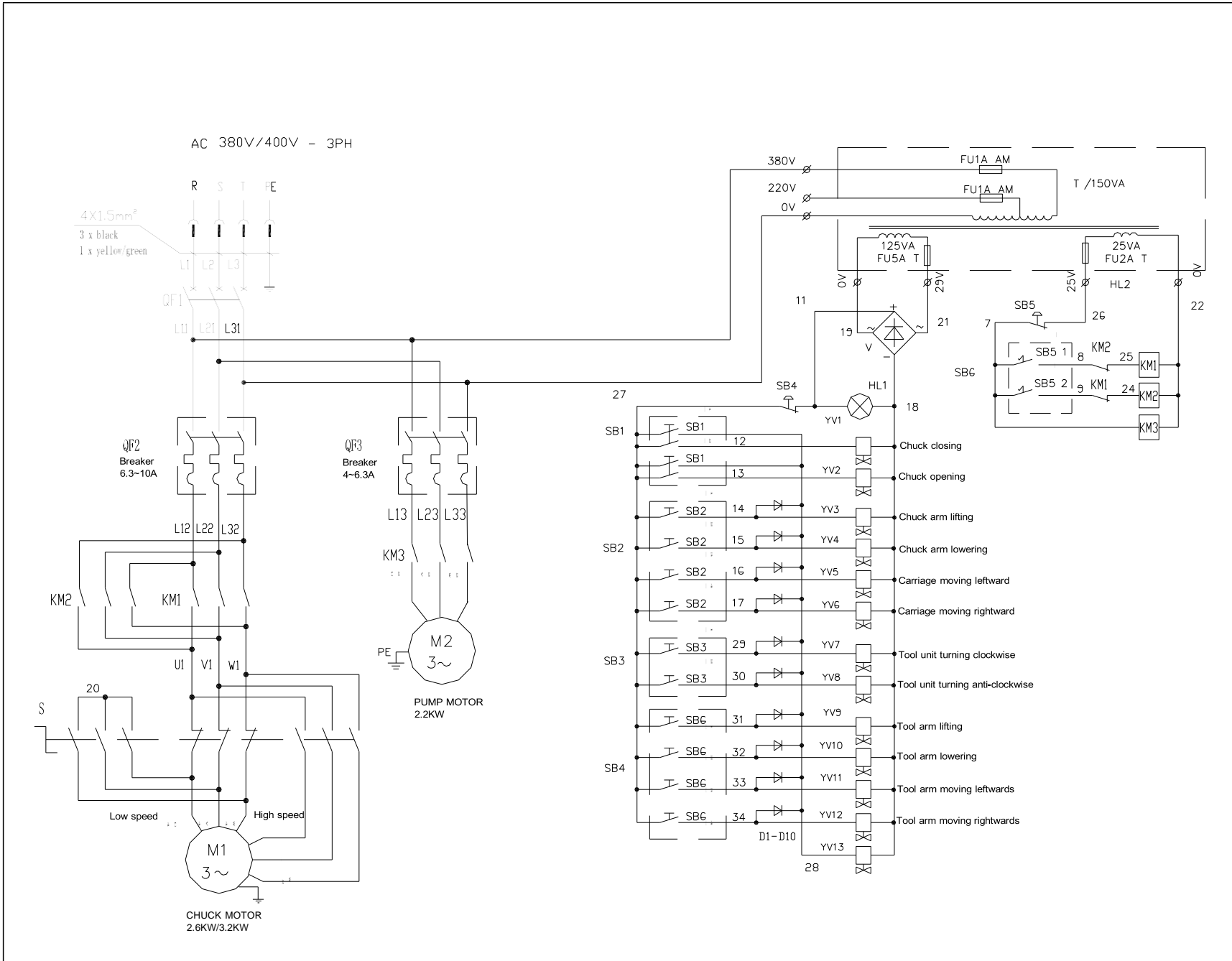

ЕЛЕКТРИЧ ДІАГРАМ
380V/400V – 3PH

QF1	Power switch
QF2	Breaker – chuck motor
QF3	Breaker – pump motor
S	Selector – chuck speed
M1	Chuck motor
M2	Pump motor
KM1	Contactora AC – chuck clockwise rotation
KM2	Contactora AC – chuck anticlockwise rotation
KM3	Contactora AC – hydraulic motor protection
SB1	Chuck switch
SB2	Joystick 1
SB3	Tool switch
SB4	Joystick 2
SB5	Emergency stop knob
SB6	Pedal switch
Y1	Solenoid valve – chuck closing
Y2	Solenoid valve – chuck opening
Y3	Solenoid valve – chuck arm lifting
Y4	Solenoid valve – chuck arm lowering
Y5	Solenoid valve – Carriage moving leftwards
Y6	Solenoid valve – Carriage moving rightwards
Y7	Solenoid valve – Tool arm turning clockwise
Y8	Solenoid valve – Tool arm turning anticlockwise
Y9	Solenoid valve – Tool arm lifting
Y10	Solenoid valve – Tool arm lowering
Y11	Solenoid valve – Tool arm moving leftwards
Y12	Solenoid valve – Tool arm moving rightwards
Y13	Circuit loading solenoid valve
HL1	Pilot lamp

UNI -TROL®

MANUFACTURING PLANT & STORE

<http://www.unitrol.com.pl>

UNI - TROL Co. Ltd.

ul . Estrady 56 , 01 - 932 Warsaw , Poland
tel.(+4822) 8179422 or 8349013 or 8349014 int. 117
fax(+4822) 8179422 or 8349013 or 8349014 int. 115
e-mail: office@unitrol.com.pl ; office@unitrol.pl

WHEEL BALANCING MACHINES RIM STRAIGHTENING MACHINES TYRE CHANGERS EQUIPMENT FOR TYRESHOPS

Statistic no. : 008132994 EC VAT no. : PL5270205246 Register no. : KRS 0000111731 EORI no. : PL527020524600000
Account : for EURO : ALIOR BANK SA for EURO: no. PL 96 2490 0005 0000 4600 4784 6179 (swift code: ALBPPLPW)



EC Declaration of Conformity

in accordance with directives : 2006/42/UE, 2014/35/UE and 2014/30/UE

We :

Uni-trol Co. Ltd.

Ul. Estrady 56

01-932 Warsaw

Poland

declare, under our exclusive responsibility, that the product:

Truck tyre changer

Electro-mechanical and hydraulic device

Type: MAXI-56,

Serial number

concerned by this declaration, complies with all relevant requirements of the Machinery Directive:

- **directive 2006/42/UE (safety machines),**

applicable in the essential requirements and relevant conformity assessment procedures, as well as on the essential requirements of the following directives:

- **directive 2014/35/UE (the low voltage);**

- **directive 2014/30/UE (the electromagnetic compatibility).**

The product also meets all relevant requirements of the Regulation of the Minister of Economy dtd 21.Oct. 2008 (Polish Dz. U. no. 199, item 1228) on the essential requirements for machines.

In order to verification of compliance with the applicable legal regulations have been consulted harmonized standards and other normative documents:

PN-EN ISO 12100:2012P

Safety of machinery -- General principles for design -- Risk assessment and risk reduction

PN-EN 61000-6-3:2008P

Electromagnetic compatibility (EMC) -- Part 6-3: General standards -- Emission standard for environments: residential, commercial and light industrial

PN-EN 61000-6-4:2008P

Electromagnetic compatibility (EMC) -- Part 6-4: General standards -- Emission standard for industrial environments

PN-EN ISO 13857:2010P

Safety of machinery - Safety distances to prevent hazard zones being reached by upper and lower limbs

PN-EN 349+A1:2010P

Safety of machinery - Minimum gaps to avoid crushing of parts of the human body

PN-EN 60204-1:2018P

Safety of machinery -- Electrical equipment of machines -- Part 1: General requirements

PN-EN 61293:2000P

Marking of electrical equipment with ratings related to electrical supply -- Safety requirements

PN-EN ISO 4413:2011E

Hydraulic fluid power - General rules and safety requirements for systems and their components

PN-EN ISO 11201:2012P

Acoustics -- Noise emitted by machinery and equipment -- Determination of emission sound pressure levels at a work station and at other specified positions in an essentially free field over a reflecting plane with negligible environmental corrections

PN-EN ISO 11202:2012P

Acoustics -- Noise emitted by machinery and equipment -- Determination of emission sound pressure levels at a work

station and at other specified positions applying approximate environmental corrections

PN-EN ISO 4871:2012P

Acoustics -- Declaration and verification of noise emission values of machinery and equipment

PN-EN 50419:2008P

Marking of electrical and electronic equipment in accordance with Article 11 (2) of Directive 2002/96/CE (WEEE)

The technical documentation of this device, referred to in point 1 of Annex VII A of the Machinery Directive, is located in the headquarters Uni-trol Ltd. (address as above) and will be made available to the competent national authorities for at least 10 years after the last piece.

The person responsible for the preparation of the technical documentation of the product and introducing changes in it, is MSc. Gregory Tworek - Member of the Board.

This EC Declaration of Conformity will be kept by the manufacturer of the product for 10 years from the date of produce the last unit and will available for market supervisory authorities for verification.

MSc. Gregory Tworek -
Member of the Board.

Warsaw, 30.10.2019

.....
Signature