

CE

УНГ - ТРОЛ

JANKA



OPERATING INSTRUCTION

UNI-TROL

**Computer Balancing Machines
Diagnostic Equipment
Workshop Equipment**

UNI-TROL Co. Ltd.

**MANUFACTURING PLANT & STORE
ul . Estrady 56 , 01 - 932 Warsaw
POLAND**

tel . / fax (+48 22) 8179422

tel . / fax (+48 22) 8349013 or 8349014

Production Plant - Sales Showroom - Factory Maintenance

1 GENERAL

Tyre fitting / removal machine *JANKA* is designed for fitting / removal of tubed and tubeless tyres on wheels of cars and vans. It may also be used for light - alloy wheels as its working parts do not distort the delicate structure of such wheels.

***JANKA* is capable of performing the following functions:**

Basic version:

- separation of tyre from wheel rim
- tyre removal and fitting
- inflation by means of an air - gun with pressure gauge

Extended version - additionally:

- surge inflation of tubeless tyres

TECHNICAL DATA :

- | | |
|------------------------------|--------------------------------|
| - tyre diameter range | - to 23 inches |
| - max tyre width | - 12 inches |
| - wheel clamping on machine | - pneumatic |
| - column deflection | - pneumatic |
| - supply air working | - from 0,8 to 1,0 MPa |
| - power supply | - 3 x 380V / 50Hz (+10%, -15%) |
| - power input | - 0,8 kVA |
| - motor rating | - 0,75 kW |
| - separator pressure on tyre | - 1,5 tonnes (at 1 MPa) |
| - required floor space | - 800 x 900 mm |
| - machine height | - 1450 mm |
| - machine weight | - ok. 180 kg |

2. INSTALLATION

1. Set up machine on a hard, flat base
2. Connect supply cable to 3x380V/50Hz socket.

NOTE:

The machine is provided with a four - core supply cable. Green - yellow wire, connected to machine housing is a protective wire.

Other three wires are phase wires.

NOTE:

The plug is not included in machine equipment. The user should procure a plug, suitable to the mains socket, installed in his workshop.

After connecting to the power supply, check the sense of rotation of the motor: after depressing table rotation pedal (item 19 fig 4) the worktable should rotate clockwise. If the table rotates anticlockwise interchange two phase wires in the plug.

3. Connect compressed air hose to supply coupling (item 1 fig 1). Use pneumatic hose min. 1 MPa working pressure, 8 mm inside diameter. Check whether oiler 5 is filled with oil.

NOTE:

Top - up compressed air lubricator with oil periodically (item 5 fig 1). In lubricator lid two screws can be seen; the smaller one is used for adjusting lubrication rate the larger one closes oil filler, through which oil may be injected with a syringe. The transparent reservoir may also be carefully unscrewed from the lubricator body and filled directly with oil. Use mineral oils, free of water and acids, 2 to 4 Engler viscosity (at 50 degrees cent.). HL 32 hydraulic oil is recommended. Air filter - water separator is maintenance - free - it is self - cleaning.

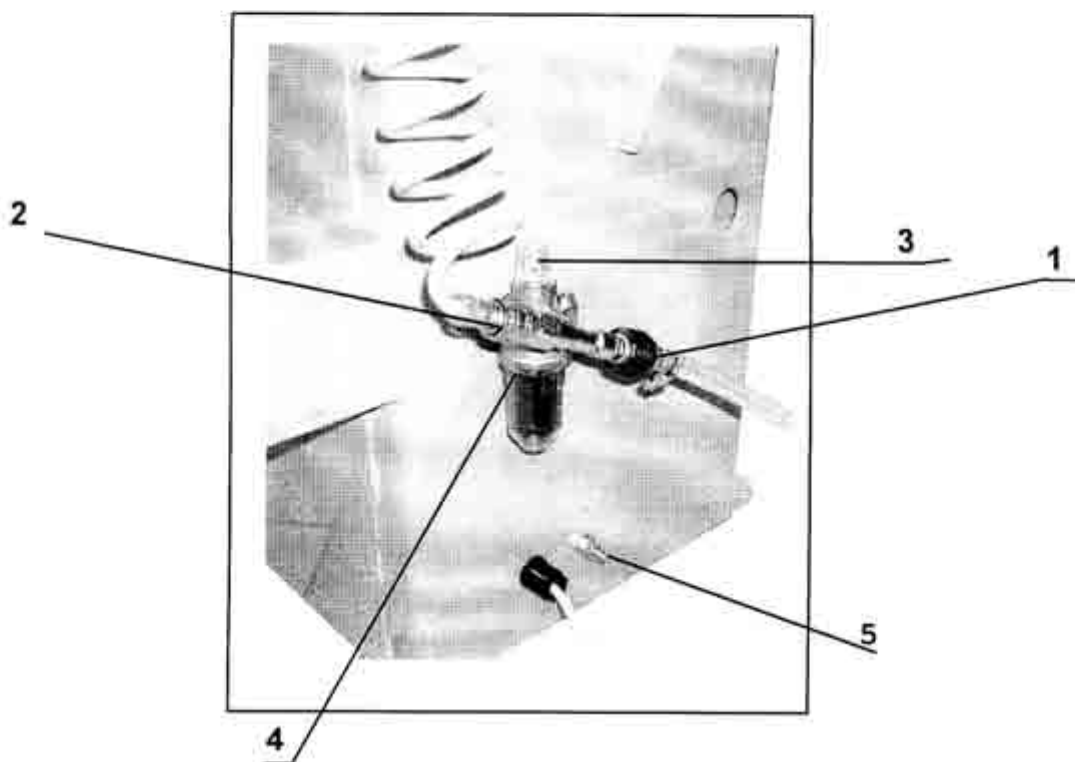

Fig. 1. Connections

1- supply coupling, 2- inflating coupling, 3- extra air outlet (to be used by the customer),
4- compressed air lubricator, 5- extra electric protective terminal

3. DESCRIPTION

Tyre changer JANKA is provided with an electropneumatic drive. Separation of tyre from wheelrim, column deflection, clamping the wheel on the worktable, locking the slide and arm with foot in working position is performed by means of pneumatic actuators. The worktable is rotated by means of an electric motor. Major machine units are shown in figs. 2, 3, 4, and 5.

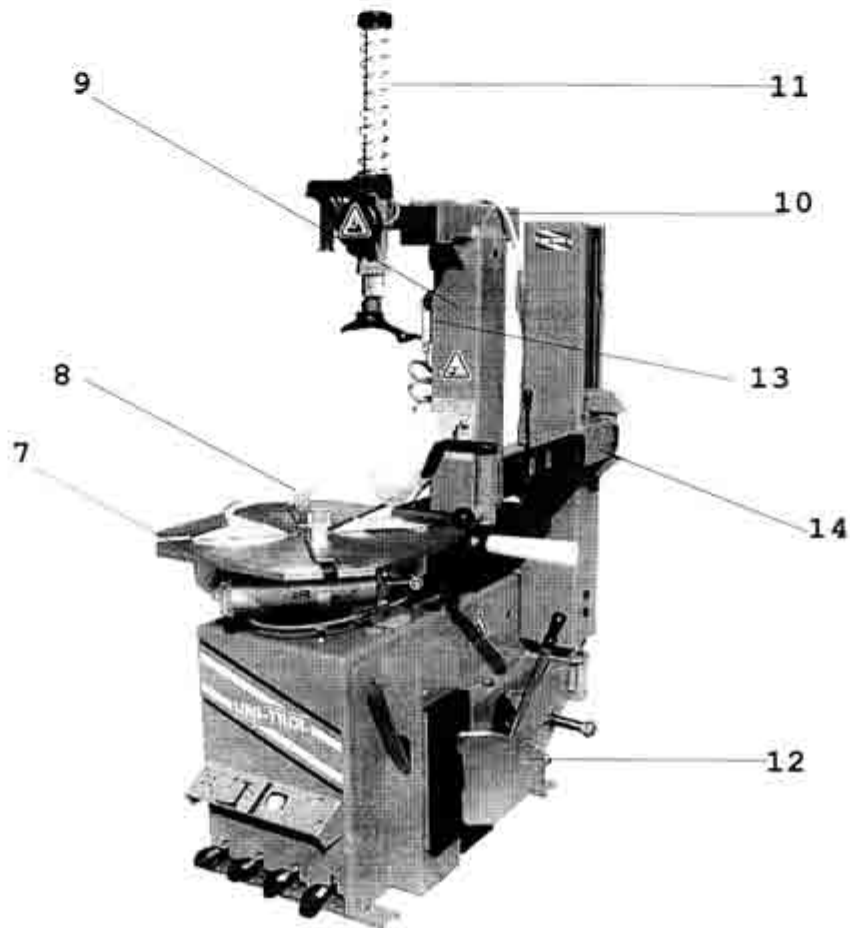

Fig 2 Major machine units

7- worktable, 8- table jaws, 9- column, 10- slide, 11- arm,
12- tyre separator, 13- tyre inflation gun, 14-

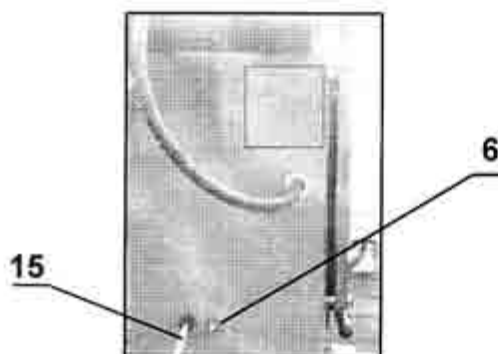

Fig. 3 View of the back wall

6- extra protective terminal,
15- supply table

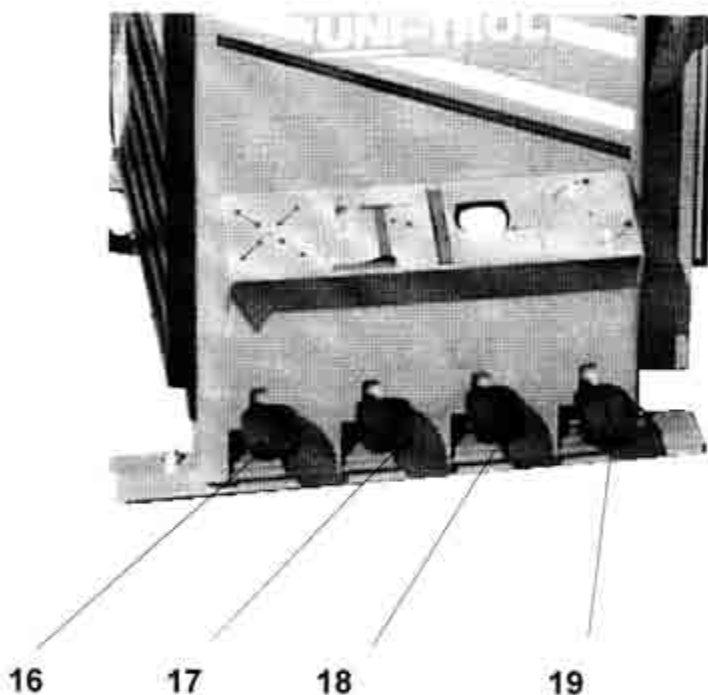

Fig 4 Control pedals

Wheel clamping pedals (item.16)

Controls onward and inward movement of jaws of the worktable. It has three working positions:

1- top position - jaws closed (shifted towards table centre)

2- mid position - shifting jaws outwards, yo any distance.

How to operate pedal in mid position:

- press pedal gently until a click is heard

- remove your foot to lock pedal in mid position

- subsequent pression of pedal will stopjaw movements. Press pedal gently to avoid its shifting to bottom position.

3- bottom position - full outward travel of jaws. Subsequent pression of pedal shifts it into top position.

Column deflection pedal (item.17)

Has three working positions:

1- top position - column in working position (verticale)

2- mid position - backward deflection of column to any distance .

how to operatethe pedal in mid position:

- press pedal gently until click is heard

- remove your foot to lock pedal in mid position

- susequent pression of pedal will result in deflection of column and release of the pedal will stop the movement. Press pedal gently to avoid its shifting to bottom position.

3- bottom position - max backward deflection of column. Subsequent depression of pedal shifts it to top position 9 moves column to the vertical).

Tyre separator pedal (item.18)

Has two working positions:

- 1- top position (initial position) - separator disengaged
- 2- depressing the pedal engages the separators, release of pedal disengages separator.

Worktable rotation pedal (item.19)

Has three working position:

- 1- mid position (initial) - table drive disengaged
- 2- pressing the pedal engages clockwise rotation of table (operating rotation), release of pedal disengages rotation.
- 3- lifting the pedal with your foot from mid position engages anticlockwise rotation of table 9 emegency rotation) release of pedal disengages rotation

Slide locking knob (item.20)

Turning the knob from its initial position to the left locks the slide and arm with foot in operating position. Turning the knob to the left unlocks the slide and throws the arm with foot upwards.

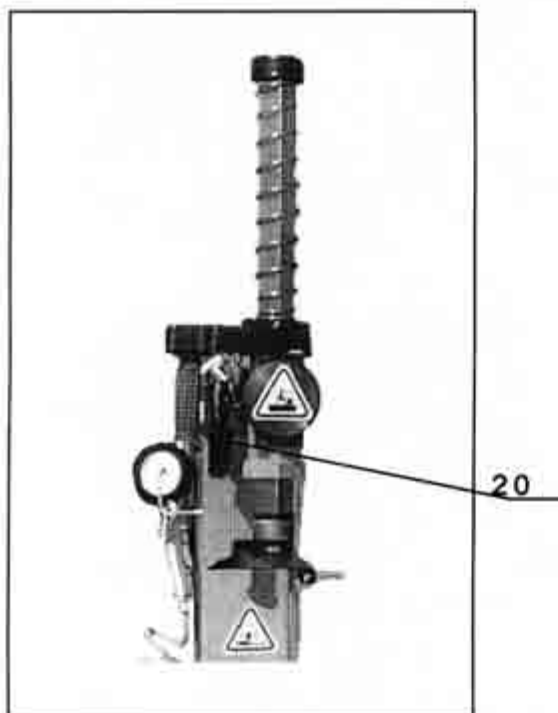

20- arm and slide locking knob

Fig. 5. View of working head

4. DEMOUNTING TYRE

Switch machine and air supply on.

Pull tyre separator lever 21 back, insert wheel between separator arm and rubber cushion on machine wall and move the arm to touch the tyre, close to wheel rim edge.

BE CAREFUL NOT TO REST THE ARM AGAINST WHEEL RIM

Holding separator arm in appropriate position, depress tyre separator pedal 18 and hold it until the tyre is separated from wheel edge. If necessary, repeat the operation at several points of wheel circumference. Then reverse wheel and separate in the same way tyre from wheel rim on the other side of the wheel.

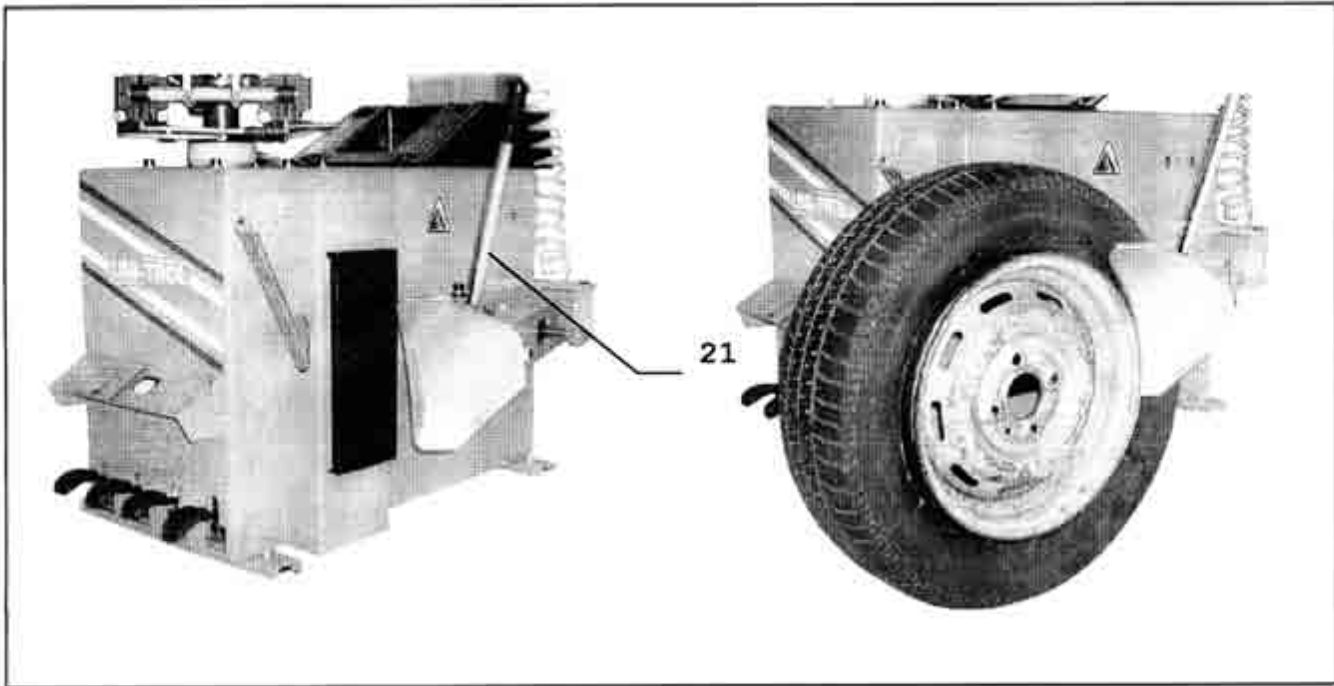

Fig 6. Separating the tyre
21- tyre separator lever

By means pedal 17, deflect column backwards. With pedal 16 open table jaws (pedal in mid and bottom positions). Set - up wheel on work table so that the tyre rests against jaws and shift pedal 16 to top position. Check if jaw hitches gripped wheel rim edge securely. Shift pedal 17 to top position - the column will revert to the vertical (working position). Grip, with your left hand, the top of lever 11 and with your right hand, the slide locking knob 20. Sliding the slide out, to an appropriate distance and pressing the arm top, make the foot rest on the wheel rim edge, as in fig 9. Then turn knob 20 to the right arm and slide will be loaded and the foot will automatically adopt the working position, taking into account the necessary clearance between the foot and the wheel rim. Press tyre edge, opposite to the foot into wheel rim recess. Rest tyre lever against the support of foot 22 and pull tyre edge on bulb 23 - as in figs 10 and 11.

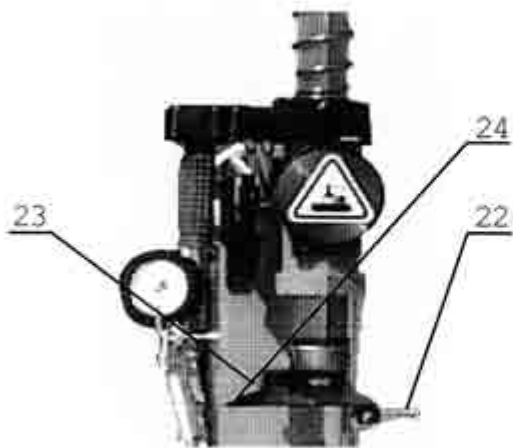

Fig. 7. Foot parts: 22- support, 23- bulb, 24- shoe

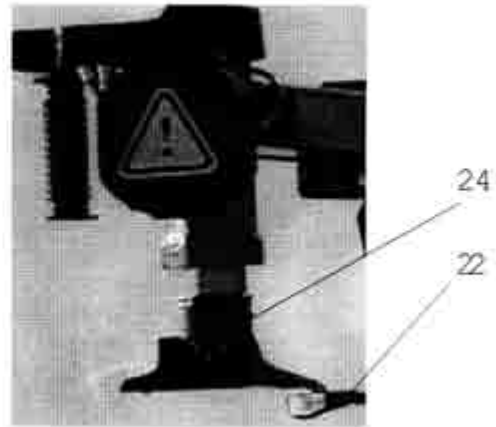

Fig. 8 Setting working head



Fig. 9. Foot in operating position



Fig. 10 Pulling tyre edge onto shoe



Fig. 11 Removing tyre

Bottom tyre edge is removed from the wheel rim without changing wheel clamping or foot position. Remove only the tube, push tyre edge opposite the foot into wheel rim recess from underneath and repeat tyre removal operation, as described above.

Unlock arm and slide with knob 20.

Deflect column backwards with pedal 17.

Open worktable jaws with pedal 16 and remove wheel rim from machine.

5. MOUNTING TYRE

Deflect column backwards with pedal 17. With pedal 16 open table jaws (pedal in mid or bottom position). Set - up wheel on worktable and shift pedal 16 to top position. Check whether jaw hitches gripped wheel rim edge securely. Shift pedal 17 to top position - the column will return to vertical (operating position).

Grip with your left hand the top of lever 11 and with your right hand - the slide locking knob 20. By moving slide outwards to an appropriate distance and pressing the top of the arm, bring the foot to rest against wheel rim edge, as shown in fig 9. Then turn knob 20 to the right - the arm and slide will lock and the foot will automatically adopt operating position, taking into account the necessary clearance between foot and wheel rim.

Place tyre on wheel rim.

Push bottom tyre edge, opposite the foot into wheel rim recess. Put opposite tyre edge on foot slide 24 and push under roller 23 - as shown in fig. 12.



Fig.12. Mounting Tyre

Depressing pedal 19, rotate worktable clockwise until bottom tyre edge is placed on the wheel rim. Should problems occur during fitting the tyre, e.g. jamming, release pedal and then lift it with your foot.

Install tube.

Push top tyre edge opposite the foot into wheel rim recess and install top tyre edge on wheel rim, proceeding in the same way as for the bottom edge.

Inflate tyre means of air gun with pressure gauge or by means of automatic inflator (description how to operate the inflator will be found in the latter part of these instructions).

Unload arm and slide with knob 20.

Deflect column backwards with pedal 17

Open worktable jaws with pedal 16 and remove wheel from machine.

6. OPERATING CONSIDERATIONS

The worktable is driven by an electric motor through a worm gear, lubricated with Shell OMALAA oil 680. After 4000 h operation (excluding breaks), clean the gear and change oil.

8. WARRANTY

All repairs and adjustments are to be made by the manufacturer. Machine repairs during warranty period by user's own means will result in cancellation of warranty.

TABLE OF CONTENTS

1. General	page 3
2. Installation	page 3
3. Description	page 5
4. Demounting tyre	page 8
5. Mounting tyre	page 10
6. Operating considerations	page 11

WHEEL BALANCING MACHINES

TYRE CHANGERS

EQUIPMENTS FOR TYRESHOPS

Statistic number : 008132994

Tax number : 527 - 020 - 52 - 46

CE Conformity Declaration

in accordance with directives : 98/37/CE and 89/336/CEE

We : **Uni-trol Co. Ltd.**
Ul. Estrady 56
01-932 Warsaw
Poland

declare, under our exclusive responsibility, that the product

Tyre changer type **JANKA**

version standard

to which this declaration refers, is in conformity with the following provisions of law :

- directive 98/37/CE (the safety of machinery);
- directive 89/336/CEE and following modifications (the electromagnetic compatibility).

For verification of conformity with the provisions of law were consulted the harmonized standards or other norms documents :

- | | |
|----------------------------|---|
| - PN - EN 292 - 1 / 2000 | Basic concepts, general principles for design - Part 1; |
| - PN - EN 292 - 2 / 2000 | Basic concepts, general principles for design - Part 2; |
| - PN - EN 50081 - 1 / 1996 | Generic emission standard, residential, commercial and light industry; |
| - PN - EN 50081 - 2 / 1996 | Generic emission standard, industrial environment; |
| - PN - EN 50082 - 1 / 1999 | Generic immunity standard, residential, commercial and light industry; |
| - PN - EN 50082 - 2 / 1997 | Generic immunity standard, industrial environment; |
| - PN - EN 294 / 1994 | Safety distances to prevent danger zones being reached by the upper limbs; |
| - PN - EN 349 / 1999 | Minimum gaps to avoid crushing of parts of the human body; |
| - PN - EN 61293 / 2000 | Marking electrical equipments with ratings to electrical supply - Safety requirements. |
| - 62 / 2002 | Electrical accesories; |
| - PN - EN 983 / 1999 | Safety of machinery - Safety requirements for fluid power systems and their components - Pneumatics |

This declaration is valid for all products which are produced in accordance with the technical documentation which is part of this declaration.

Warsaw, 01.05.2004

"UNI - TROL" Sp. z o.o.
ul. Estrady 56, 01-932 Warszawa
tel. (0-22) 817-94-13, 834-90-14
tel. (0-22) 817-94-22
NIP 527-020-52-46

Wiesław Roguski
Chairman of Board

Signature

WHEEL BALANCING MACHINES

TYRE CHANGERS

EQUIPMENTS FOR TYRESHOPS

Statistic number : 008132994

Tax number : 527 - 020 - 52 - 46

CE Conformity Declaration

in accordance with directives : 98/37/CE and 89/336/CEE

We : **Uni-trol Co. Ltd.**
Ul. Estrady 56
01-932 Warsaw
Poland

declare, under our exclusive responsibility, that the product

Tyre changer type **JANKA K**

version standard

to which this declaration refers, is in conformity with the following provisions of law :

- directive 98/37/CE (the safety of machinery);
- directive 89/336/CEE and following modifications (the electromagnetic compatibility).

For verification of conformity with the provisions of law were consulted the harmonized standards or other norms documents :

- | | |
|----------------------------|---|
| - PN - EN 292 - 1 / 2000 | Basic concepts, general principles for design - Part 1; |
| - PN - EN 292 - 2 / 2000 | Basic concepts, general principles for design - Part 2; |
| - PN - EN 50081 - 1 / 1996 | Generic emission standard, residential, commercial and light industry; |
| - PN - EN 50081 - 2 / 1996 | Generic emission standard, industrial environment; |
| - PN - EN 50082 - 1 / 1999 | Generic immunity standard, residential, commercial and light industry; |
| - PN - EN 50082 - 2 / 1997 | Generic immunity standard, industrial environment; |
| - PN - EN 294 / 1994 | Safety distances to prevent danger zones being reached by the upper limbs; |
| - PN - EN 349 / 1999 | Minimum gaps to avoid crushing of parts of the human body; |
| - PN - EN 61293 / 2000 | Marking electrical equipments with ratings to electrical supply - Safety requirements. |
| - 62 / 2002 | Electrical accessories; |
| - PN - EN 983 / 1999 | Safety of machinery - Safety requirements for fluid power systems and their components - Pneumatics |

This declaration is valid for all products which are produced in accordance with the technical documentation which is part of this declaration.

Warsaw, 01.05.2004

"UNI - TROL" Sp. z o.o.
ul. Estrady 56, 01-932 Warszawa
tel. / fax (+48 22) 834-90-13, 834-90-14
tel. (0-22) 817-94-22
NIP 527-020-52-46

Wiesław Roguski
Chairman of Board

Signature