

WWW.UNITROL.PL

UNI-TROL
GARAGE EQUIPMENT



OPERATING MANUAL

WHEEL BALANCING MACHINE FOR CARS

2451USG / 2451L / 2451LP / 24/7



Wheel balancing machine for cars
Model 2451 USG
Model 2451 L
Model 2451 LP (with pneumatic clamp)
Model 24/7

Serial number

Production date

MANUFACTURER

UNI-TROL Sp. z o.o.
ul. Estrady 56, 01-932 Warszawa
tel./fax (22) 834-90-13...14, (22) 817-94-22
NIP 527-020-52-46

AUTHORISED SERVICE

UNI-TROL Sp. z o.o. - SERVICE
ul. Estrady 56, 01-932 Warszawa
tel./fax (22) 834-90-13...14, (22) 817-94-22 **[134]**
serwis@unitrol.pl

The manufacturer reserves the right to make changes in the machine to improve its operation without the need to amend this manual.

TABLE OF CONTENT

INTRODUCTION.....	4
GENERAL SAFETY REGULATIONS.....	5
PACKING, TRANSPORTATION, STORAGE	6
NAMEPLATE	8
TECHNICAL SPECIFICATION	9
MACHINE DESCRIPTION.....	10
SAFETY.....	12
MAINTENANCE AND SCRAPPING OF BALANCING MACHINE	14
INSTALLATION	16
SPIKE HOLDER MOUNTING.....	20
MOTORCYCLE WHEELS HOLDER MOUNTING	21
WHEEL MOUNTING	22
CAR WHEEL ON SPIKE HOLDER.....	25
MOTORCYCLE WHEEL	26
MASHINE OPERATION.....	27
MASHINE SCREENS DESCRIPTION.....	28
MAIN MENU.....	28
UNBALANCE MEASUREMENT	29
PROGRAM 3P – HIDDEN WEIGHT	34
OPTIMIZATION	37
CALIBRATION.....	40
SETTINGS.....	42
PRINTING	47
MAINTENANCE AND SERVICE	50
FAULT CAUSES AND THEIR ELIMINATION.....	50
SCRAPPING.....	50
CONFORMITY CERTIFICARTE CE.....	51

INTRODUCTION

Dear Customer,

This operator's manual is intended to familiarize the operator with the most important principles of use, safe operation and maintenance of the Wheel balancers 2451USG, 2451L, 2451LP, 24/7.

Lifting, transport, unpacking, assembly, installation, basic maintenance - these activities do not require the presence of a service technician, but must be performed with particular care and attention. The manufacturer declines all responsibility for injuries to persons or damage to vehicles or other objects if any of the above operations is performed contrary to the operating instructions or if the machine has been used improperly.

The manufacturer reserves the right to make any changes, both material and construction, at any time, in order to increase the durability and functionality of the product.

The "UNI-TROL" company is responsible for the information provided in this manual.

If there are factual errors or editorial mistakes, they will be corrected in subsequent editions.

This publication may not be reproduced in full or in any part without the authorization of the manufacturer.

GENERAL SAFETY REGULATIONS

Failure to follow the recommendations and working methods listed here, and to ignore the warnings may result in serious injury to the operator or others. Do not turn on the device until you have thoroughly read this manual and all the information contained in it, relating to safe operation.

The machine may only be operated by qualified and authorized personnel. A qualified operator is a person who has carefully read the manual, has undergone appropriate training and has knowledge of machine's safety, operation and adjustment. It is forbidden to operate the machine by persons under the influence of alcohol or drugs that impair their physical or mental abilities. However, if the prescribing physician sees no contraindications, the operator can operate the machine. The following conditions must be respected:

- The operator must be able to read and understand all information contained in this manual.
- The operator must have full knowledge of the operation and characteristics of the machine.
- Unauthorized persons should keep a safe distance from the operating device.
- The device must be installed in accordance with the applicable regulations and standards.
- All persons operating the machine must be properly trained, follow the correct working methods and be properly supervised at work.
- It is not allowed to leave nuts, bolts, tools and other objects loose on the device as they may get caught between moving parts during device operation.
- Do not touch electric wires, inside motors or other electrical devices, unless the power has been previously turned off and there is no visible break in the power supply circuit of the device.
- Please read this manual carefully to ensure correct and safe operation of the device.
- This manual should be kept near the machine, in a place accessible to the operator, to enable possible verification of information or clarification of doubts concerning its operation.
- During maintenance, the general rules for the prevention of accidents in industry relating to high voltage equipment must be followed.
- Any unauthorized modifications to the device automatically relieve the manufacturer from any liability in the event of damage or accident that may be related to the modifications made. In particular, this applies to dismantling or tampering with the safety devices used in the device, which is a violation of the accident prevention regulations in industry.



ATTENTION: Do not remove safety and operating signs from the machine. Immediately attach or replace missing or illegible warning and information plates. Replacement plates are available at the UNI-TROL Production Plant.

PACKING, TRANSPORTATION AND STORAGE



ATTENTION: All operations concerning packing, lifting, moving, transporting and unpacking must be carried out by qualified personnel only.

Packing

The balancing machine is sent as a complete piece of equipment (quick change holder, balancing machine, protective hood, operating manual). The balancing machine can be packed in a few different ways:

- pallet + stretch foil + carton box
- pallet + stretch foil
- pallet + carton box

Transport

The package can be lifted or displaced by fork-lift or pallet trucks. Once the cargo arrives at its destination, it is recommended to check if its contents have not been damaged during transportation. It is also recommended to check the conformity of the delivery with its bill of landing. In case of non-conformity or transportation damages it is necessary to inform without delay the responsible person or carrier about it. Moreover, the loading should be done with extreme precautions and consideration.

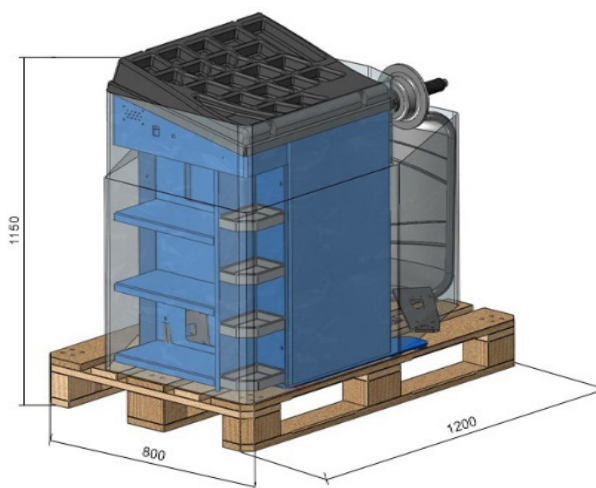
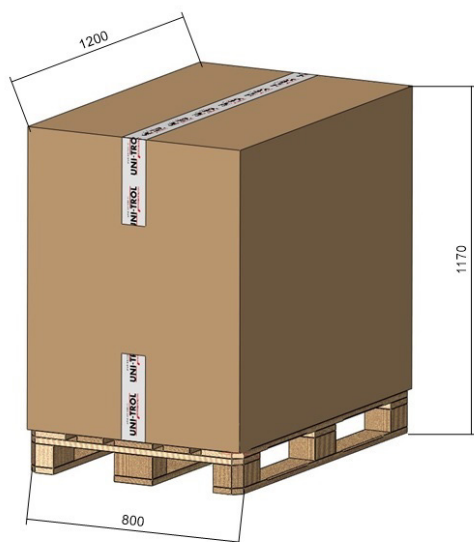

Package height with carton box: 1170 mm (without: 1150 mm)

Package weight: 800 mm

Package depth: 1200 mm

Storage

The machine should be stored in a dry room free of dust.

INSTALLATION

Be especially careful when unpacking, assembling and preparing the device for operation. Failure to follow the work procedures outlined here may result in damage to the equipment and injury to the operator and others.

Unpack the machine and check that the machine has not been damaged during transport. If the machine is on a pallet, in order to move the device, insert the forks of the forklift into the slots of the pallet on which the device is placed. The place of installation of the device must strictly comply with the requirements of work safety regulations. The device connected to the electric and pneumatic systems must not be moved.

Environmental conditions for the workplace of the device

- Relative humidity from 30% to 60%,
- Temperature from 0 ° C to 55 ° C.





ATTENTION: The machine must not be used in an explosive environment.

At a relative humidity above 60%, condensation may occur on the electronic components of the machine. It may cause its faster wear (corrosion) or damage (short circuit). If you suspect that the machine is working in conditions of increased relative humidity, it is recommended to use a heating plate, which can be additionally purchased at Uni-Trol.

NAMEPLATE

When contacting our authorized service, providing the model and serial number aids in getting help from service Staff and quickens the process of sending spare parts.
For convenience and clarity, a table is presented below. If any differences between the table below and the name plate on the machine, data on the name plate apply.

 www.unitrol.pl	<p>Uni-trol Sp. z o.o. ul. Estrady 56, 01-932 Warszawa Zakład Produkcyjny - Serwis – - Salon Sprzedaży ☎/📠 +48 22 8179422 e-mail: office@unitrol.pl</p>
<p>Wheel balancing machine 24/7</p>	
<p>Technical data :</p>	
- elektric supply	230 V / 50 Hz
- pneumatic supply	od 8 do 10 bar
- motor power	80 W
- noise level	< 67 dB
- avarage noise level	< 65 dBA
- weight netto	approx. 100 kg
<p>Serial number:</p> <p style="text-align: center; font-size: 1.2em;">138/10</p>	 
<p>Made in Poland</p>	

TECHNICAL SPECIFICATION

Wheel diameter	10"-30"
Rim width	2"-15"
Balance accuracy	0,1g
Imbalance position accuracy	0,9°
Measuring time	7s
Max. Wheel weight	60kg
Motor power	80W
Rotation speed	160 rpm
Wheel balancer dimensions:	
Without hood, monitor	1000 x 580 x 900 mm
With monitor, hood closed	1170 x 850 x 1260 mm
With monitor, hood open	1170 x 1000 x 1450 mm
Weight	Approx. 100 kg
Electric power	230V/50Hz
Average noise level L _{SR}	65 dBA

MACHINE DESCRIPTION

The 2451USG / 2451L / 2451LP / 24/7 balancing machine is designed for dynamic balancing of car and van wheels in one measurement run. The original solutions ensure safety, simplicity and ease of machine operation, its high reliability and a short time of wheel balancing.

Balancer components:

- main module in a housing with a cover and a set of accessories,
- wheel cover,
- LCD monitor (optional touchscreen),
- manual (2451USG / 2451L / 24/7) or pneumatic (2451LP) clamp,
- laser printer (optional).

The balancing machine :

- has modern measuring system with computer data processing ensures high accuracy and measurement speed,
- operates any wheels, including light alloy rims, with all types of weights, both clipped-on and taped-on,
- sets the balancing accuracy according to the balanced wheel quality and weight,
- operates with special holders which allow efficient mounting of most of the wheels,
- has calibration system, allowing the user to adjust the machine measuring system to his own in case of suspicion of incorrect place and/or size unbalance indication,
- has "hidden weight" function,
- can optimize the tyre alignment relatively to the rim in order to reduce its imbalances,
- generates voice messages,
- has the function of counting saved weights.

When purchasing a balancing machine with a touch screen (option), the machine is additionally operated by touching the screen.

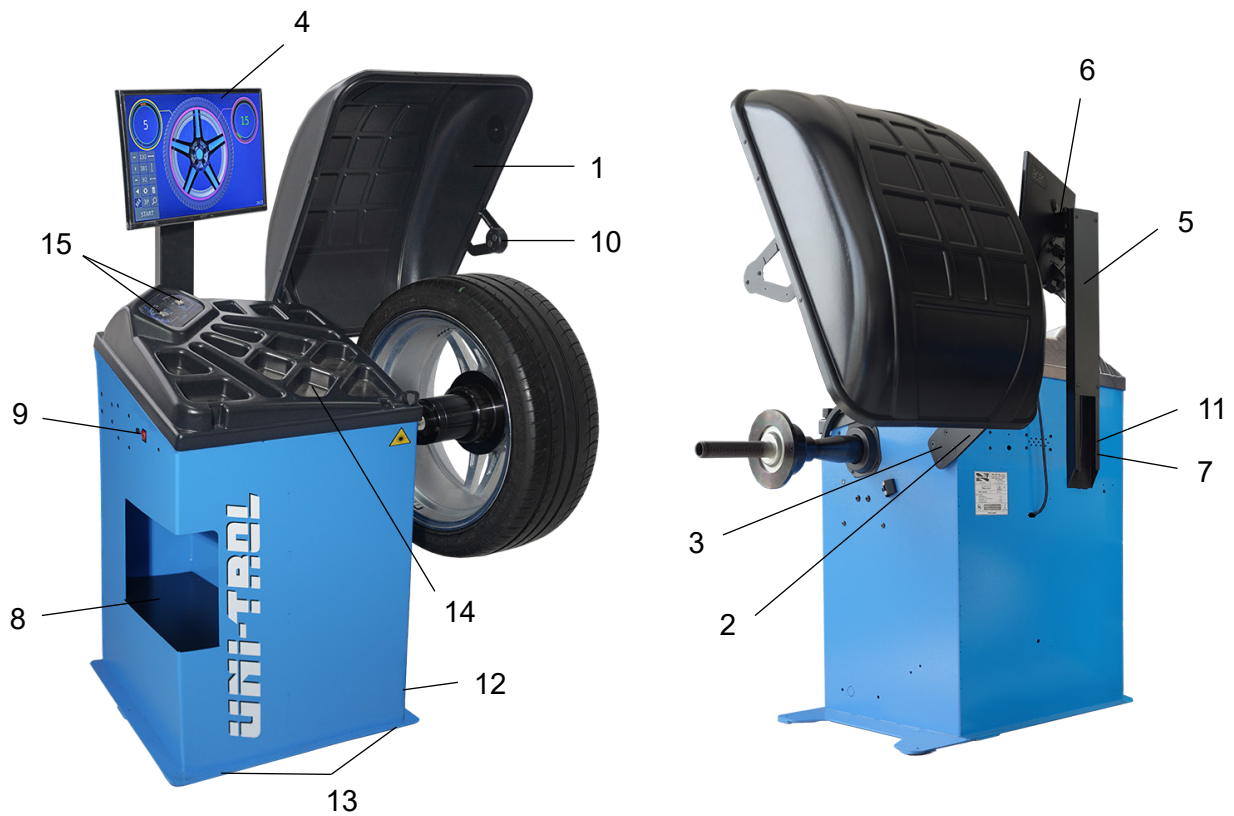

Fig. 1: Wheel balancer components

- 1 - wheel hood
- 2 - hood holder
- 3 - hood axis collar (behind hood holder)
- 4 - monitor
- 5 - monitor's bracket
- 6 - monitor's tilt regulator
- 7 - power cable outlet
- 8 - shelf
- 9 - main switch
- 10 - ultrasonic sensor
- 11 - USB panel
- 12 - pneumatic clamp pedal (option)
- 13 - rubber pads
- 14 - tools tray
- 15 - control buttons

SAFETY



WARNING: This chapter should be read carefully because it contains important information for operators and other persons concerning hazards of using the balancing machine in an inappropriate way.

Below are explanations concerning hazards and risks which can occur during balancing machine operating and maintenance. General and detailed precautions are given for avoiding potential hazards.



Warning: The TROLL 2351 balancing machine was designed for the balancing of car and motorcycle wheels in one measurement cycle. Any work with the balancing machine should be preceded by comprehensive reading and understanding of this manual. Any other type of usage of this balancing machine is not allowed. In particular, the balancing machine is not intended for balancing other elements or balancing truck wheels.



ATTENTION: The producer and the dealer do not bear any responsibility for personnel injuries or vehicle and other objects' damages in case of improper or unauthorized use of the balancing machine.

Any operation of the balancing machine is not allowed without prior closing of the hood. Not satisfying the above mentioned recommendations can result in serious human injuries and irreparable balancing machine's damages and wheel damages.

General precautions

It is required that the operator and the maintenance technician adapt safety rules obligatory in the country of installation. Moreover, the operator and the maintenance staff should read all the information regarding safety placed on the machine and all the information included in this manual.

Risk of electric shock – hazard of electric shock can occur in those balancing machine areas, where electric cables are placed. Use of water sprayers, vapour sprayers (high pressure washing units), dissolvers and painting equipment is not allowed in vicinity of the balancing machine and in particular they should not be in contact with the control unit.

Impact risk – during operation of the machine here is a risk of some parts of the balancing machine hitting the operator. With the protective screen open, personnel must preserve all precautions to avoid hitting against machine parts.

Risk of wheel easing – before balancing starts, one should check if the wheel is properly and firmly fixed in its holder.



ATTENTION: It is forbidden to unscrew the wheel during machine work!
It is forbidden to leave the machine unattended during work!
It is forbidden to use wheels exceeding the maximum wheel weight!
It is forbidden to initiate a measurement with an incorrectly mounted wheel!

Skid risk – this hazard can be caused by floor contamination with grease in the proximity of the balancing machine. The area under the balancing machine, the holders and the area near them must be kept clean at all times. All the oil spots should be removed instantly.

Hazard caused by poor illumination – the operator and the maintenance technician must have the possibility to check if all areas of the balancing machine are properly and uniformly illuminated according to the regulations applied in the installation place.

Risk of balancing machine defect during work – to produce a reliable and safe balancing machine, the manufacturer applied suitable materials and manufacturing techniques that are necessary for this type of equipment. Nevertheless the balancing machine should be operated according to the producer's recommendations. Technical service (after warranty period) and other maintenance works described in chapter 4.1 "Maintenance" should be carried out with specified periodicity.



ATTENTION: All operations of the balancing machine contrary to its function can cause danger, serious damage or accidents to anybody near the machine. It is crucial to scrupulously observe all recommendations contained in this manual concerning maintenance and safety.

Risk involving machine's moving parts – During any kind of operations all limbs should be kept as far from moving parts as possible at all times. Necklaces, bracelets and loose clothes as well as long hair may cause potential danger to the operator. It is mandatory to take any jewellery off, wear clothes fit close to body and use headgear. The operator should use appropriate shoes to prevent any lower limb injuries.

MAINTENANCE AND SCRAPPING OF BALANCING MACHINE

Maintenance

Maintenance should be conducted by experienced personnel with knowledge concerning the principles of balancing machine's operation. During the maintenance process one should preserve all precautions in order to avoid any accidental start of the balancing machine. The master switch should be pushed out and its light should be off. One should also adhere to all instructions given in chapter 3.

Periodical maintenance

In order to keep the balancing machine in a good operational state one should observe the below mentioned indications:

- Clean your balancing machine at least once a month without using any chemical washing agents or high pressure spray guns.
- Check the operational state of all equipment periodically.
- Lubricate all holders periodically and keep them clean.
- Check the state of all cords once a year.



ATTENTION: Disregard of these recommendations will dismiss the manufacturer from any responsibility included in warranty.



WARNING: Always remove all dirt from the area near the balancing machine.

Machine scrapping



ATTENTION: During machine scrapping one should preserve all precautions described in chapter 3, also applied during assembly.

As well as assembly, disassembly has to be executed by trained personnel only. All metal parts should be utilized as metal scrap. In all cases of machine scrapping, the utilization of all materials has to be conducted according to the rules applied in the country of installation.

One should also notice that for tax purposes, effective machine scrapping should be documented in reports and forms according to the rules applied in the installation country.

Fire protection

The machine does not constitute fire hazard. Nevertheless, room in which the balancing machine is installed, has to fulfil requirements of fire protection regulations applied in the country of installation.

Always keep one or more portable fire extinguishers within the operator's reach (operator zone), in order to prevent any fire hazard.

Accident prevention

During lifting/lowering, shifting, installing, assembling and disassembling of the balancing machine, one should preserve all precautions provided in regulations concerning accident prevention applied in the installation country. Moreover, all regulations concerning fork-lift trucks have to be preserved.

Safety designing provided in the balancing machine

The machine has been equipped with a hood, which protects the operator with revolving parts of the balancer. The machine has been designed in such manner as not to initiate a measurement by accident or start one with the hood opened.

Each measurement initiation has to be preceded with pressing the *START* button, which starts only a single measurement (assured by software). Due to many safety design constructs, it is impossible for the machine to initiate any kind of measurement sequence on its own.

If any other incidental situations not mentioned in this operating manual occur, the operator is to immediately stop working with the machine, call authorized service and describe the problem.

Noise evaluation

Noise emission approximations were conducted in ordinary surroundings for a wheel balancing machine using environmental correction, defined and simplified by norm PN-EN ISO 11202. Measurements were made using a 20" wheel, weight approximately 35kg and in correct working conditions, i.e. nominal power supply conditions.

Measurements using a calibrated microphone were performed during a period from start of measurement and reaching maximal rotation speed to turning the drive motor off and stopping the wheel completely. For evaluation purposes an average from a couple of maximised measurements has been taken.

Average level of acoustic pressure $L_{av} \leq 65$ dBA .

INSTALLATION

The following operations may be performed by persons who have previously been trained in the use of the device described in this manual. The following instructions must be carefully followed to prevent possible damage to the balancing machine or risk of injury to people. Make sure that there are no people other than the operator in the work area.

INSTALLATION REQUIREMENTS

The wheel balancer should be installed at a safe distance from walls, columns and other devices. The room must be previously equipped with an electric power source. The wheel balancer can be placed on any surface, provided that it is dry, even and hard. All parts must be uniformly illuminated with an intensity that ensures the safe performance of all the adjustment and maintenance operations specified in the manual. The presence of shaded areas, light reflections and blinding light is unacceptable. Any situation that might cause eye strain should be avoided. Lighting must be installed in accordance with the regulations in force at the place of installation (responsibility rests with the lighting contractor).



ATTENTION: The machine is equipped with two lasers used in the wheel balancing procedure. In their natural position, the lasers point downwards during operation and pose no risk to the operator's eyes. However, special care should be taken with any type of cleaning and maintenance work that may expose the eyes to the laser beam. Direct blinding of this beam may cause permanent eye damage.

Before installation unpack all parts and check that they have not been damaged. For maneuvering and lifting the machine see "Transport, Storage, Installation".



ATTENTION: The balancing machine must not be screwed to the ground! The openings in the lower part of the housing are for transport purposes only!

ELECTRIC SUPPLY SOURCE REQUIREMENTS

The balancing machine is powered from a single-phase 230V 50Hz alternating current network. The machine should be connected to the electric power supply through the appropriate plug and socket used in the place of installation and protected with a 30mA residual current circuit breaker. The machine's current consumption is structurally protected by a 2A slow-blow fuse.

INSTALLATION PLACE

The wheel balancer should be installed in a closed, dry interior, heated in the autumn and winter period. Relative air humidity should be 30-60% without condensation, and the ambient temperature 5-55 ° C. The ground intended for the foundation of the machine should be hard, solid and flat (preferably concrete). The balancer should be placed on three rubber pads provided with the machine, which should be placed under the flat feet welded to the base.

REQUIRED WORKING SPACE

The balancer dimensions determine its working area. Only trained and authorized operators are allowed in this area. The maximum working space requirements are 2870x3000 mm with a minimum distance from the walls as shown in Figure 2. The numbers 1 and 2 indicate the operator's workplace.

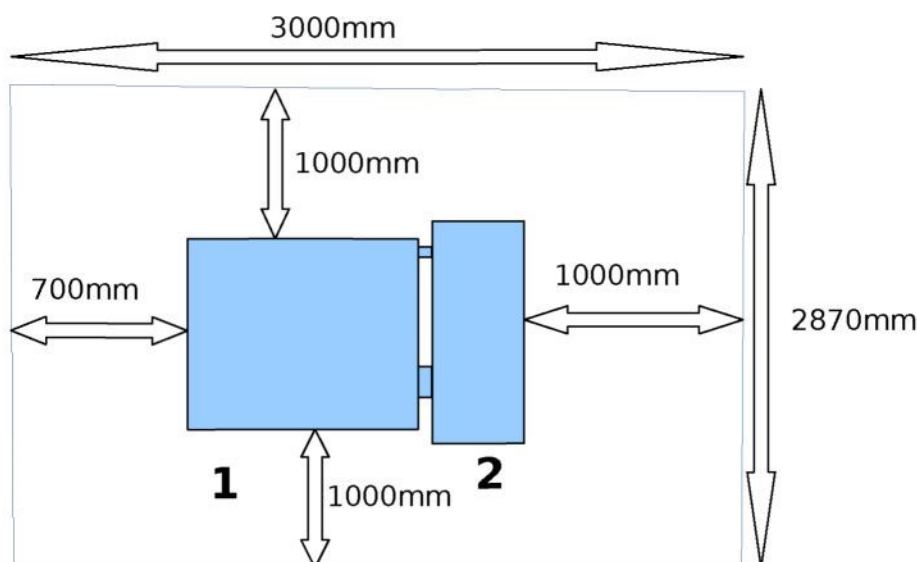

Fig. 2: Required working space

WHEEL HOOD MOUNTING

The description and the numbering of elements below are based on Figure 1.

- unscrew the bolts from the hood axle collar (3),
- holding the wheel hood (1) place it in such a position that the hood's holes (2) are aligned with the holes of the collar (3),
- Screw the hood (2) to the hood axle collar (3).

MONITOR MOUNTING AND CONNECTING

The description and the numbering of elements below are based on figure 1. To mount the monitor on the balancer first screw the monitor bracket (5) to the machine housing using 2 screws with wide washers. Put the monitor tilt regulator (6) on the bracket and then screw the monitor (4) to it. Finally, connect the power cable, signal cable and USB cable (in case of a touch-screen monitor).

WHEEL HOLDER MOUNTING



WARNING: The machine can be delivered with already mounted adapter.

The assembled quick-release holder for car/van rims with central mounting hole is shown in Figure 3.

Before installing the holder thoroughly clean the conical surfaces of the spindle and the holder (1, 2) with a cloth. Next, put the holder on the spindle so as to maintain the position of the markers (3) on the spindle pin and the holder as shown in figure 3. Finally tighten the holder to the spindle (4) with a screw.



ATTENTION: Careful conical surfaces cleaning and maintaining the right holder position relating to the spindle (overlapping marks) are important conditions for correct wheel balancing.

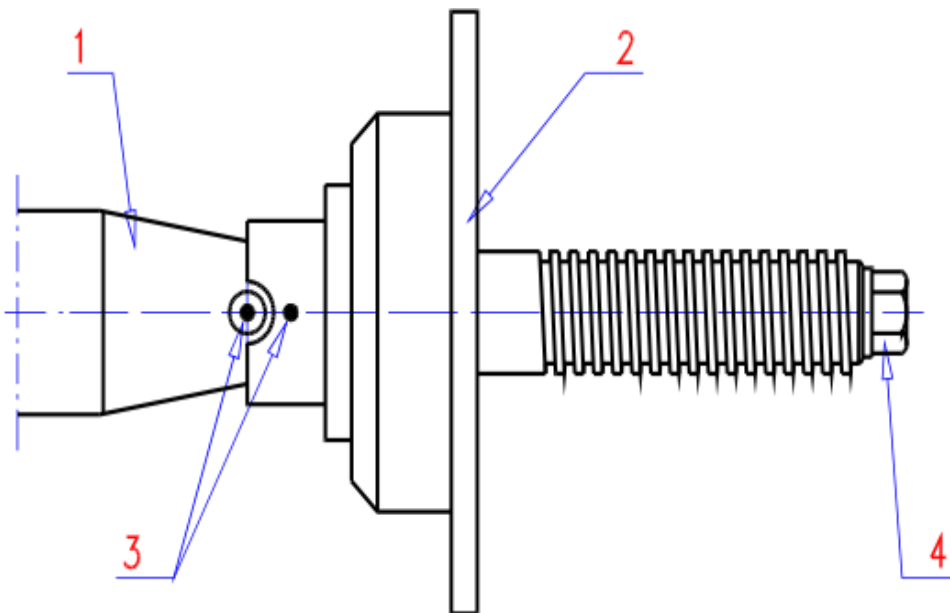

Fig. 3: Wheel Balancer holder without nut and cones



Fig 4: Holder elements:

- 1: holder with flange 2: clamping nut*
 - 3: holder mounting screw on spindle 4: spring 5: nut clamp*
 - 6: centering cone nr 1 7: centering cone nr 2 8: centering cone nr 3**
 - 9: centering cone nr 4* 10: centering cone nr 5 (110mm-125mm)**
 - 11: centering cone nr 6 (125mm-145mm)*, 12: centering cone nr 7 (145mm-165mm)**
- * - optional equipment*



Fig. 5: Clamping nut.

SPIKE HOLDER MOUNTING



ATTENTION: Spike holder is an optional equipment and not delivered with machine in its standard version.

A spike holder shown and described in Fig. 6 is used for mounting wheels without a central hole. It can be fitted with wheels with 3, 4, 5 and 6 holes.

Spike holder mounting depends on the balanced wheel that's why the whole process has been described in the section CAR WHEEL WITH SPIKE HOLDER.

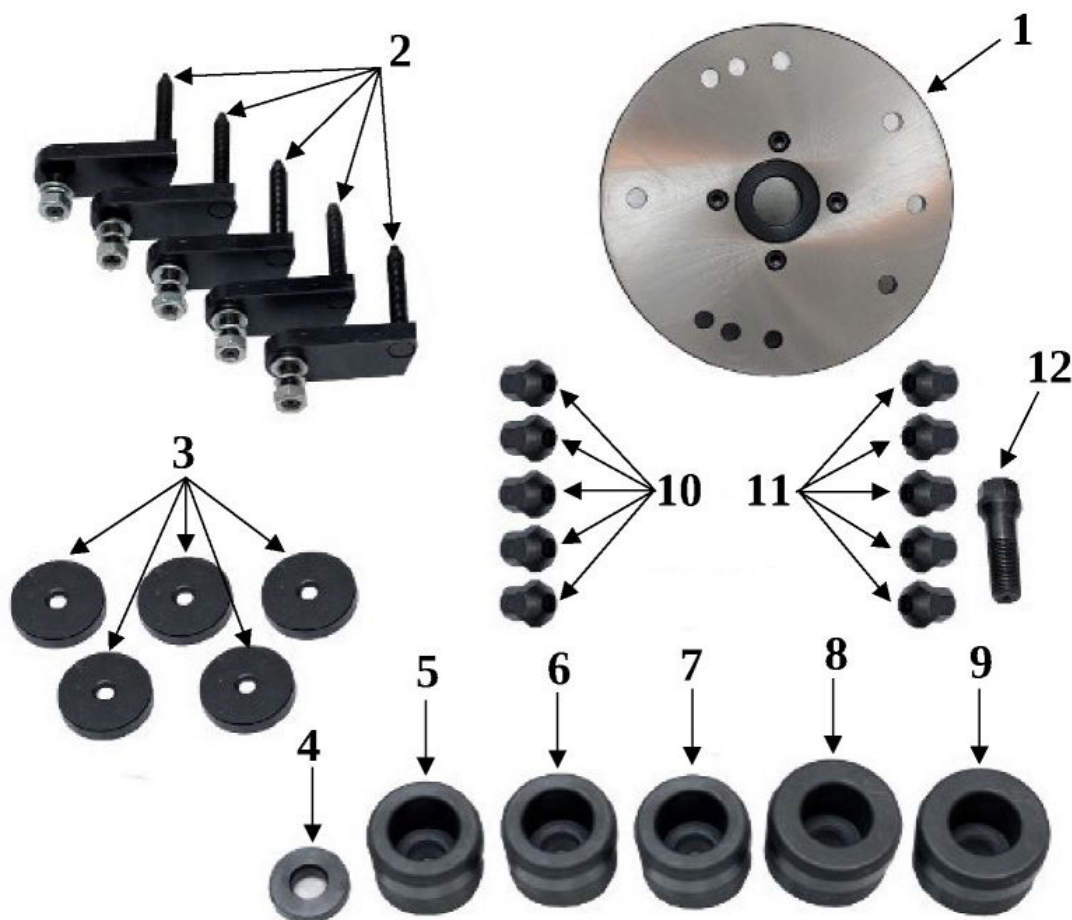

Fig. 6: Spike holder elements:

1: holder shield 2: mounting spikes 3: plate

4: mounting screw pad 5: centering sleeve ø55 6: centering sleeve ø56

7: centering sleeve ø58 8: centering sleeve ø60 9: centering sleeve ø65

10: conical nut 11: spherical nut 12: mounting screw

MOTORCYCLE WHEELS HOLDER MOUNTING



ATTENTION: Motorcycle wheel holder is an optional equipment and not delivered with machine in its standard version.



WARNING: The machine can be delivered with mounted holder.

Motorcycle wheels holder has been mounted the similar way as the car holder (described in section WHEEL HOLDER MOUNTING) . Figure 7 shows the motorcycle holder and describes all its components.

Place the holder bar with the appropriate adapter (1) on the machine's spindle (1 in figure 3). Screw the handle axis (3) to the spindle with a shorter screw and tightened till the end with a screwdriver 22.

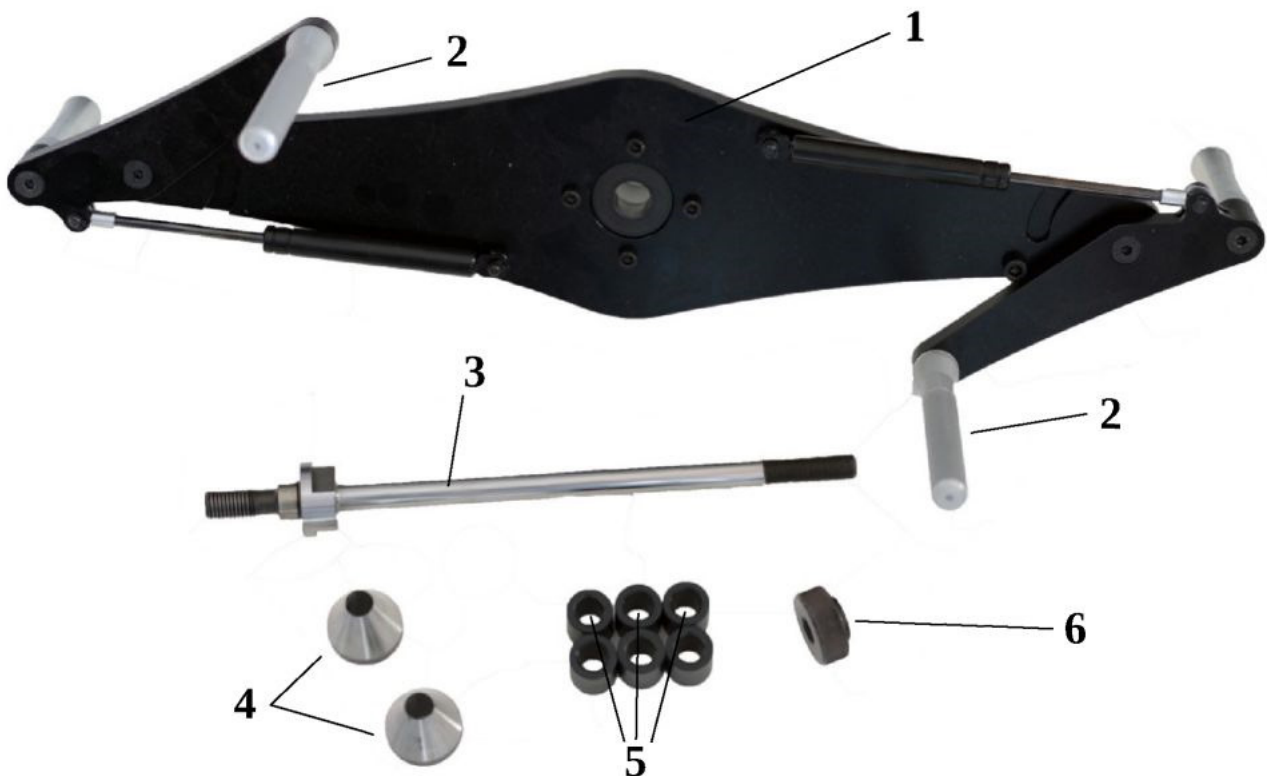

Fig. 7: Motorcycle holder elements:

*1: Holder bar with with adapter 2: tyre clamp 3: holder axis
4: conical sleeve – 2 pcs. 5: offset sleeve – 6 pcs. 6: holder nut*

WHEEL MOUNTING

Mount the car wheels holder the wheel balancer (figure 3) as described in section WHEEL HOLDER MOUNTING.

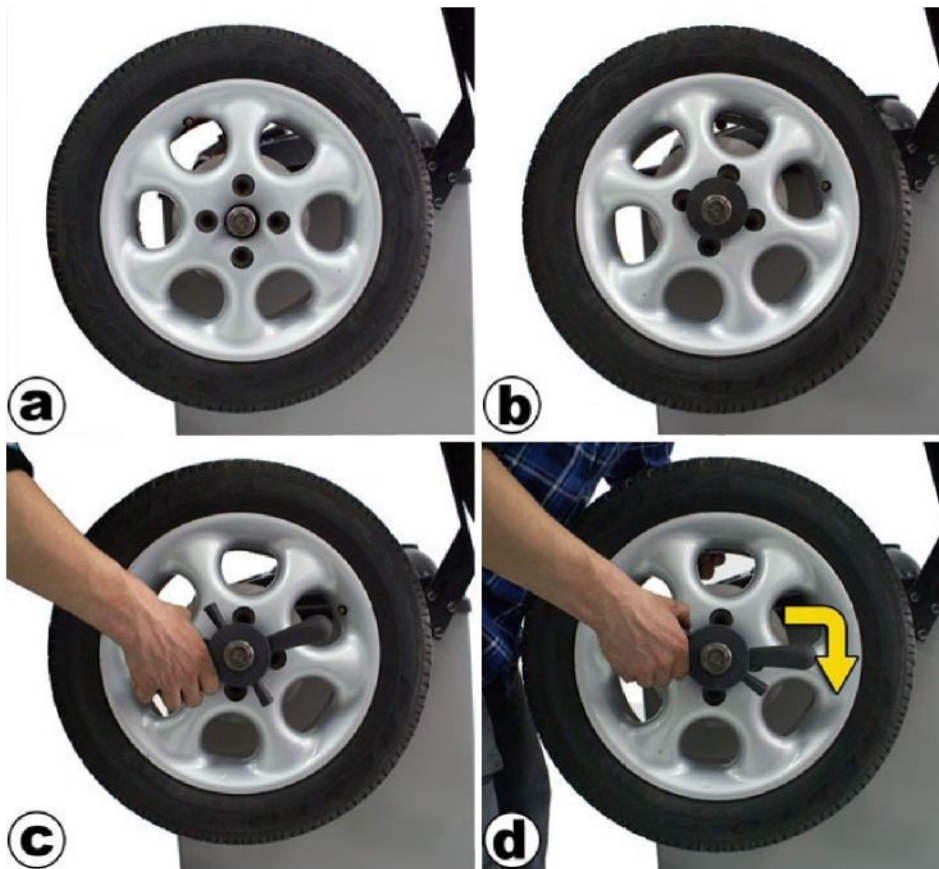

Fig. 8: Wheel mounting on holder

Figure 8 shows the four stages of mounting a car/van wheel in the balancer holder.

- Place the wheel with a central hole on the handle axis (a),
- Insert the centering cone and place wheel on the edge of the cone (b).
- Set the clamping nut (figure 5) to the open position, place it on cone and push it with the wheel towards the machine as far as it will go (c).
- Using your left hand support the wheel, grasp the nut with your right hand, set the clamp nut to the closed position and tighten all on the holder until it stops (d).

Figure 9 shows the two stages of removing the wheel from the balancing machine holder.

- To disassemble the wheel set the clamping nut in the open position (a) and unscrew it by a slight angle (b).
- When the nut is loose remove the wheel from the holder.

The holder enables the mounting of wheels with different rim shapes or centering hole diameters. Options for a different cones are shown in Figure 10. When using one of the centering cones (Figure 4) mount the wheel from the outside as shown in Figures 10a and 10b without using nut 6 or spring 4 (Figure 4). If the rim requires the use of a cone from the inside first put pressure on the nut (figure 12) and then put the spring and the cone on the spindle so that both elements face the larger base to the machine (figure 10c).



Fig. 9: Removing wheel from the holder.

Then place the wheel on and fix with a nut and clamp. All the above-described mounting methods are additionally presented in Fig. 10.

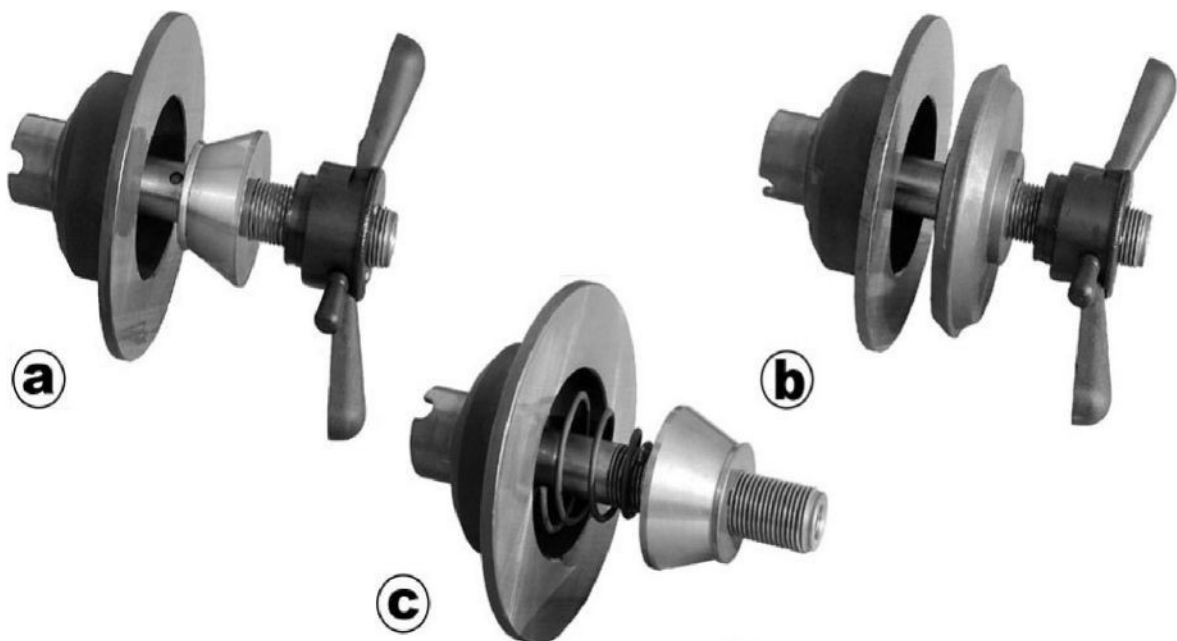

Fig. 10: Various ways to use the handle and its accessories.

When centering cones are used on the outer side of the rim remove the clamp from the nut. To do this you need to pull the clamp along the axis so that it jumps off the catch (you can gently lift the clamp with a screwdriver until the catch is completely released).

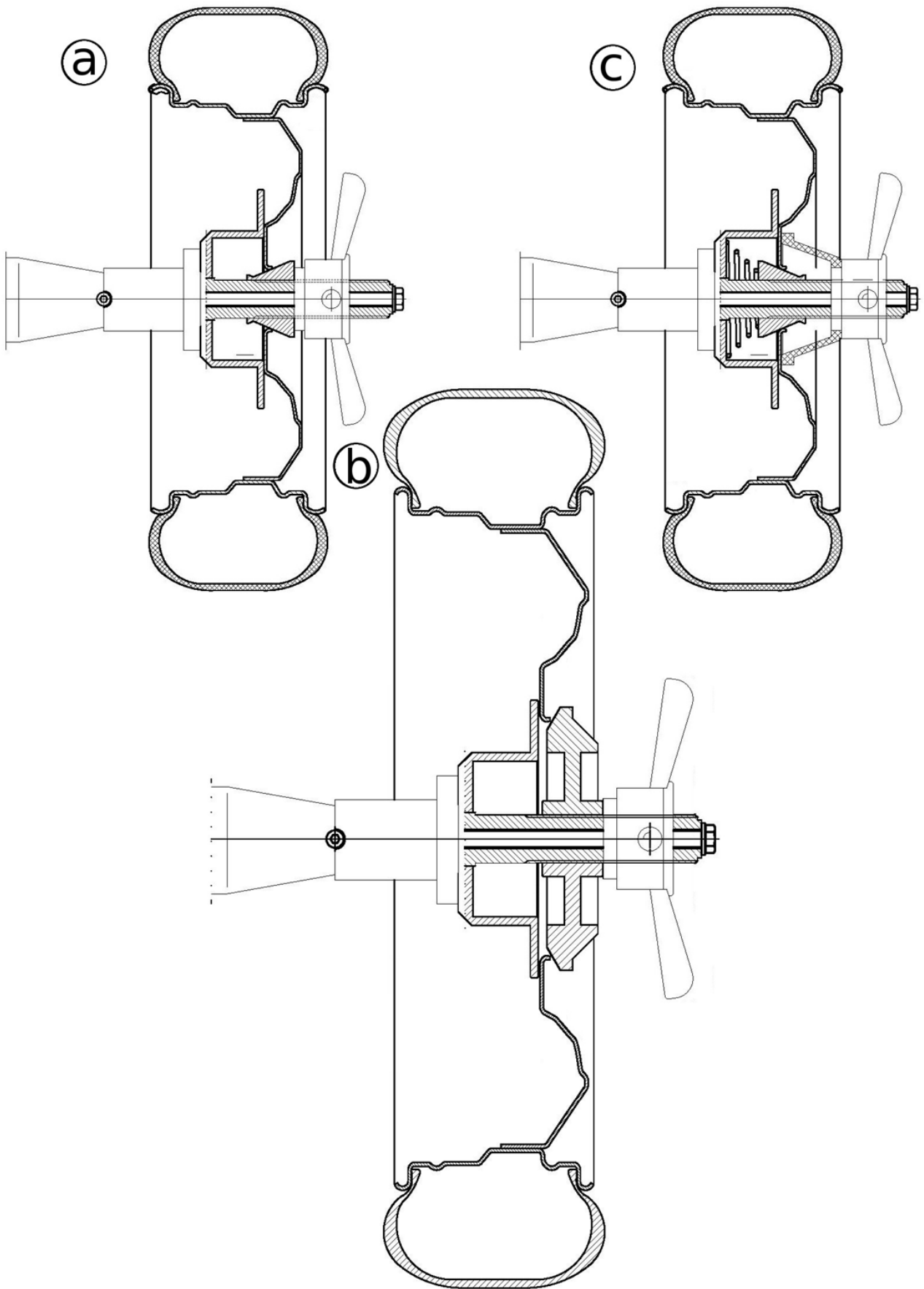

Fig. 11: Wheel mounting for different cones and their configurations



Fig. 12: Nut with mounted clamp

CAR WHEEL ON SPIKE HOLDER

If the balanced wheel rim does not have a center hole a spike holder should be used. Figure 13 shows the four steps wheel installation on a spike holder.

- Check, depending on the balanced wheel, which of the centering sleeves (5 ÷ 9 in Fig. 6) fits the rim hole best (if none is suitable or the rim does not have a hole on the inside, use a washer under fastening screw 4 in figure 6).
- Place the disc with the appropriate adapter 1 from figure 6 on the spindle and tighten it with the screw 12 from figure 6 with a sleeve or washer (figure 13a).
- Depending on the rim holes number screw the spikes (2 in figure 6) to the disc according to the numbers on its back. For example, if the rim has 5 holes all the spikes should be screwed to the holes with the number 5 on the back of the disc (figure 13b), if the rim has 6 holes, use 3 pins, screw to the holes with the number 3 and put them every other hole in the rim. The spikes should be tightened using the attached nuts and washers in such a way that they do not unscrew but at the same time that you can turn the pin tightly (first a flat washer, then a springy one and then the nut). If there is enough space place the pin plates with the recess facing outwards and then position them so that the wheel can be inserted into the holder (figure 13c).

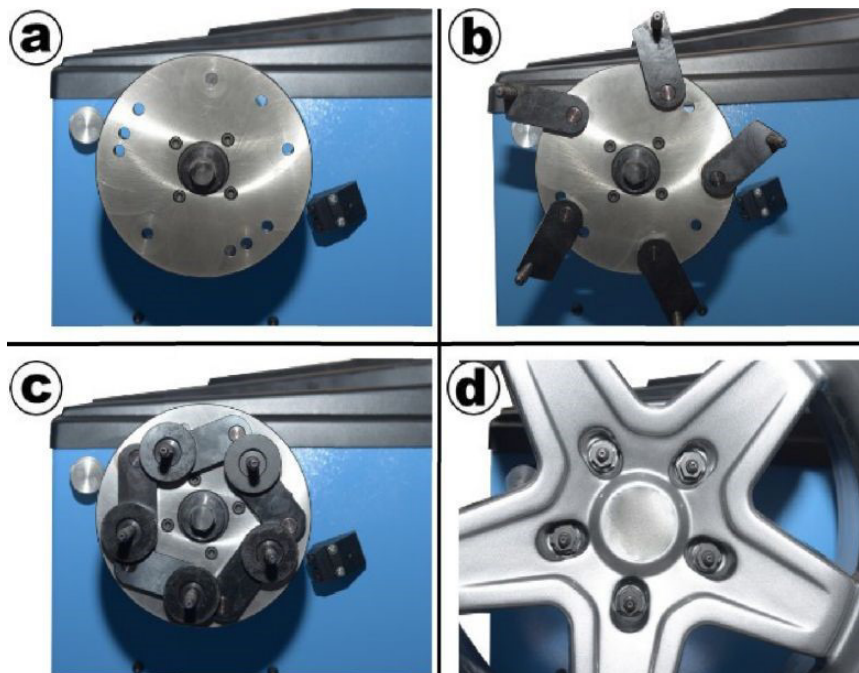

Fig. 13: Mounting the wheel without central hole on spike holder



WARNING: In case of problems with the spikes alignment to the wheel holes the spikes can be pre-positioned before mounting the spike holder on the spindle by fitting it to the disassembled wheel.

- To screw the wheel to the holder (figure 13d) use a conical nut (10 in figure 6) or a spherical nut (11 in figure 6) depending on the nuts/bolts which attach the wheel to the vehicle.

MOTORCYCLE WHEEL

If there is a car wheel holder mounted on the balancer (figure 3) dismantle it and install the motorcycle holder (figure 7) as described in section THE MOTORCYCLE WHEEL HOLDER MOUNTING.

Figure 14 shows the four stages of mounting motorcycle wheels in the balancer holder.

- Make sure that the tyre clamps 2 shown in figure 7 are in the open position and that one of the cones 4 in figure 7 is placed on holder axle (figure 14a).
- Slide the wheel to the end and put it on the cone (figure 14b), slide the second cone over the axle and move it so that it fits into the wheel bearing.
- To fast the wheel well place the offset sleeves 5 in figure 7 behind the cone so that there is a place for the holder nut 6 in figure 7 (figure 14c).
- After tightening the nut and making sure that the wheel has no play in the spindle axis adjust the tyre clamps so that they rest against the tyre front (figure 14d).



Fig. 14: Motorcycle wheel mounting on the holder.

MACHINE OPERATION

The machine has a graphic interface displayed on the monitor (figure 1 (4)). You can select individual functions in menu or change parameter values moving the cursor (dark rectangle on the currently selected icon) by a wheel mounted on the machine holder and by green and red buttons (figure 1 (15)) located on the machine tooltray (figure 1 (14)). The green button activates the icon on which the cursor is currently located. The table below shows the actions that the green button activates depending on the type the icon:

Action	Example
Screen changing	Entrance to another screen in main menu, icon selection  .
Function activating	Measurement start or end, results renewal.
Immediate value change	Switching on/off, for example ultrasonar sensor on the settings screen.
Value changing mode	Wheel parameters changing mode and result saving, date and hour setting, key selection mode.

The red button only has two functions as shown in the table below:

Action	Example
Screen exit	Quick return to main menu without icon  .
Function deactivation	Canceling the wheel parameters change (restoring the previous value), exit key selection mode.



ATTENTION: Regardless the described above functions pressing any button during the measurement will stop the wheel and the measurement.

In value changing mode, when the cursor is on the icon, the green button deactivate the cursor and wheel movement change the value. To confirm the value press the green button. To cancel changes and return to the previous value press the red button.



ATTENTION: The option „ HIT THE WHEEL” can be activated in the setting screen. See the details in SETTINGS.

The machine can be equipped with touch-screen monitor. In this case the touch works along with the cursor movement by the mounted wheel.

MACHINE SCREENS DESCRIPTION

The balancing machine is controlled by a program activated after turning the power on. To turn the machine on press the button 9 (picture 1) on the housing. If the mains voltage is correct the button lights up and the machine program starts. Initially Uni-Trol logo will be displayed on the monitor to signal system start-up and testing. After several seconds the initial screen with the main menu of the program will be displayed on the monitor.

MAIN MENU

Figure 15 shows the main menu screen. This allows you to go to the appropriate machine screen to start measuring or change settings. To switch to another screen place the cursor on the appropriate icon and confirm your choice. From the main menu screen you can go to the screens for measuring the unbalance, optimizing the unbalance of the rim-tire system, calibrating the measurement system and balancing machine settings.



Fig. 15: Main menu screen

The machine should be switched off from the main menu level. Place the cursor on icon  and confirm selection. Wait some seconds until „No signal” appears on the monitor or monitor colour will change. Switch the machine with electric buton 9 in Figure 1.



ATTENTION: It is important to switch the program with the button  before disconnecting the machine from the electric supply. In such a case all setting will be saved

UNBALANCE MEASUREMENT

Select the icon  to enter unbalancing program in main menu. The presented in Fig. 16 will appear. Left circle responds to the inner rim side, right circle responds to the outer side.





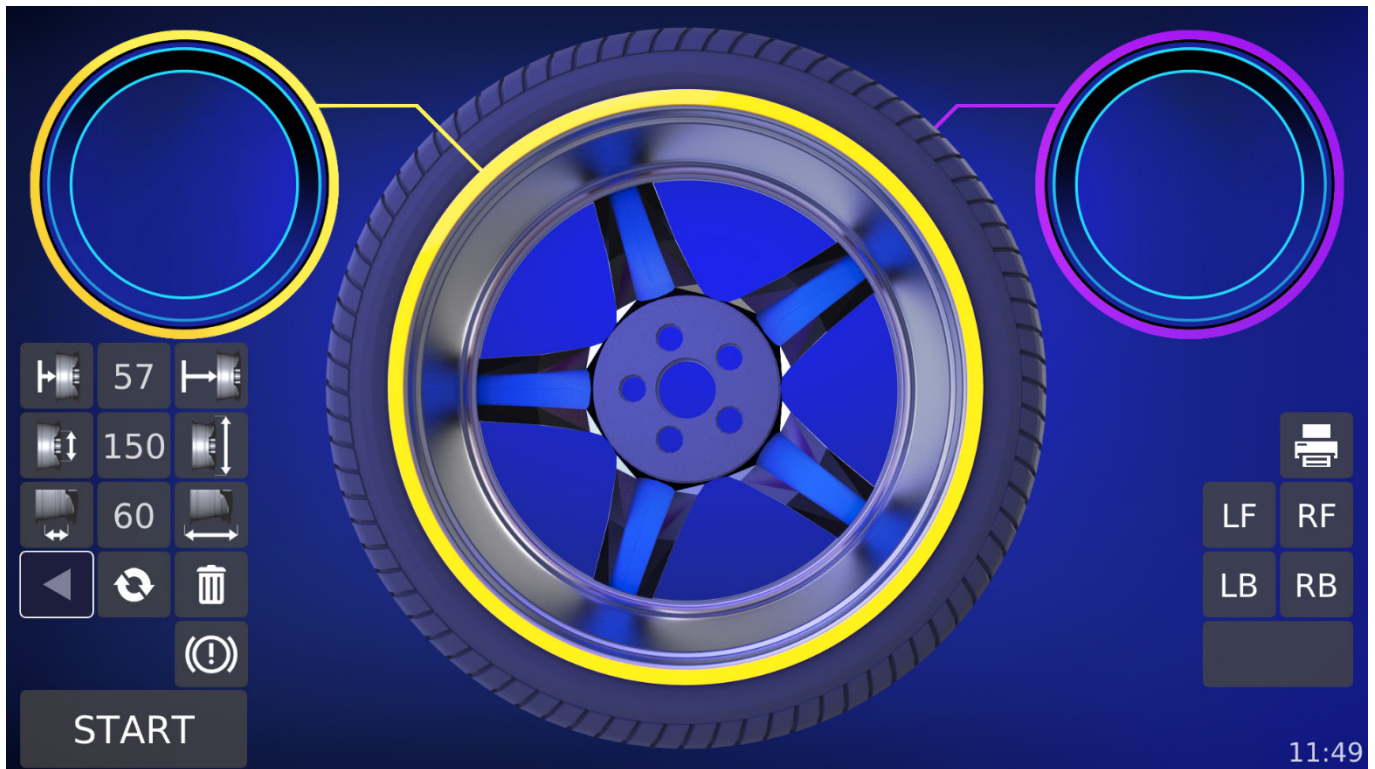













ATTENTION: In case of the static balancing there is no left circle on the screen.





Rysunek 16: Imbalance measurement screen before measurement

The buttons area is divided as shown in the Fig. 16 and 20. Some icons are visible only before the measurement, some – only after measurement. All screen icons are presented below:

-  Return – return to the initial program screen
-  Renew – show again the measurement result
-  Clear – cancel the current weights placing points
-  Offset – increase wheel offset value
-  Offset – increase wheel offset value
-  Wheel diameter – decrease wheel diameter value
-  Wheel diameter – increase wheel diameter value
-  Wheel width – decrease wheel width value

-  Wheel width – increase wheel width value
-   Brake – wheel brake (white – on, red – off)
-  3P – hidden weight program
-  Loupe – check measurement results without round-off
-   Weight fastening mode
-  START – program start
-  STOP – program end

Additionally the print icons on the right side may be displayed on the screen. They are active only when printing is enabled in the settings. See the chapter PRINTING for a description. A field below the print icons is empty in Figure 16 and shows the weight distribution icon in Figure 20. This field appears after taking the measurement with the measuring arm or pressing the button , erase by pressing  and shows the selected weight fastening mode.

MEASUREMENT

Wheel dimensions measurement

The measuring arm is a tool for entering rim offset and diameter. The machine sets the weight fixing mode according to the measurement method performed by operator with the measuring arm. After the arm has been extended the machine selects automatically the weight placement mode. This mode, based on the measurement method, is able to determine whether the external (right) weight will be glued in the center of the rim or mounted on its outer side. You can also enter the offset, diameter and width parameters "manually".



ATTENTION: To enter all parameters from the beginning select *Clear* . If the voice synthesizer is on the machine will communicate „*New measurement*“.

To measure with the measuring arm extend the arm so that the laser starts displaying a line and a dot on the rim. Regardless of whether the weight in space A from Figure 17 is to be clipped-on or taped-on - the laser dot of the arm is connected to the line **at the place of the planned weight attachment**. For clipped-on weights the dot should be aligned with the line on the left edge of the rim, as shown in Figure 18a. In the case of taped-on weights the dot should be placed on the line in the place where the weight is glued, as shown in Figure 18b.

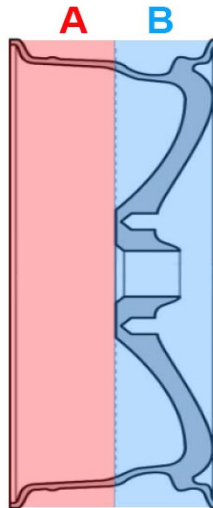

Fig. 17: Weights fastening zone
A (inner / left) and B (outer / right)

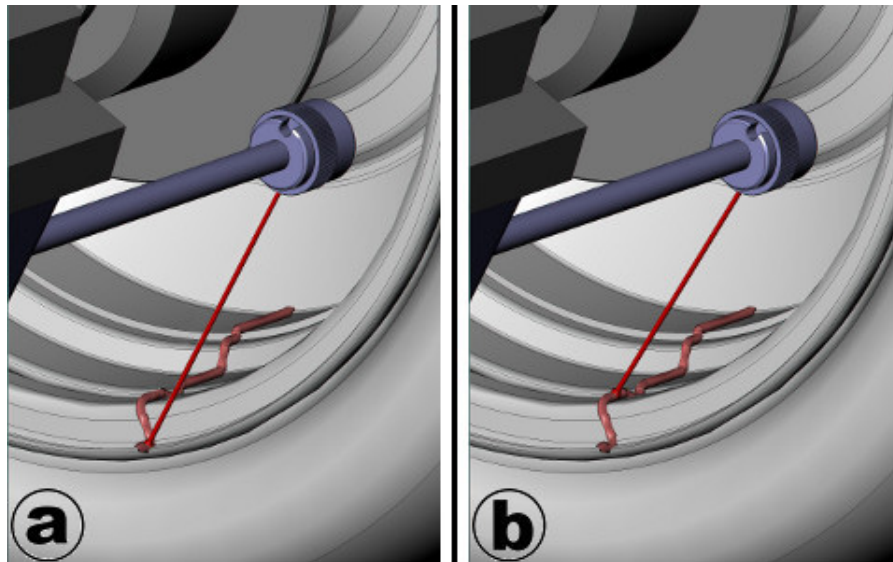



Fig. 18: Aimed laser dot point:
a) for clipped-on weights b) for taped-on weights



ATTENTION: If it is impossible to measure the offset by measuring arm measure the distance from the place of clipping-on the weight on the rim edge in millimeters, then subtract 40 mm and enter  and .



ATTENTION: For 2451USG, 24/7 to measure the diameter place the measuring arm head (1 in fig. 19) by the upper rim edge (2 in fig. 19) where the weight is going to be placed (fig. 19a for clipped-on weights, fig. 19b for taped-on weights).

After setting the laser in the appropriate position you need to wait about 2 seconds until the machine save the entered parameters. After the signal the second measuring phase begins with

the measuring arm which will allow to determine where the weight for space B of the wheel from Figure 17 will be mounted. If weight is attached to the outer zone B (Figure 17) (not in the center of the rim but on its right edge) put the measuring arm in its place to the zero position.

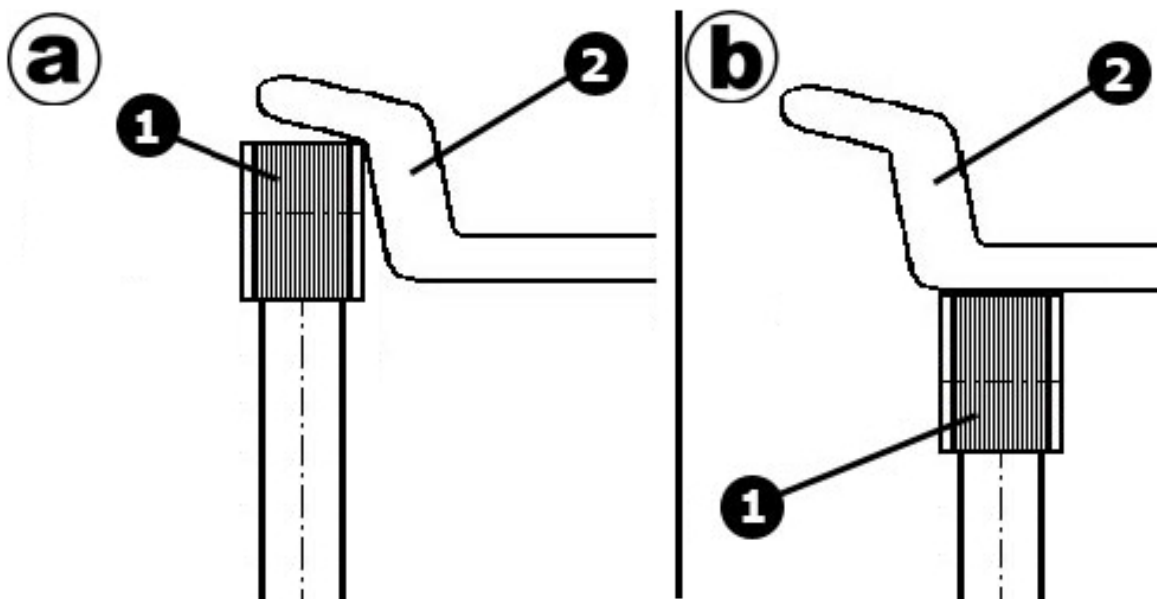

Fig. 19: Measuring arm head application place:
a) for clipped-on weights b) for taped-on weights

This is the end of the measurement. The machine will automatically measure the width of the wheel using the ultrasound sensor while closing the cover. If the ultrasound sensor is turned off, you must manually enter the wheel width.

If the weight is to be mounted in the center of the rim in area B from Fig. 17, after saving the first measurement, insert the measuring arm inside the wheel. This will cause the wheel width to begin to change as the arm continues to move towards the center of the rim. After setting the arm head in the position directing the dot to the line, wait approx. 2 seconds until the machine emits a sound signal and records the result.

In the static mode of unbalance measurement there is only one correction point. If the measuring arm is moved deeper into the rim for the second time it is impossible to save the second correction point.



Unbalance measurement

After the measurement by measuring arm the unbalance measurement may start. When Autostart (the function described in SETTINGS) is on it is enough to close the hood and the measurement will start automatically. If Autostart is off close the hood and press **START**.

During the measurement the cursor stay in the same position where **STOP** appears. To interrupt the measurement press any button – green or red – or touch **STOP** on the screen if the monitor is touch-screen.

After the wheel has reached the measuring rotations the machine measures the correct imbalance. After completing the measurement and stopping the wheel rotation the cover can be opened. If the auto-guidance option (described in the SETTINGS) is activated it will automatically guide you to a closer imbalance place.

The measurement results are displayed in two circles on the left and right side of the screen, as shown in Figure 16. The markers moving along the circles symbolize the places where weights

are attached. When rotated the color of the markers changes from red at the point opposite to the unbalance location to green at the unbalance location. The weight placement is indicated by a segment on the circle in the imbalance result circle. The location of this segment can be changed by  (clipped on 12 o'clock) or  (taped on laser line).



ATTENTION: It is not allowed to change the position of the weight if the mode selected with the measuring arm is currently displayed. You should change the weight position if the program shows a different mode than the one selected with the measuring arm.



ATTENTION: The weight position cannot be changed for the following machine settings:

- a weight mounted in the center of the rim in area B from Figure 17,
 - with a motorcycle adapter,
 - for static balancing.
-

If the marker is in the segment marked with two dashes the outer circle will be bold, an audible signal will sound and the brake will be applied. This means that the wheel has been placed in the position for placing the balance weight.

If the segment marked with two lines is at the top of the circle after the wheel is placed over it, attach the weight "at 12 o'clock".

If the segment marked with two lines is at the bottom of the circle, the laser line will light when you align the wheel over it. Extend the adjuster to the previously indicated place of weight attachment. When the required distance of weight mounting (indicated during the measurement with the measuring arm) is reached a sound will be heard and the laser dot will light up. Place the laser dot on the displayed line to accurately place the weight in the previously selected position.

Correctly indicated correction points (place of weight placement) are valid until they are redefined. This means that each successively installed wheel, after pressing START, will assume previously defined points. This is valid until you select an option *Clear* .

PROGRAM 3P – HIDDEN WEIGHT

If we want to hide the weight so that it is not visible after putting the wheel on, we can break it into two weights, which will be placed in places not visible from the outside - behind the rim spokes. Program 3P is active in dynamic mode and related to the right unbalance in zone B from Figure 17 for a point defined inside the rim or in static mode for a single point.

Activate the program by pressing **3P**. It always appears when the correction point in zone B from Figure 17 is defined inside the rim or when we measure in static mode. The minimum unbalance value for which the hidden weight option is activated is 7.5 g. An exemplary screen after the measurement has been made is shown in Figure 20.

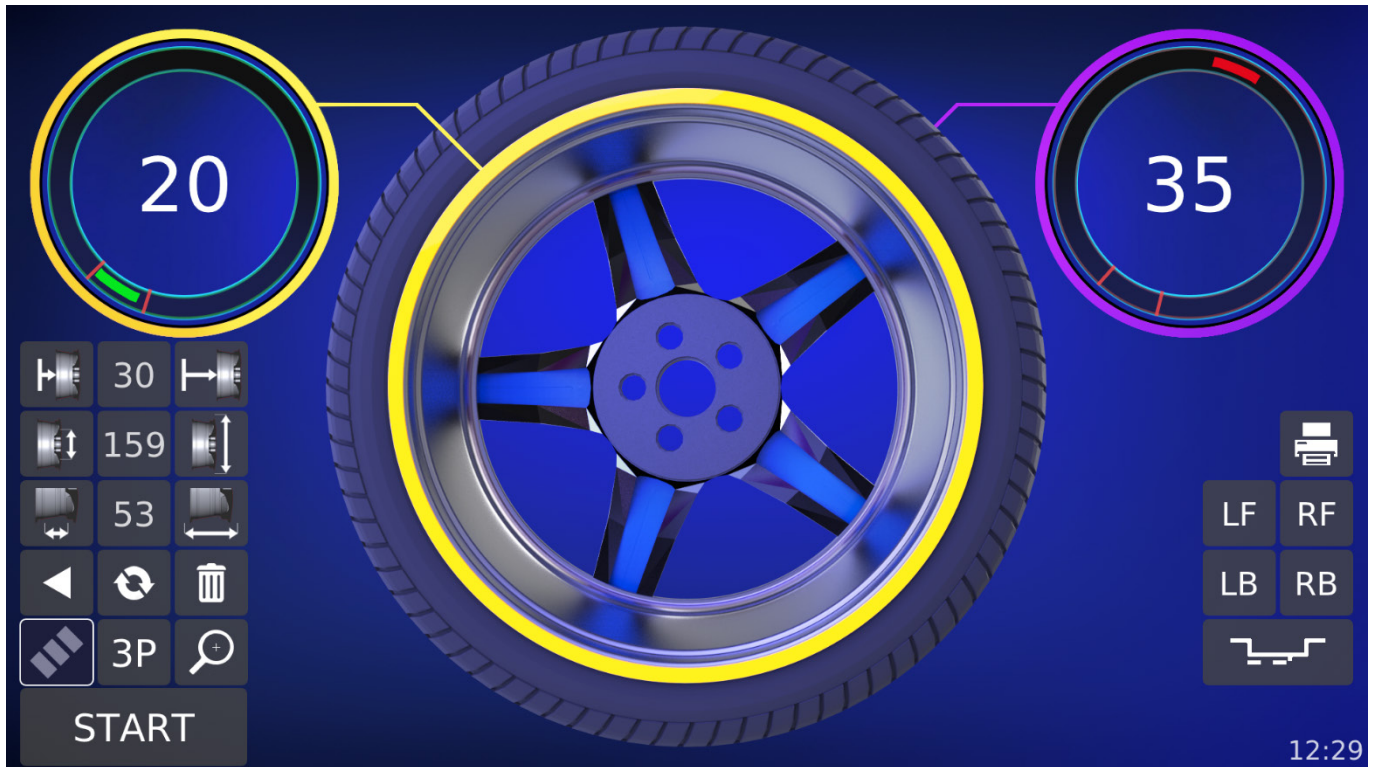

Fig. 20: Exemplary screen after the measurement

The range for entering the position of hidden weights is approximately +/- 30 degrees from the original location. When defining these points the laser line lights up in the permitted range. In the hidden weight program, cursor movement is blocked and an information box appears in the center of the screen that describes the steps to be performed.

Selecting **3P** activates the program and the icon change to **3P1** (Fig. 21). You should then set the wheel to a position convenient for the first hidden weight (but within the allowable range indicated by the lit laser line) and confirm with the green button.

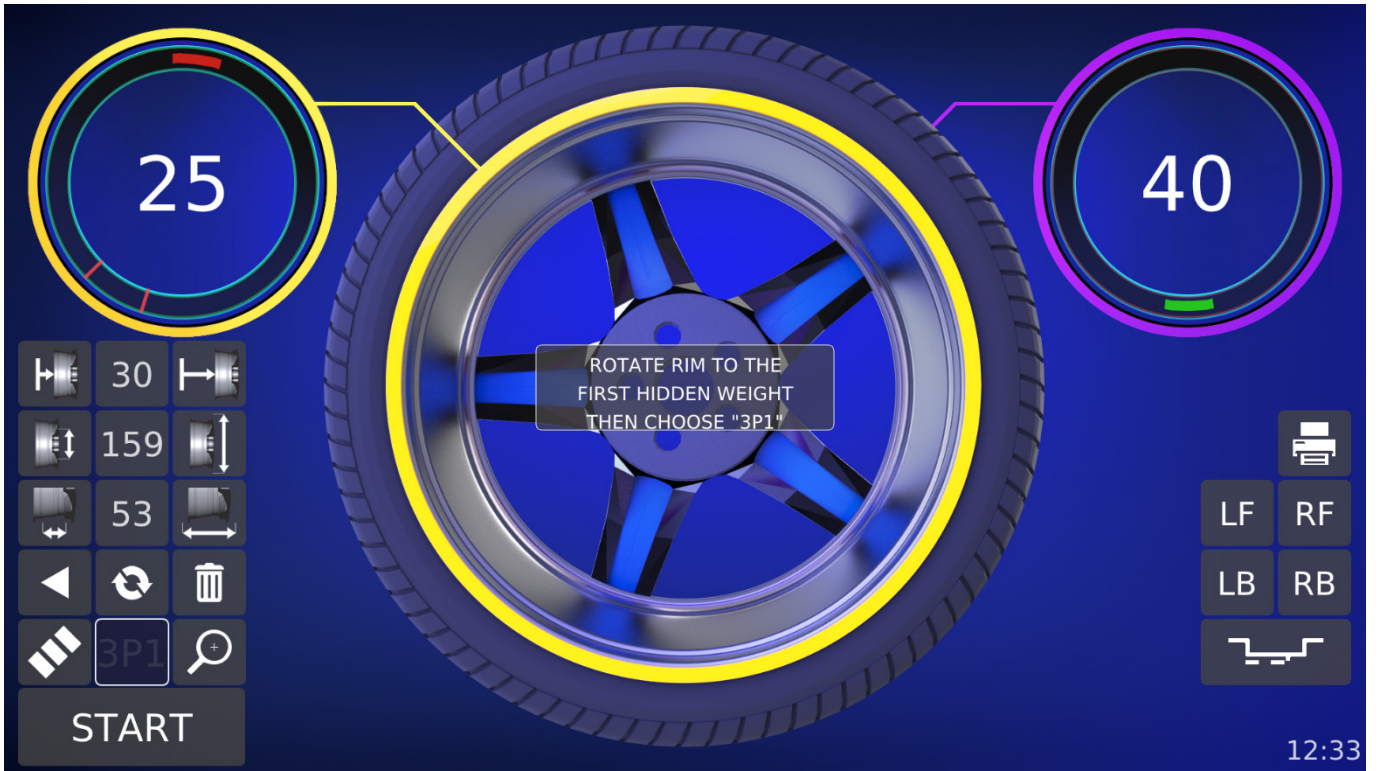

Fig. 21: Hidden weight function started – first point selecting

After the definition of the first point pictogram **3P1** changes to **3P2**. Set the wheel to a second convenient position within the allowable range indicated by the lit laser line, as in Figure 22, and confirm with the green button.

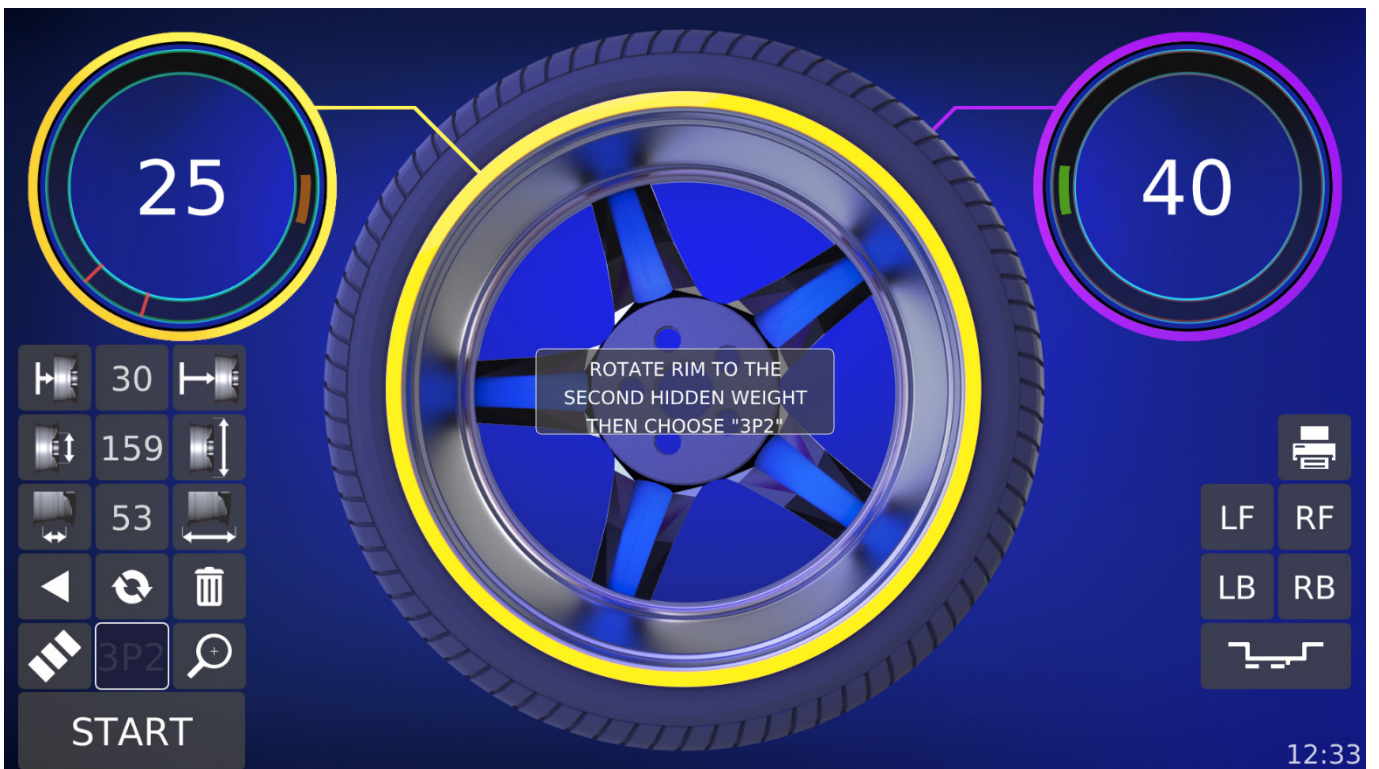

Fig. 22: Hidden weight function started – second point selecting

After the definition of both points pictogram **3P2** disappears and in the right result field, depending on the wheel position, the unbalance value or the text "3P" appears. Possible indications of the right result field are shown in Figure 23.



To return to the state before defining the location of hidden weights choose the button *Renew* .



Fig. 23: An example of the result fields for the hidden weight program

OPTIMIZATION

Select  on the main screen to move to optimization program. The screen shown in Figure 24 will appear on the monitor. On the left side there are icons and buttons that call the program functions while on the right side there are instructions for the wheel optimization.

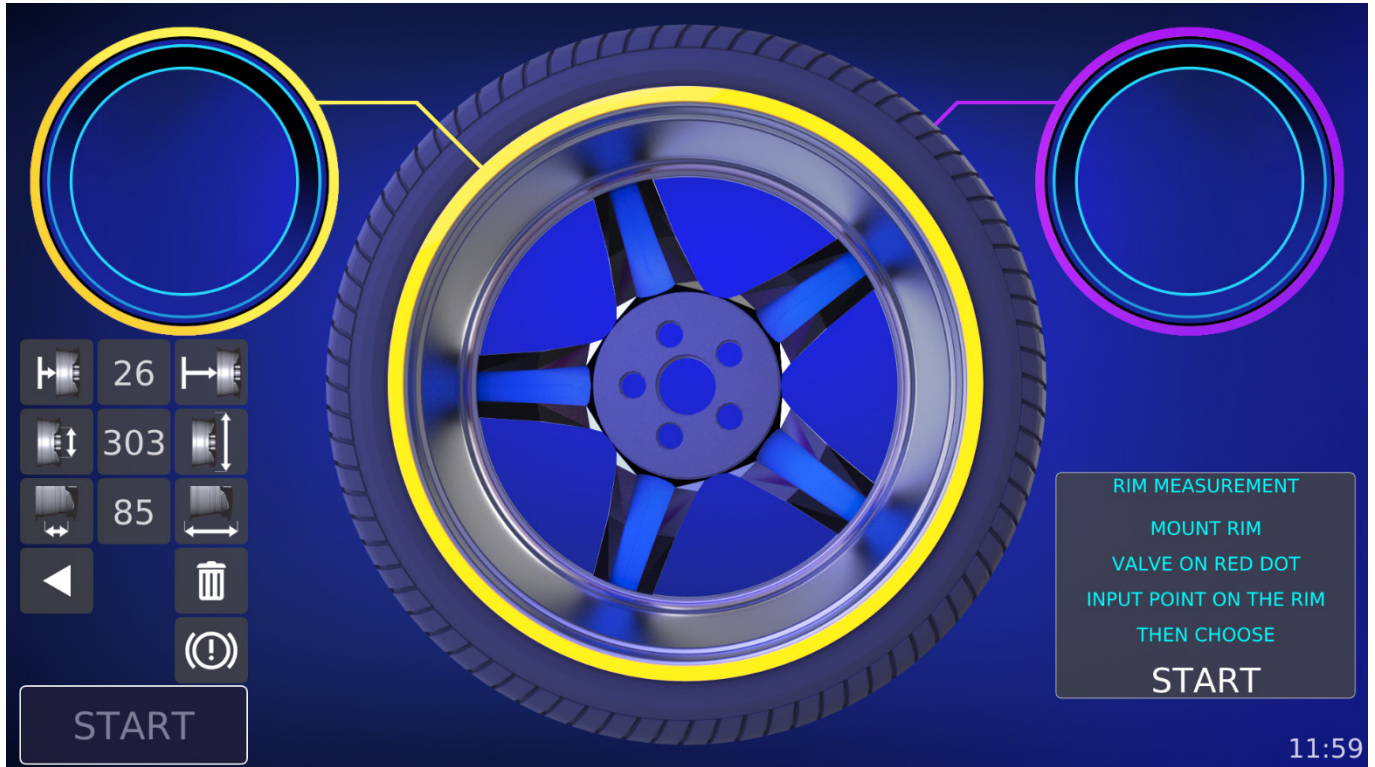



Fig. 24: Inicial optimization screen

We start the optimization by measuring the imbalance of the rim itself (without the tyre). Place the rim in the holder with the valve on the holder marker (3 in Figure 3) so that in the second run (after installing the tyre on it) you can mount the wheel in exactly the same way. Using the measuring arm indicate the point on the inner edge of the rim (space A in fig.17), close the hood, select . The optimization has been measured by using the rim width determined from the indicated point and from the ultrasound measurement performed when closing the hood. In case of optimization the entry of the second point inside the rim is blocked.

After the measurement is completed the program will display the rim imbalance on the screen. An example of a screen after measuring the rim is shown in Figure 25. To continue the measurement put a tyre on the rim, pump it and place the already assembled wheel on the balancer holder remembering about the orientation in relation to the holder (valve on the dot).

Press  and machine will start the measurement of the wheel.



ATTENTION: If the rim itself turns out to be balanced further optimization does not make sense and the process can be interrupted at this point.

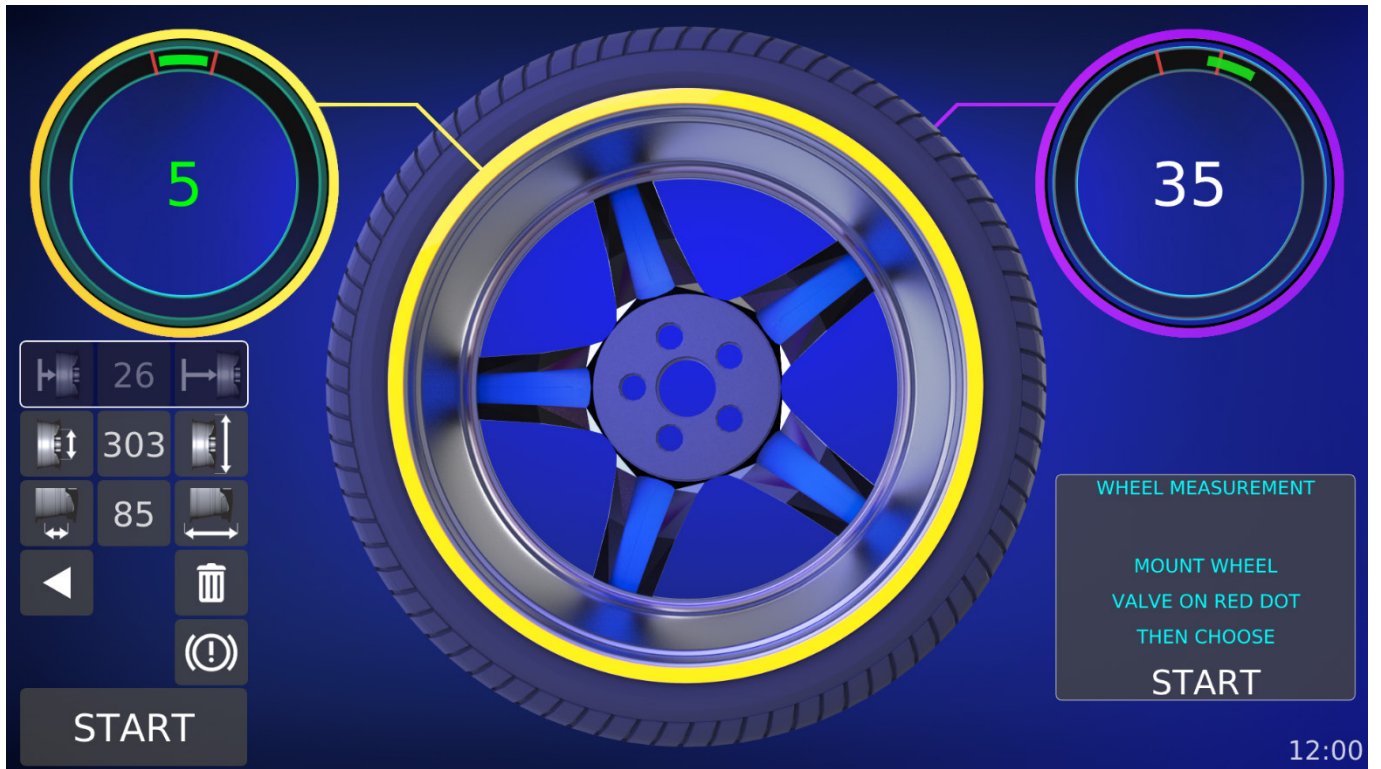

Fig. 25: Sample optimization screen after rim measurement

The result of the optimization is the gain in grams after rotating the tyre in relation to the rim. An exemplary result screen after optimization is shown in Figure 26.

To perform this operation correctly:

For rims - move the wheel so that the left marker in the RIM field is "at 12th "in the doomed segment. After aligning the wheel mark a point on the rim with chalk.

For a tyre - move the wheel so that the right marker in the TYRE field is "at 12th "in the indicated segment. After aligning the wheel mark a point on the tyre with chalk.



Fig. 26: Sample optimization screen after wheel measurement

After deflation move the tyre against the rim so that the marked points on the tyre and rim align. After matching the rim with the tyre carry out a normal measurement of the wheel unbalance.



ATTENTION: After the optimization is completed the button  is not displayed.

CALIBRATION

Press  to move to calibration screen from main menu. In this program we can calibrate the parameters of the machine responsible for the correct calculation of unbalance in two ways: using a special device - calibrator - attached to the machine (the screen shown in Figure 27), or using a balanced wheel with a calibration weight attached on the outside (visible screen as in figure 28). The value of the calibration weight is 80g.

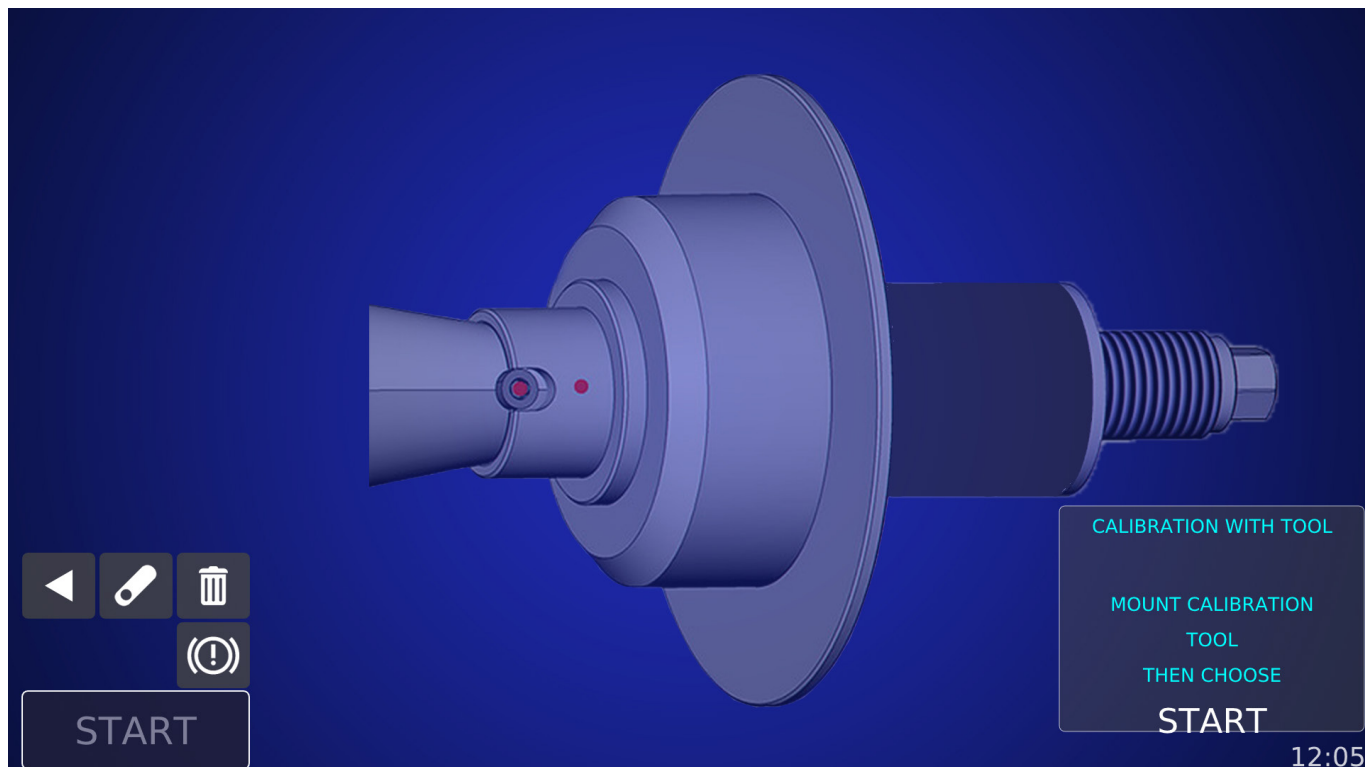

Fig. 27: Calibration with calibrator



Fig. 28: Calibration with wheel

The button area is divided the same way as the unbalance measurement screen except for the calibration mode selection button:



Calibration mode - the currently displayed icon indicates the selected mode.

Calibrating with a balanced wheel use the measuring arm to indicate the point on the inner edge of the rim where the weights are loaded then impose the calibration weight (80g). Calibrating with a calibrator simply place it on the holder. In this mode the wheel parameters are not visible.

Press  to start calibration. After the measurement is completed the screen shows information about the correct or incorrect result of the calibration.

SETTINGS

On the "Settings" screen you can change some machine's operational attributes such as: language, sound volume, unbalance measurement accuracy, check the current version of the program, etc. To enter "Settings" from the initial screen press the icon .



Fig. 29: Settings screen

SOUNDS

This group of options presented in Figure 30, allows you to set the volume of the sounds emitted by the machine and enable or disable the voice messages. If the voice synthesizer is turned off the machine only beeps.

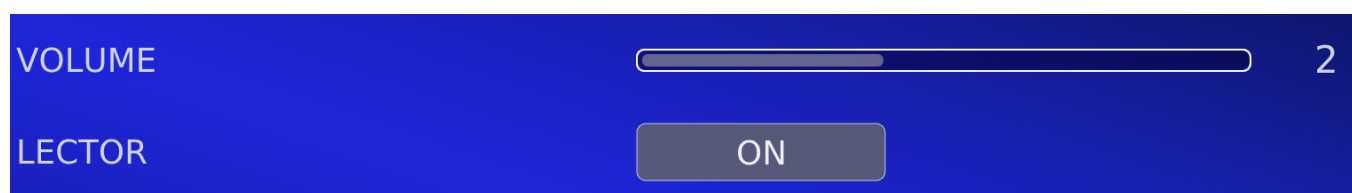

Fig. 30: Settings sounds

BALANCING

It is possible to define the values presented in Figure 31. Below are the individual options:

RESULT TRESHOLD - value below which the balancer treats the measurement result as zero. The defined thresholds range from 1g to 10g in 1g increments.

ROUND RESULT TO- Indication of the result every 1g or every 5g. For example, for an unbalance of 11 and with rounding 5 selected, the result is 10.



Fig. 31: Settings balancing

AUTOSTART – after the cover is closed manually, the measurement starts immediately. If it is off the hood must be closed manually and then selected **START**.

AUTOTARGETING- automatic guidance to the weight placement point after the measurement.

WHEEL HOLDER TYPE - wheel holder selection. If you change the holder change this option.

BALANCING MODE - choose between dynamic and static balancing. The option ASK makes it possible to change the mode from the level of the measurement screen with DYNAMIC and STATIC described in UNBALANCE MEASUREMENT.

SM FILTER - Small signals filter excludes small signals caused by unbalances.



ATTENTION: small signals filter is active only for dynamic mode. In case of the BALANCING MODE set to ASK, the availability of changing the low signal filter setting depends on the currently selected mode.

Ultrasound

Ultrasound options (Fig. 32) provide the automatic rim width measurement by ultrasound sensor when closing the hood.



Fig. 32: Ultrasound settings

CLOCK

The machine has a built-in real-time clock powered by a battery. The clock runs normally and maintains the correct date and time even when the power is turned off. In case the set date and time differ from the actual ones, you can use this option to set the required values. From now on, as long as the backup battery is functional, the clock will remember the new date and time set.



ATTENTION: If after restarting (turning the machine off and on) and the previously set correct time the wrong time appears - contact the service center.



Fig. 33: Clock settings

PRINTING

This group shown in Figure 34 allows you to set printing options. The available printing options are to send to a printer connected to the machine or to copy the generated PDF file to a USB mass storage device. In case of a file you need to connect an external memory to the USB port (Figure 1 (11)) to save the report on it.



ATTENTION: The printer is an optional accessory of the balancer. If it has not been purchased for the machine, please select PDF FILE as the print type and use the USB mass storage device to save the document.



Fig. 34: Printing settings

MISC OPTIONS

Other group shown in Figure 35 contains general settings and information about the machine. Below is a description of the individual fields:

LANGUAGE - selection of the voice messages language and texts displayed by the program.

Select in low right screen corner to reload the program and load the new language.

HIT THE WHEEL – simulation of pressing the green button with by hitting the wheel.

WHEEL MEASUREMENTS UNITS – change measurement unit.

ALL MEASUREMENTS – number of measurements taken.

COMPLETE MEASUREMENTS – the number of measurements completed with the balanced wheel.

SAVED WEIGHTS - the sum of ignored unbalances for measurements finished with balanced wheel after applying the cut-off threshold, rounding the result and the small signal filter.

IP ADDRESS - it is possible for a service technician to connect to the machine. The service technician may ask for machine's IP address.

SOFTWARE VERSION - balancer software version number consists of two elements: RPI and ARD. In case of problems both versions should be provided in cooperation with the service.

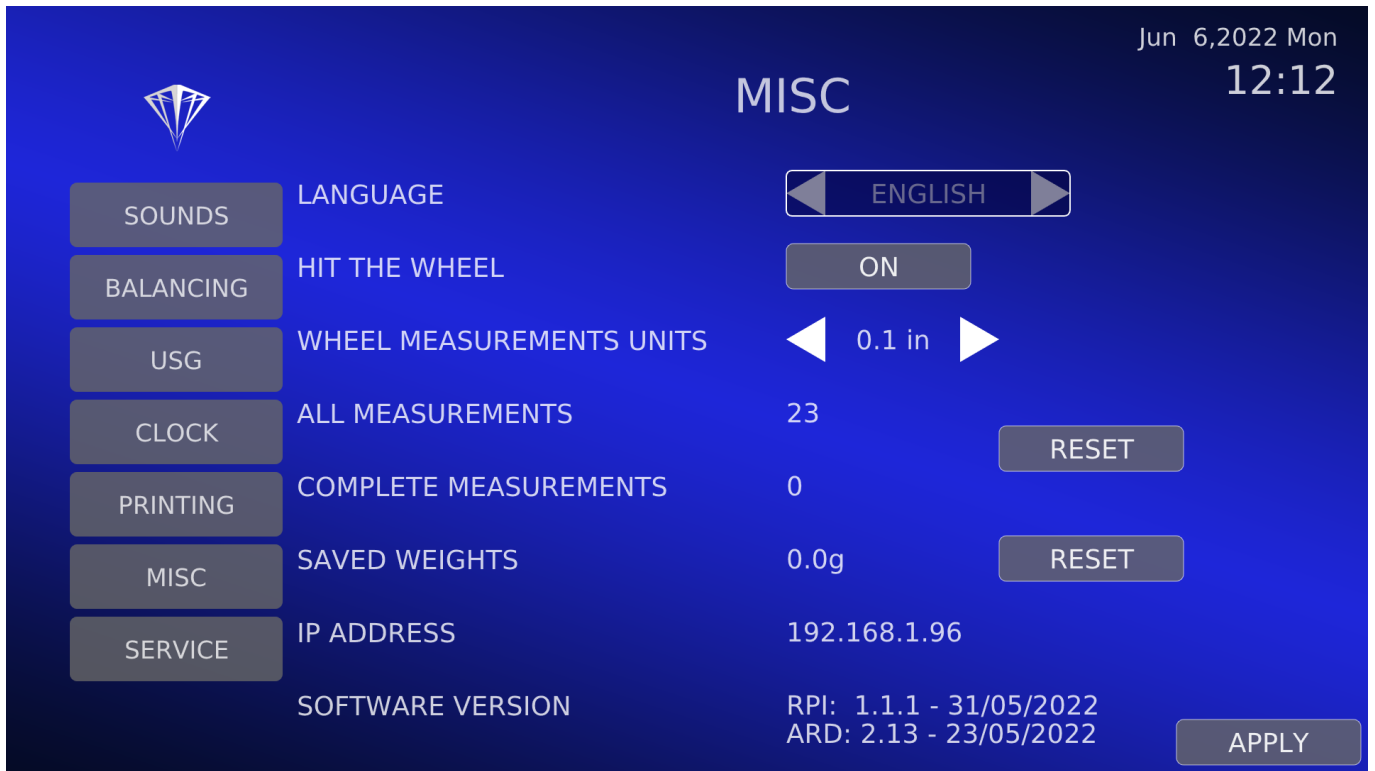

Fig. 35: Other options

SERVICE

When contacting the service and entering a 4-digit code it is possible to read the detailed parameters of the machine which allows you to solve the problem faster. You can enter the service screen after entering the code 1111 and selecting it **ACCEPT**.

PRINTING



ATTENTION: Printing reports works only on a dedicated printer attached to the machine or ordered directly from Uni-Trol.

The printing screen is available only from the imbalance screen and with the printing option turned on in the settings. It allows you to prepare a report for a given vehicle and its wheels. The icons on the right side of the screen in Figure 16 are described below:



Printing – go to printing screen



Left Front – left front wheel (for car adapter)



Right Front – right front wheel (for car adapter)



Left Rear – left rear wheel (for car adapter)



Right Rear – right rear wheel (for car adapter)



Front – front wheel (for motorbike adapter)



Rear – rear wheel (for motorbike adapter)

PRINT

Print – printing report

If we want to prepare a report for a serviced vehicle select the appropriate icon after the first measurement for each wheel when the unbalance values are displayed **marking where the wheel is mounted**. After selecting all the boxes, enter the printing screen by selecting the icon .



ATTENTION: Selecting the wheel position sets the **currently displayed unbalance measurement results**. Unchecking the icon causes the previously saved values to be reset to zero.

The printing screen is shown in Figure 36. In order to show the screen appearance without some previously selected wheel positions, some of them have been unselected.

The printed report contains the data of the company executing measurement and the data of the customer for whom the wheels are balanced. In the middle of the screen there are fields for selecting the data to be edited. In the top selection window you can select whether you are editing company or customer data. You only need to fill in the company's data once, it will be remembered and you won't have to edit it anymore.

The following fields are available:

Company	Customer
Name	Name and Surname
Address	Vehicle
Phone	Reg. number
E-Mail	Mileage
WWW	

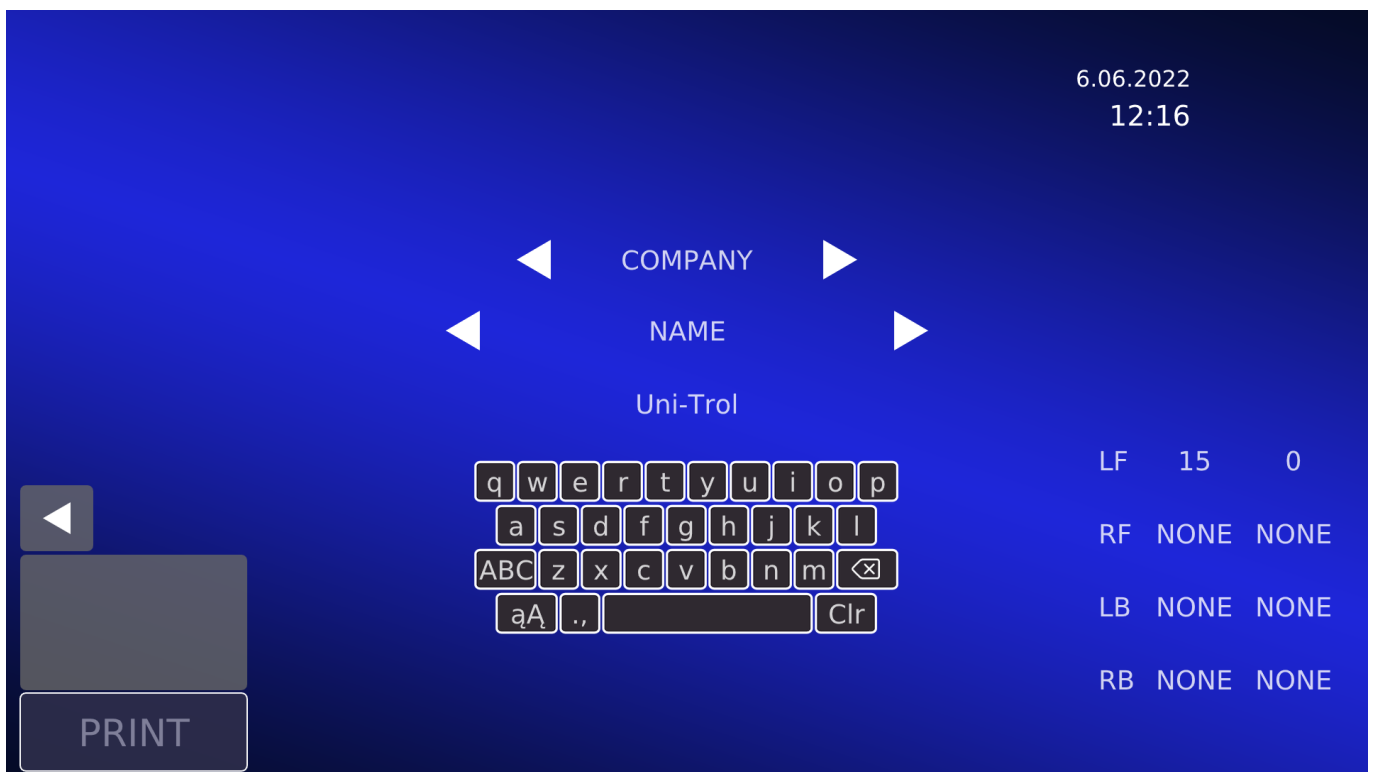
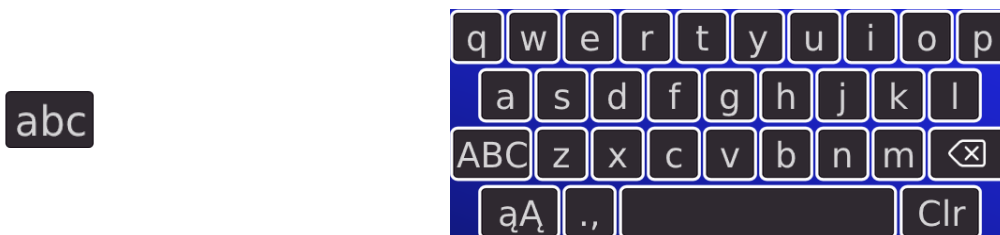

Fig. 36: Sample screen for printing

To fill in the data place the cursor on the keyboard and press the green button. The cursor changes size and will be positioned over the key **q**. Use the wheel to move the cursor to the letter you want and confirm by pressing the green button. To change the keyboard use the buttons described in the table below. The keyboard layout is shown for each button.



ABC



ąĄ



.,

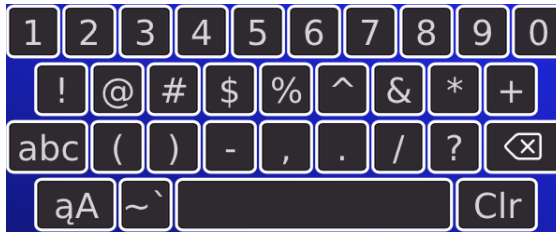

~`



After completing the data press the button **PRINT** to prepare the report. Depending on the selected settings, the printout will be copied to the previously connected USB mass storage device or sent to the printer. One of the following messages will appear above the button in the gray field:

Printout sent	Successful sending of the printout.
Pendrive not connected	No device connected (option TO FILE).
Out of space	No available memory space, memory in read-only mode or memory damaged (option TO FILE).
Copy error	Error copying the report to the USB memory (option TO FILE).
Print error	Report preparation error.
Printer error	Communication error with the printer, no printer connected (option PRINTER)

MAINTENANCE AND SERVICE

- Keep the parts of the balancer handle clean. It is an element that fits very precisely. It should be wiped off any dirt daily, if necessary gently sanded with fine sandpaper. Lightly oil it. A dirty handle may cause jamming of the centering cones and poor indications of unbalance.
- Keeping the machine clean.
- In machines powered by compressed air, make sure that it is drained.
- Periodically add oil to the lubricator (if present in the machine).
- Calibrate the machine periodically.



ATTENTION: Do not blow air at the ultrasound sensors on the housing.

FAULT CAUSES AND THEIR ELIMINATION

FAULT	POSSIBLE CAUSE	FAULT ELIMINATION
After starting the machine the switch is off, the monitor does not display anything.	No power, damage to the electrical system.	Check the fuse and that all electrical connections are in good condition.
Wheel hood does not close / opens	No compressed air in the system.	Check is the compressor on and operating properly
Hood malfunction	Calibration error.	Calibrate hood as described in the Calibration and Hood Tests section
Incorrect readings at different wheel mountings.	Incorrect centering, contamination of the cone and/or spindle, worn centering cone, damaged nut, damaged handle (impact).	Change the centering method, clean dirty elements, replace the cone, replace the nut, replace the handle.

It is always recommended to contact our service.

SCRAPPING

If the device is scrapped, all electrical, electronic and plastic components should be removed from it, and the rest should be scrapped as steel scrap.

Electrical materials (wires) can be scrapped as copper scrap.

WHEEL BALANCING MACHINES RIM STRAIGHTENING MACHINES TYRE CHANGERS EQUIPMENT FOR TYRESHOPS

Statistic no. : 008132994 EC VAT no. : PL5270205246 Register no. : KRS 0000111731 EORI no. :

PL527020524600000

Account : for EURO : ALIOR BANK SA for EURO: no. PL 96 2490 0005 0000 4600 4784 6179 (swift code: ALBPPLPW)



EC Declaration of Conformity

in accordance with directives : 2006/42/EC, 2014/35/EU, 2014/30/EU, 2011/65/EU

We : **Uni-trol Co. Ltd.**
 Ul. Estrady 56
 01-932 Warsaw
 Poland

declare, under our exclusive responsibility, that the product

Wheel balancing machine

Electromechanical device

Models: TROLL 2451 USG

TROLL 2451 L

TROLL 2451 LP

24/7

Serial number

concerned by this declaration, complies with all relevant requirements of the Machinery Directive:

- **Directive 2006/42/EC (safety machines),**

applicable in the essential requirements and relevant conformity assessment procedures, as well as on the essential requirements of the following directives:

- **Directive 2014/35/EU (the low voltage);**

- **Directive 2014/30/EU (the electromagnetic compatibility);**

- **Directive 2011/65/EU (ROHS).**

In order to verification of compliance with the applicable legal regulations have been consulted harmonized standards and other normative documents:

PN-EN ISO 12100:2012P

Safety of machinery -- General principles for design -- Risk assessment and risk reduction

PN-EN 61000-6-3:2008P

Electromagnetic compatibility (EMC) -- Part 6-3: General standards -- Emission standard for environments: residential, commercial and light industrial

PN-EN 61000-6-4:2008P
Electromagnetic compatibility (EMC) -- Part 6-4: General standards -- Emission standard for industrial environments
PN-EN ISO 13857:2010P
Safety of machinery - Safety distances to prevent hazard zones being reached by upper and lower limbs
PN-EN 349+A1:2010P
Safety of machinery - Minimum gaps to avoid crushing of parts of the human body
PN-EN 60204-1:2010P
Safety of machinery -- Electrical equipment of machines -- Part 1: General requirements
PN-EN 61293:2000P
Marking of electrical equipment with ratings related to electrical supply -- Safety requirements
PN-EN ISO 11201:2012P
Acoustics -- Noise emitted by machinery and equipment -- Determination of emission sound pressure levels at a work station and at other specified positions in an essentially free field over a reflecting plane with negligible environmental corrections
PN-EN ISO 11202:2012P
Acoustics -- Noise emitted by machinery and equipment -- Determination of emission sound pressure levels at a work station and at other specified positions applying approximate environmental corrections
PN-EN ISO 4871:2012P
Acoustics -- Declaration and verification of noise emission values of machinery and equipment
PN-EN 50581: 2013-03
Technical documentation evaluation of electrical and electronic products, taking into account Restriction of Hazardous Substances
PN-EN 50419:2008P
Marking of electrical and electronic equipment in accordance with Article 11 (2) of Directive 2002/96/CE (WEEE)
PN-EN 61190-1-3:2008E
Materials for connecting electronic components -- Part 1-3: Particular requirements for solders for electronic applications and solders with fluxes or without fluxes for soldering electronic components .
PN-EN 61760-1:2006E
Surface mounting technology -- Part 1: Method qualification standard components for surface mount (SMD)

The technical documentation of this device, referred to in point 1 of Annex VII A of the Machinery Directive, is located in the headquarters Uni-trol Ltd. (address as above) and will be made available to the competent national authorities for at least 10 years after the last piece.

The person responsible for the preparation of the technical documentation of the product and introducing changes in it, is MSc. Gregory Tworek.

This EC Declaration of Conformity will be kept by the manufacturer of the product for 10 years from the date of produce the last unit and will available for market supervisory authorities for verification.

MSc. Gregory Tworek

Warsaw, 19.07.2021

.....
Signature