

PARTI DI RICAMBIO

SPARE PARTS
PIÈCES DE RECHANGE
ERSATZTEILEN
REPUESTOS
ЗАПАСНЫЕ ЧАСТИ

SMONTAGOMME

TYRE CHANGING MACHINE
DÉMONTE PNEUS
REIFENWECHSLER
DESMONTA-NEUMATICOS
ШИНОМОНТАЖНЫЙ СТАНОК

N° 102150 REV. 7
N° 101513 REV. 8
N° 102733 REV. 6
N° 101512 REV. 11
N° 101066 REV. 5
N° 102151 REV. 5
N° 102152 REV. 3
N° 101518 REV. 4
N° 101514 REV. 6
N° 101071 REV. 5
N° 101515 REV. 6
N° 101045 REV. 13
N° 100080 REV. 1
N° 100078 REV. 0
N° 100142 REV. 1
N° 100183 REV. 0

FALCO AL518 - AL520

e versioni speciali

and special versions - et versions spéciales - und Sonderausführungen

y versiones especiales - И МОДИФИКАЦИИ

IT - ASR - ITS - ITASR - ITE - RACING - ITE RACING

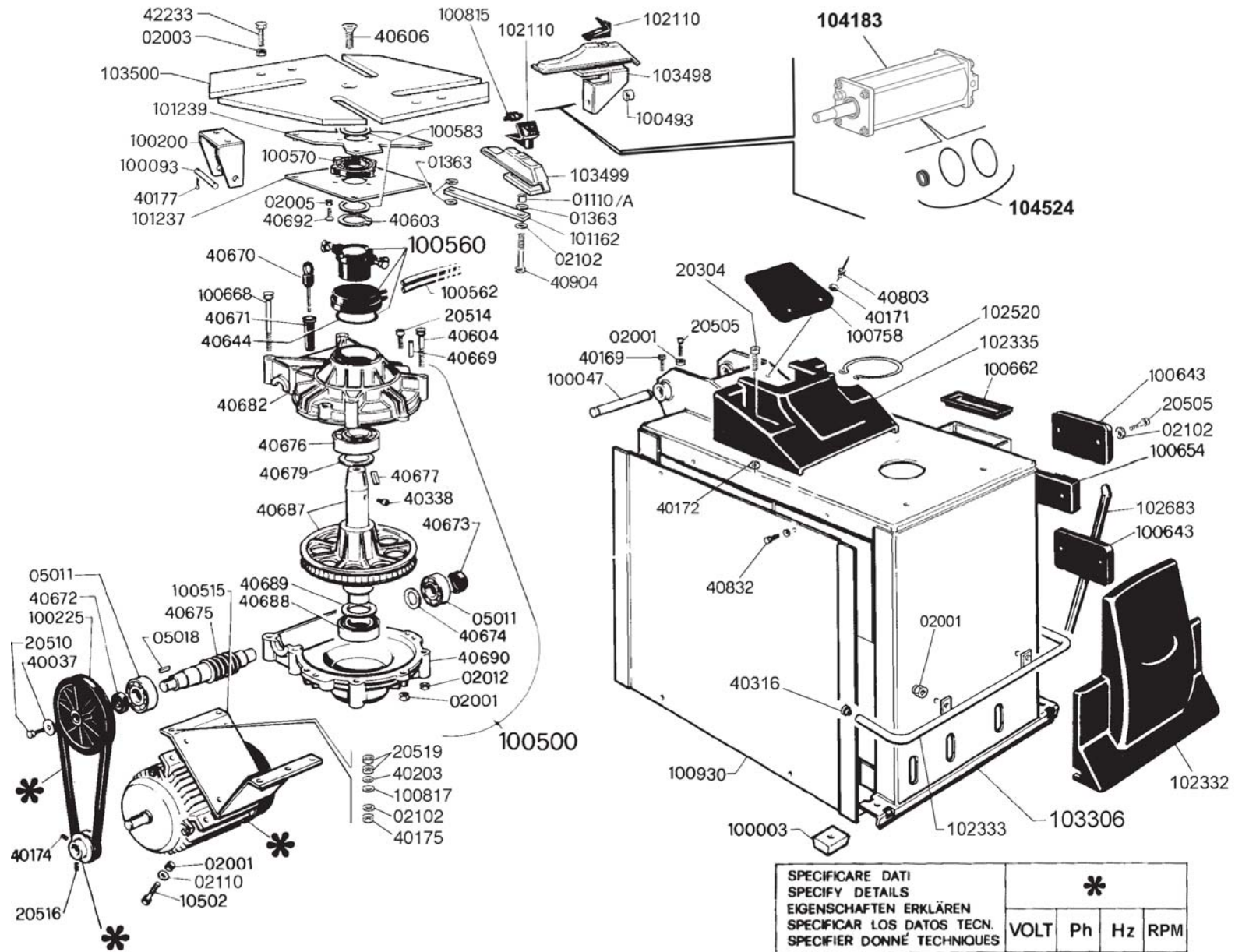

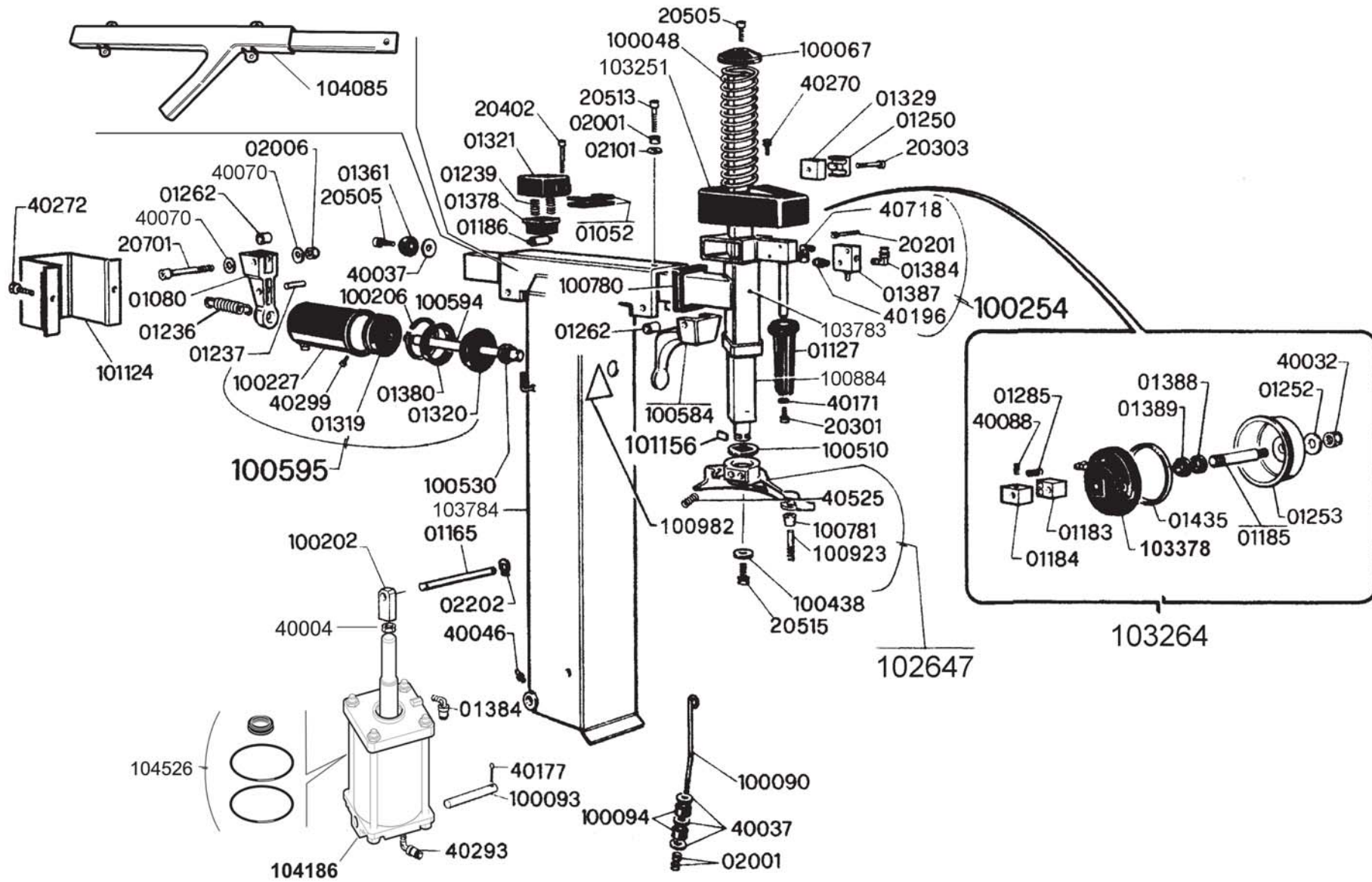

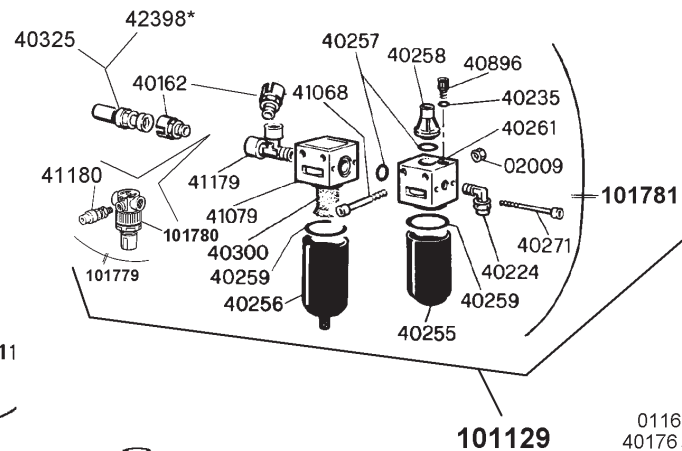
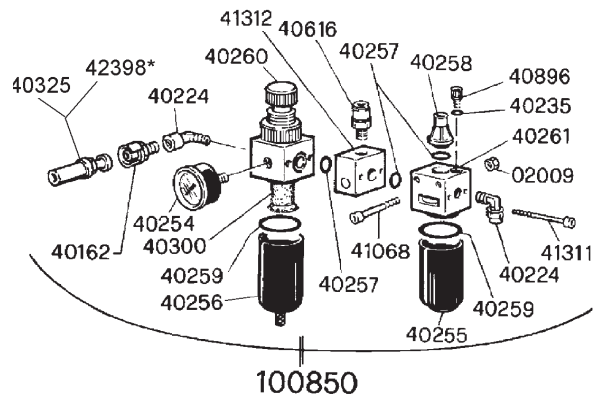
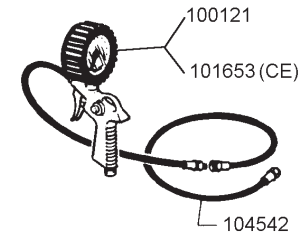
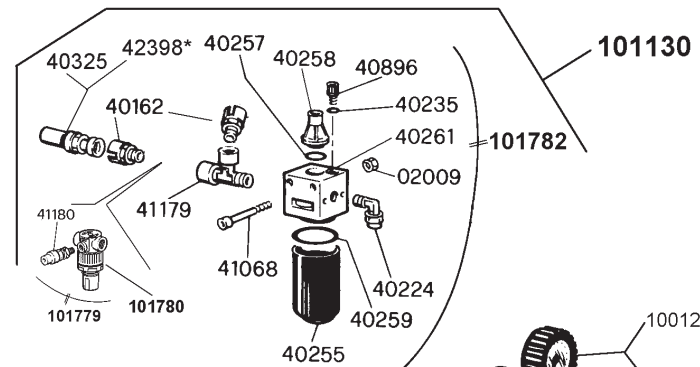
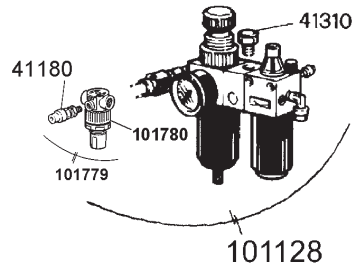
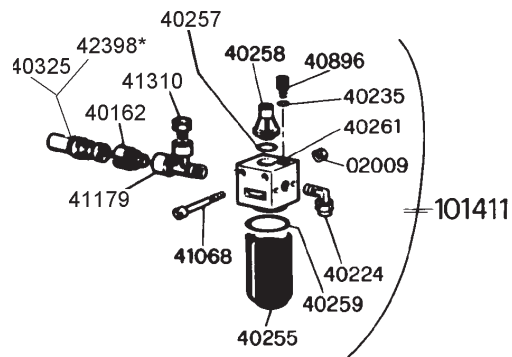

101129

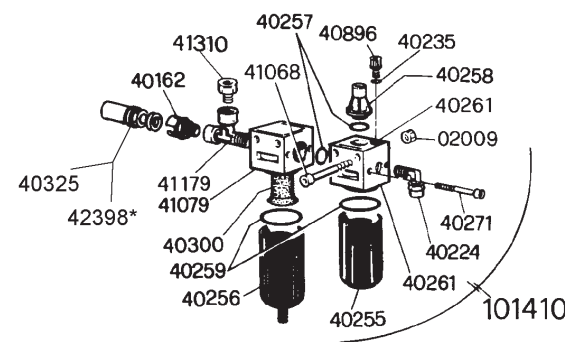
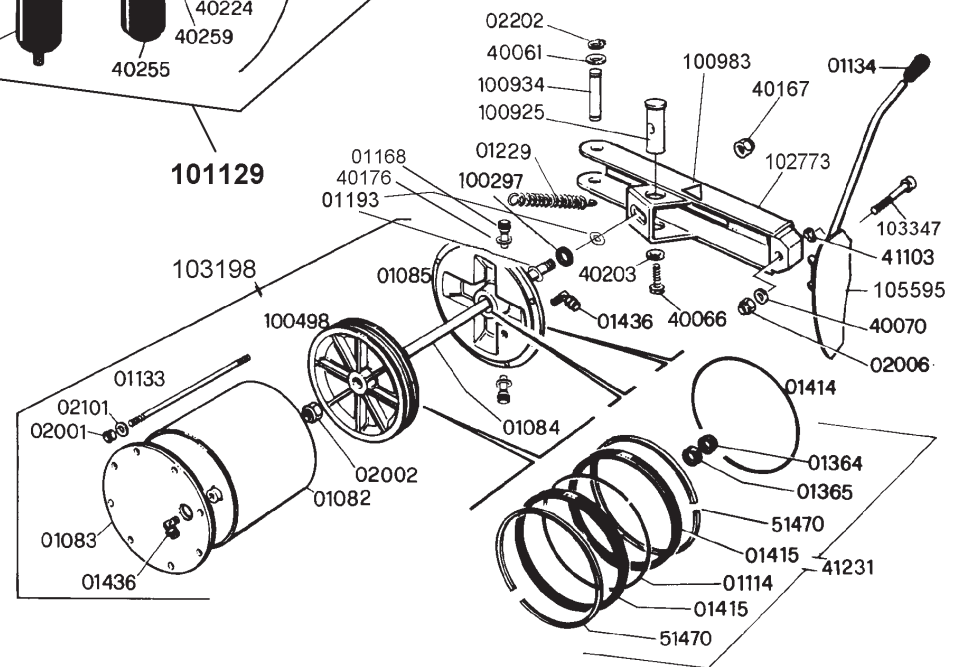
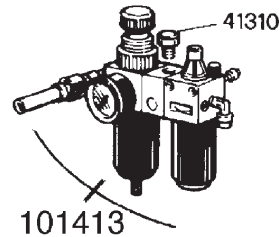

* only for Germany

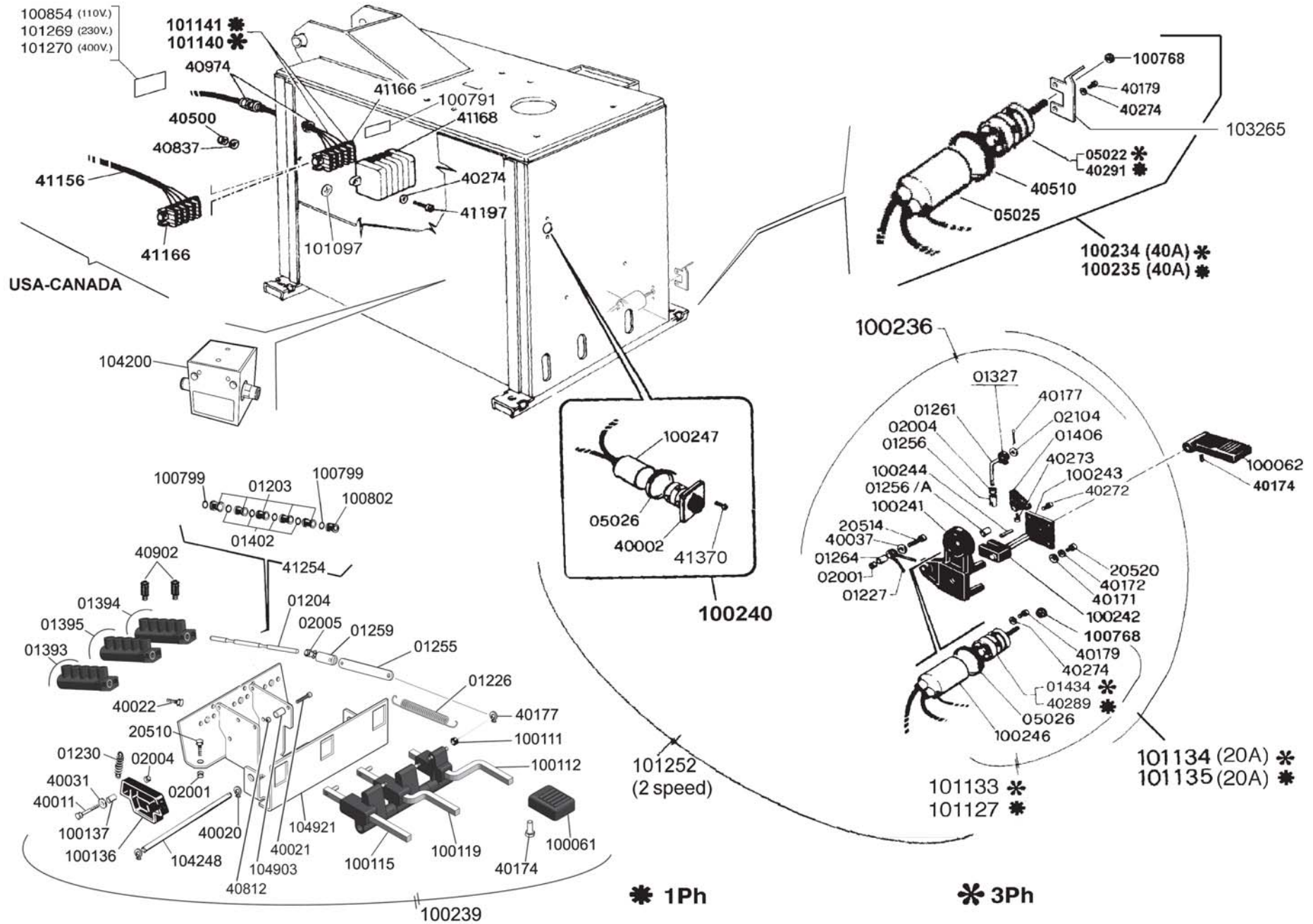

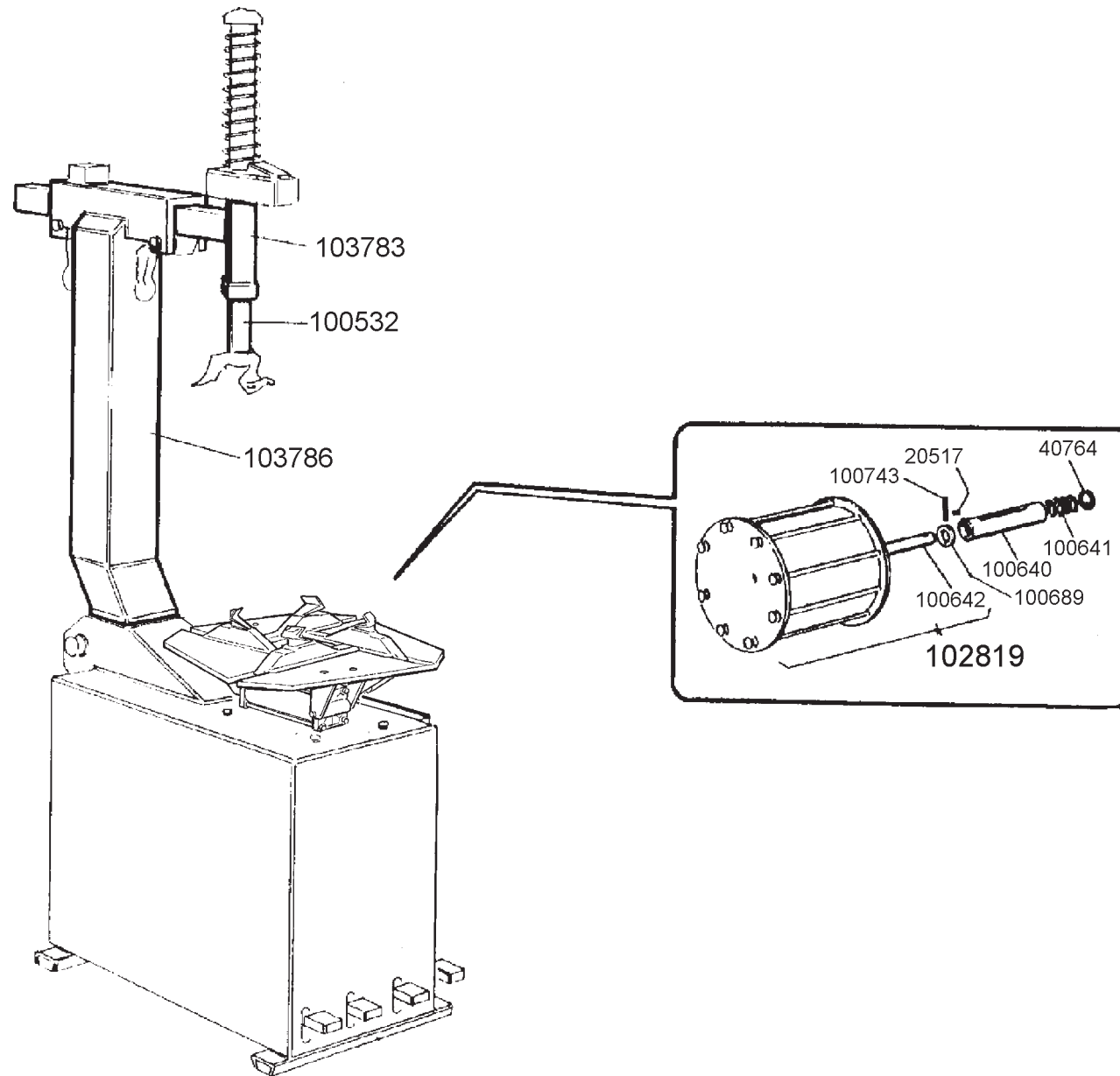

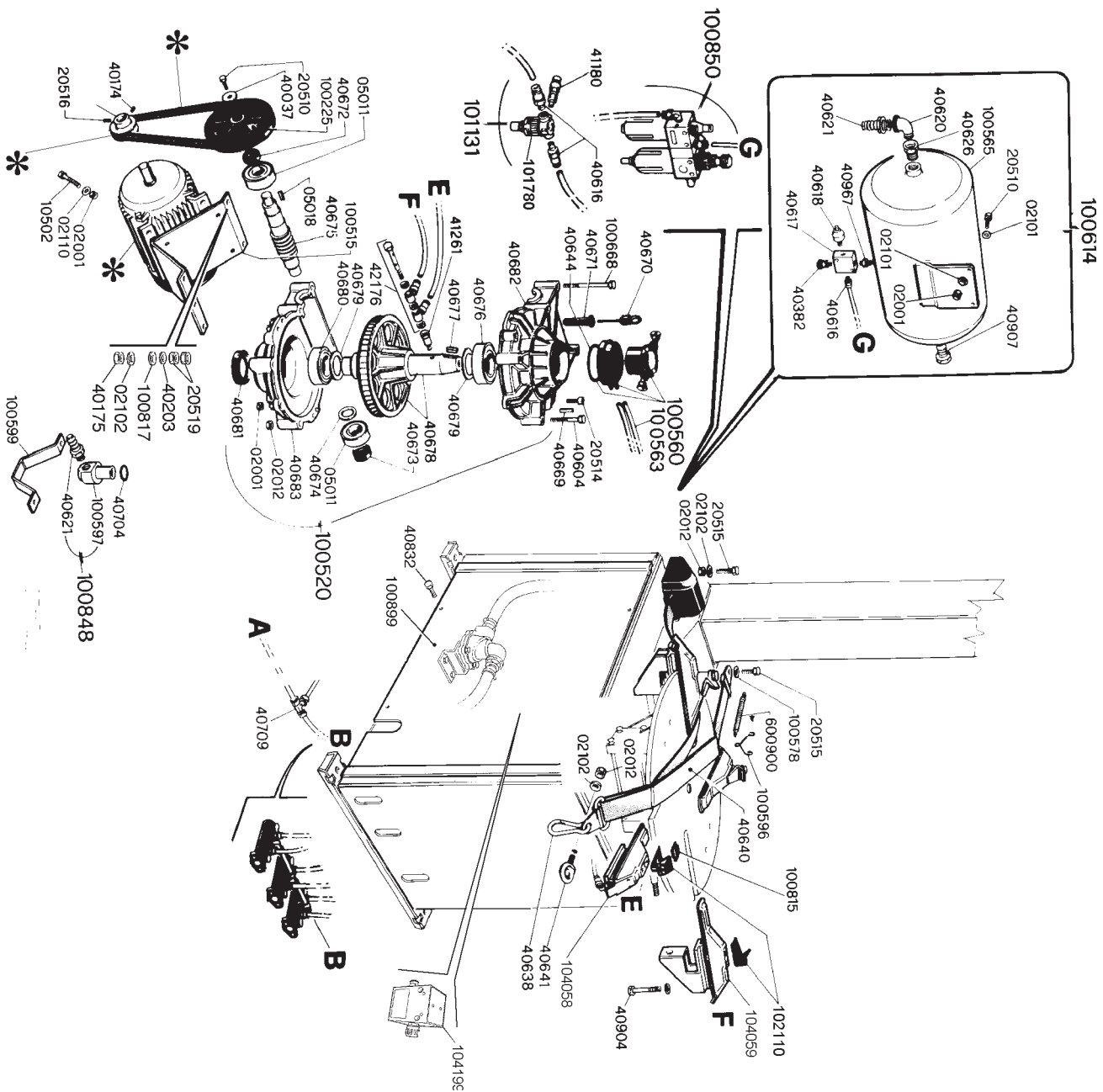

SPECIFICARE DATI SPECIFY DETAILS EIGENSCHAFTEN ERKLÄREN SPECIFICAR LOS DATOS TECN. SPECIFIER DONNÉES TECHNIQUES	*	VOLT	Ph	Hz	RPM
---	---	------	----	----	-----



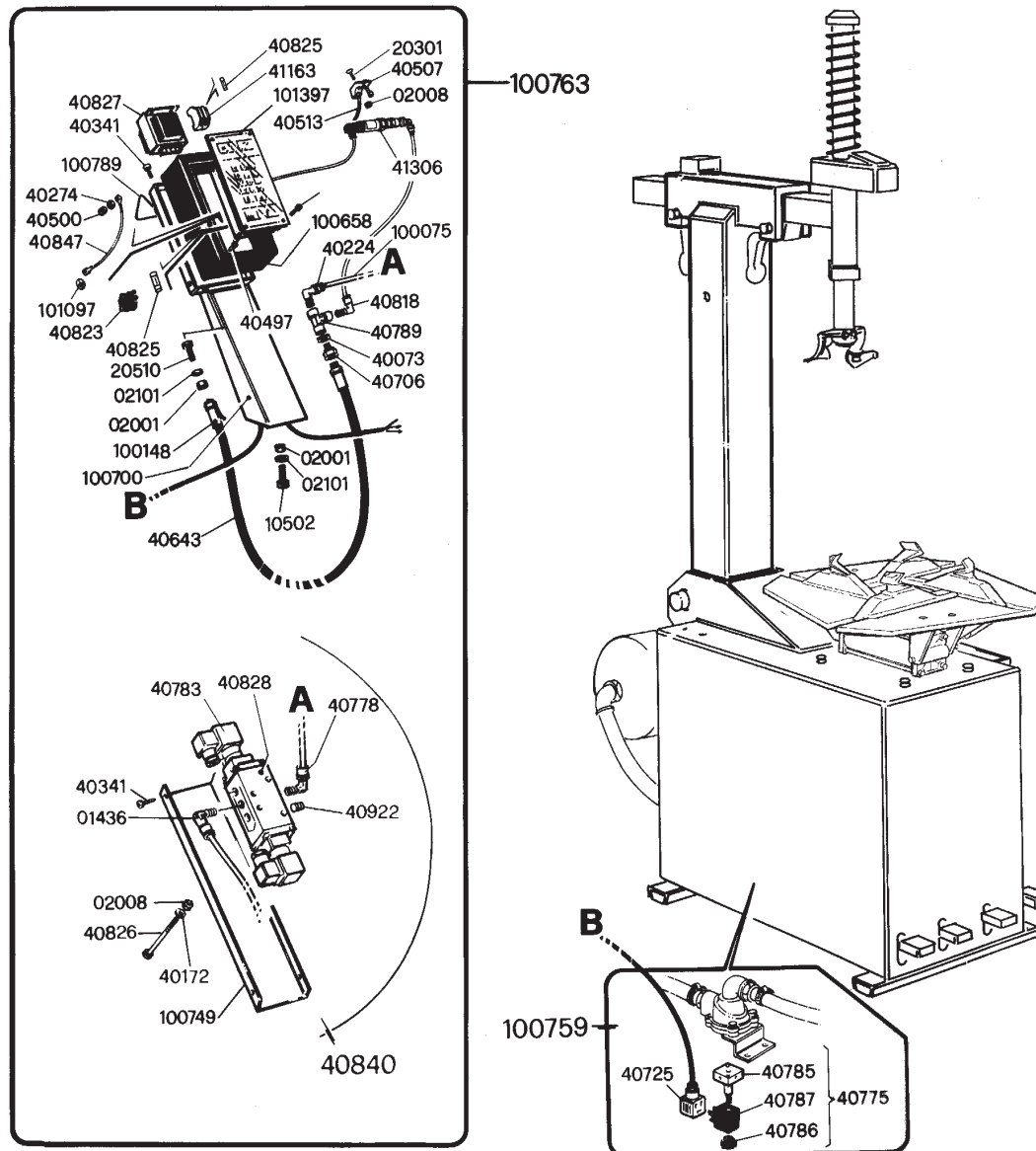

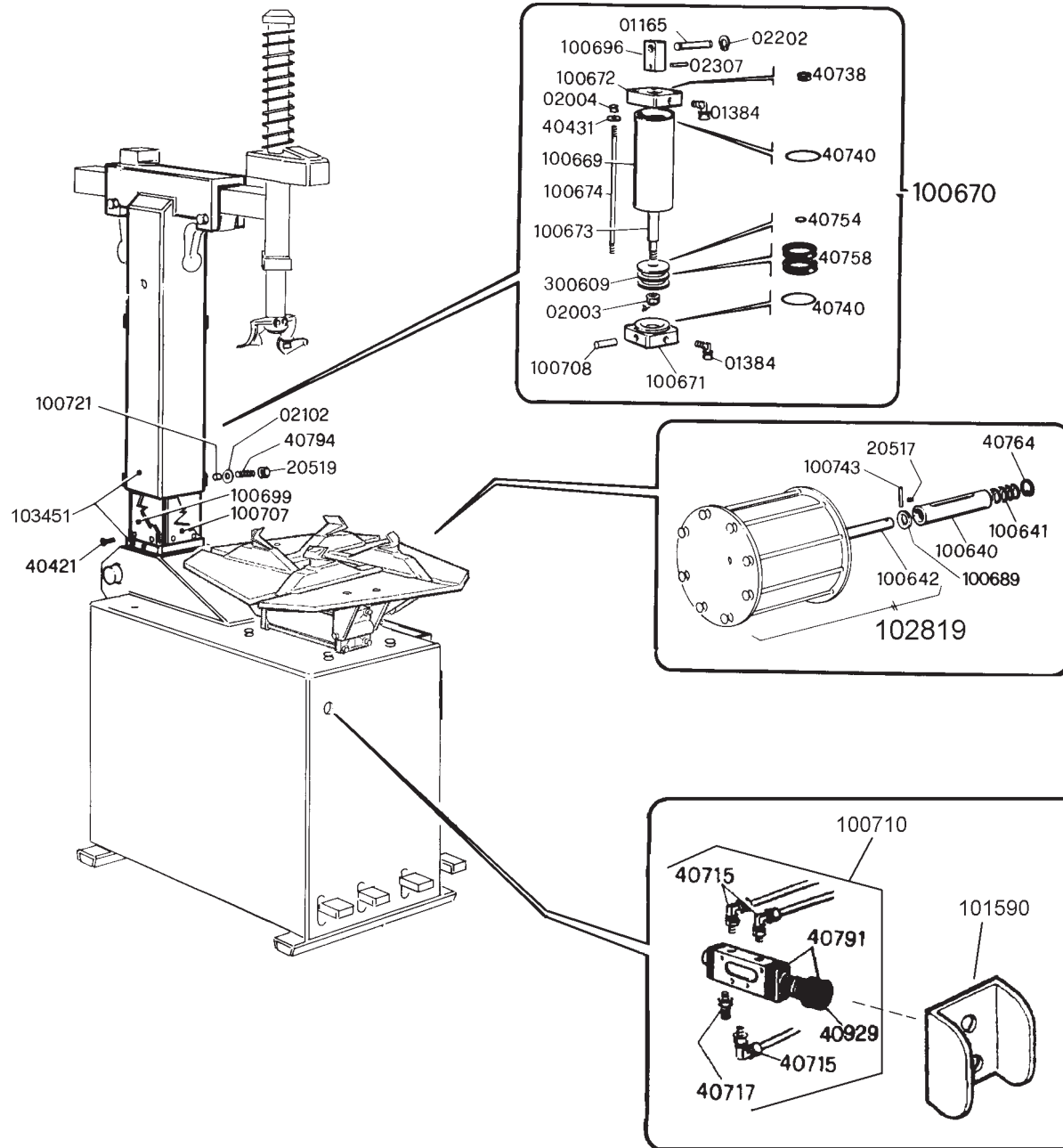

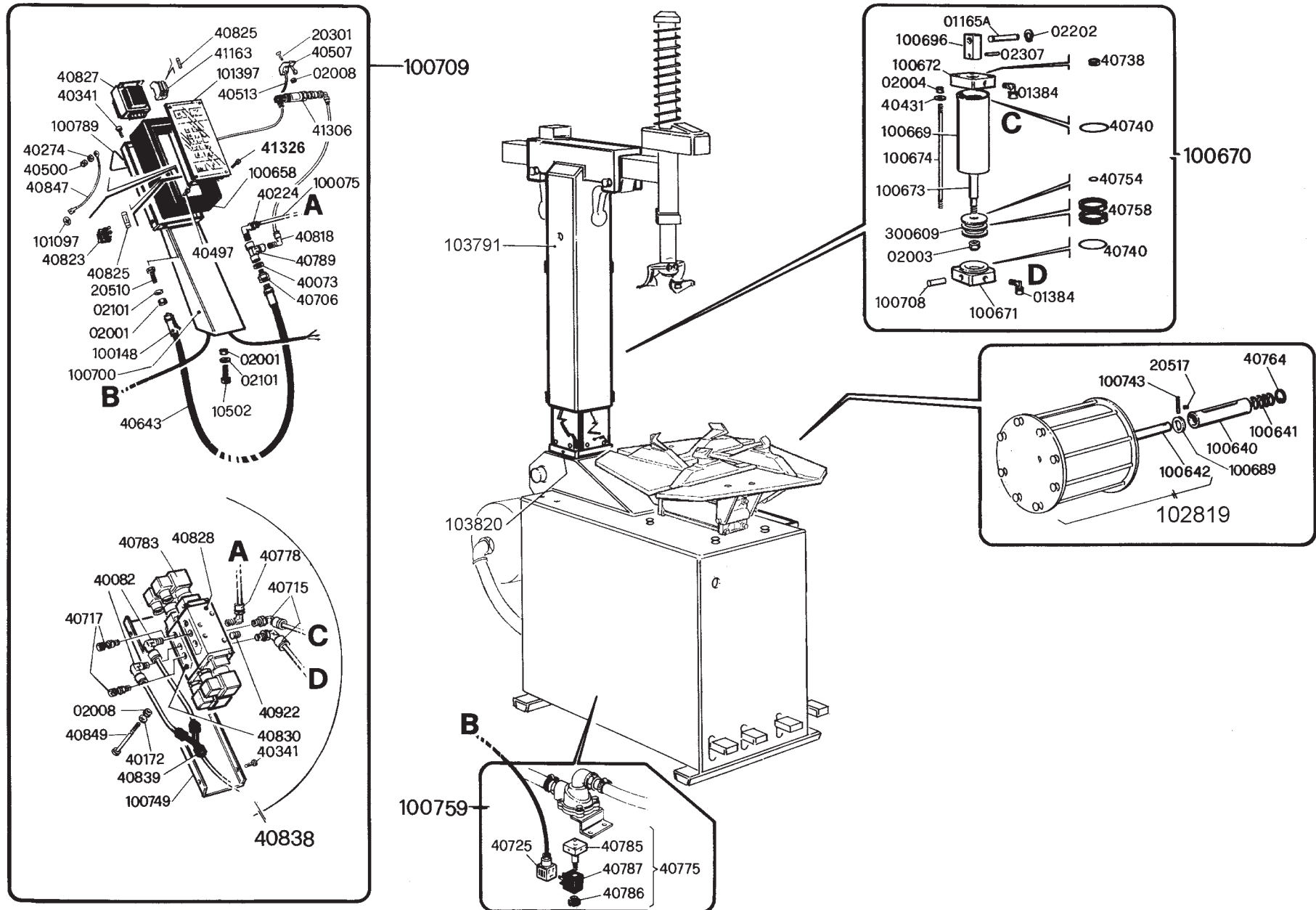

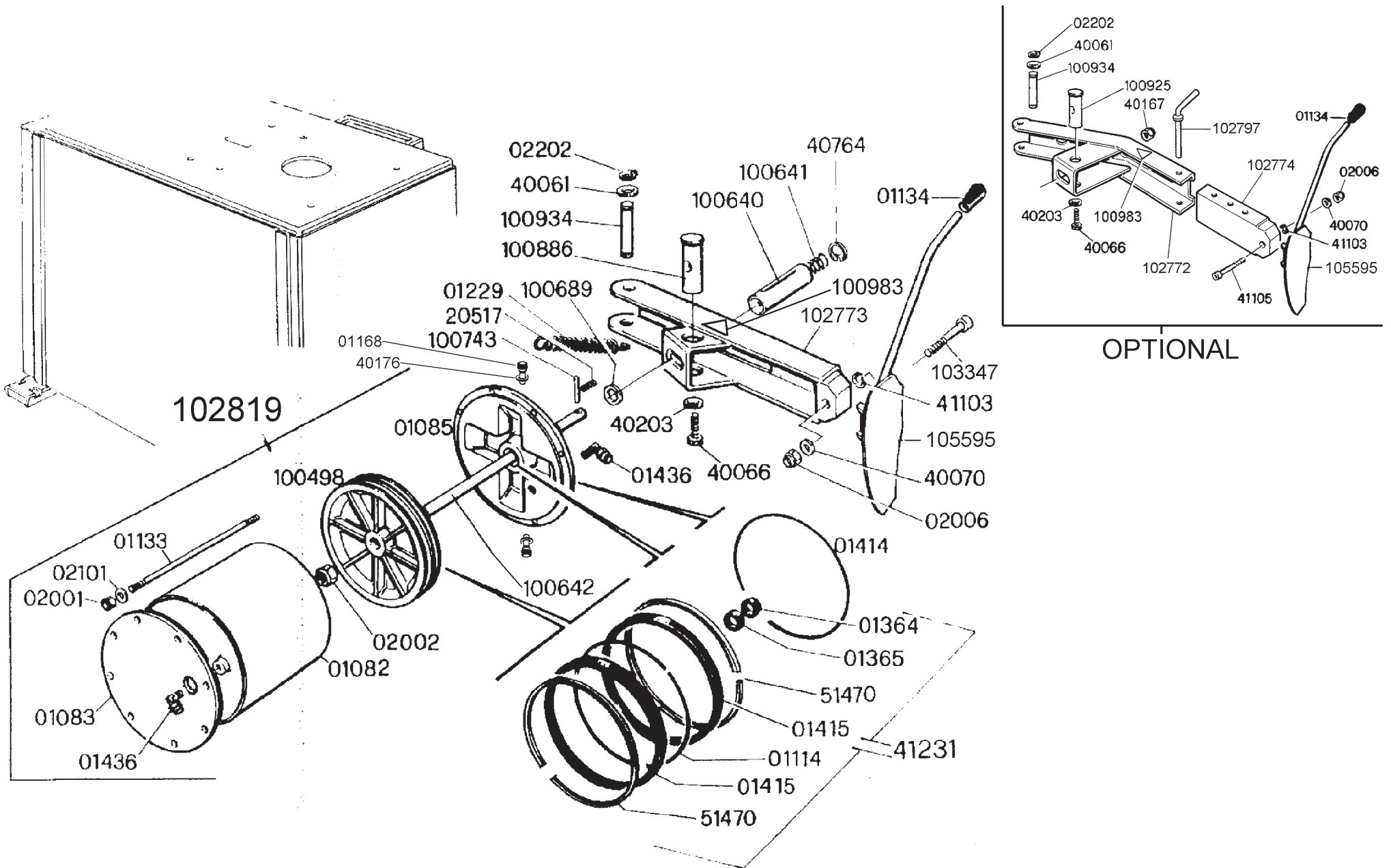

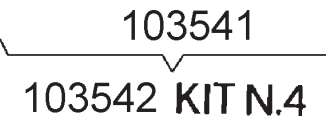
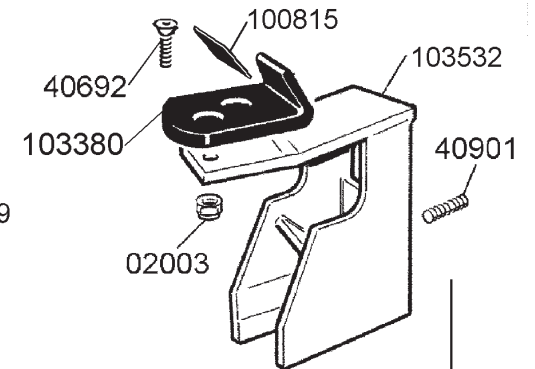
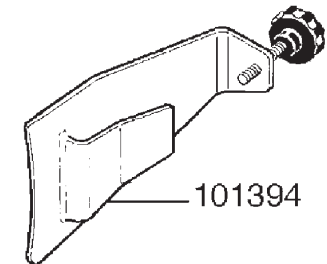
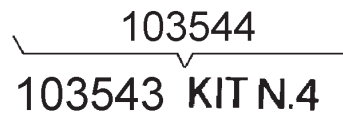
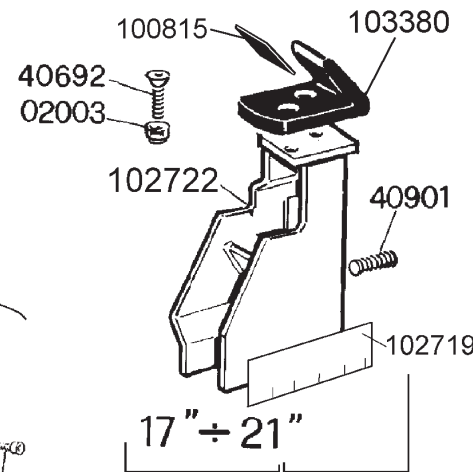
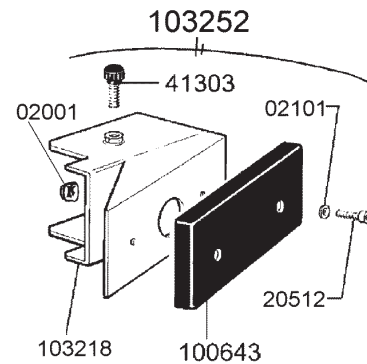
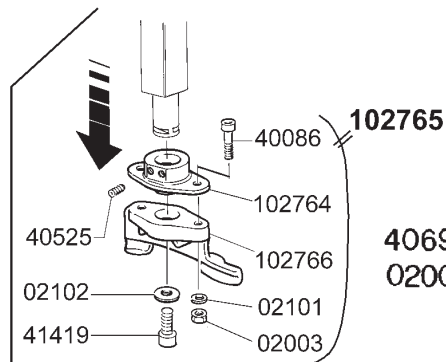
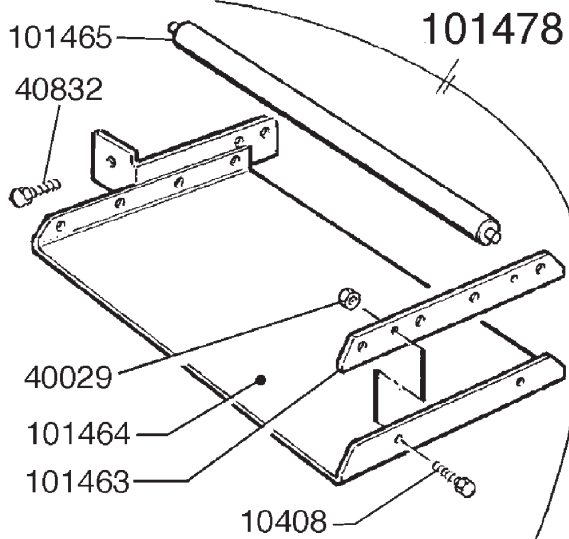
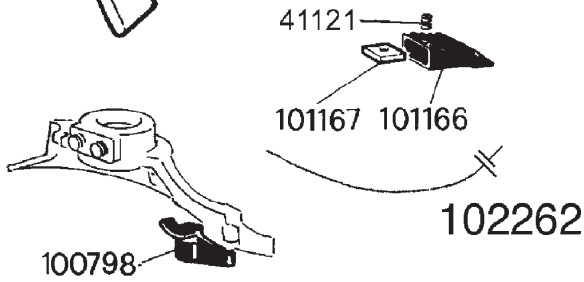
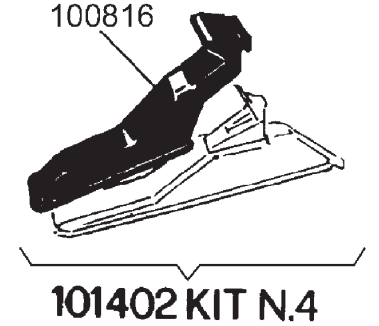
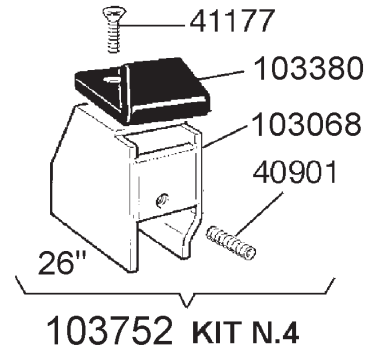
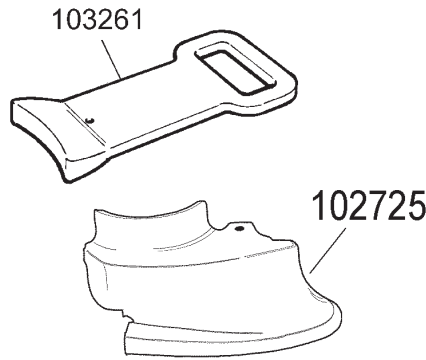
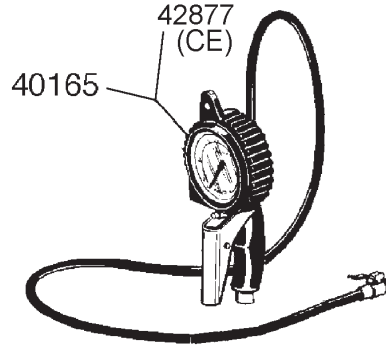
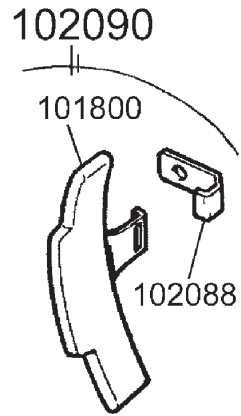

MONTAGGIO GRUPPO
A RICHIESTA FR+L+
Valv.TAR 3,5 BAR

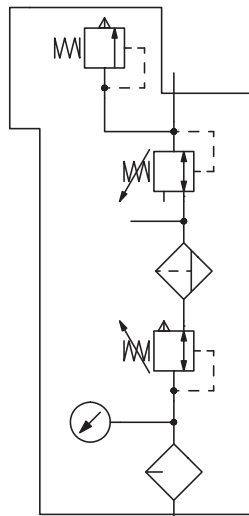

PRESSIONE DI ESERCIZIO
DA 1.5 A 12 BAR

MONTAGGIO GRUPPO A RICHIESTA

AUTOCENTRANTE

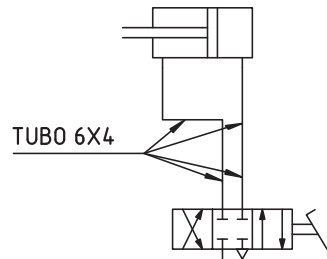

STALLONATORE

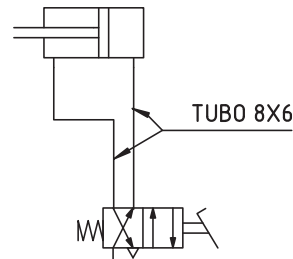

RIBALTAMENTO PALO

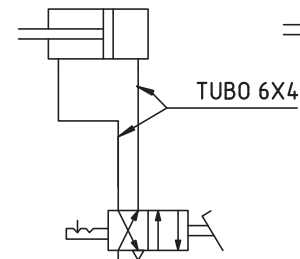

VERTICALE

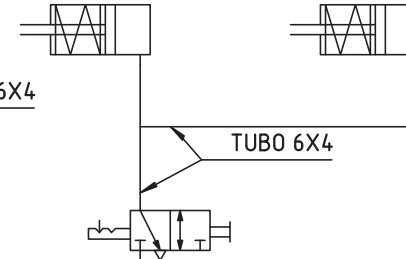

BLOCCAGGIO

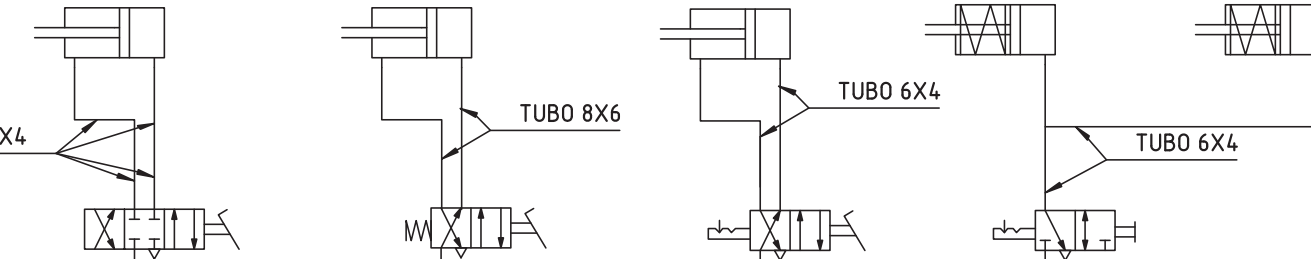

PRESSIONE DI ESERCIZIO
DA 1.5 A 12 BAR

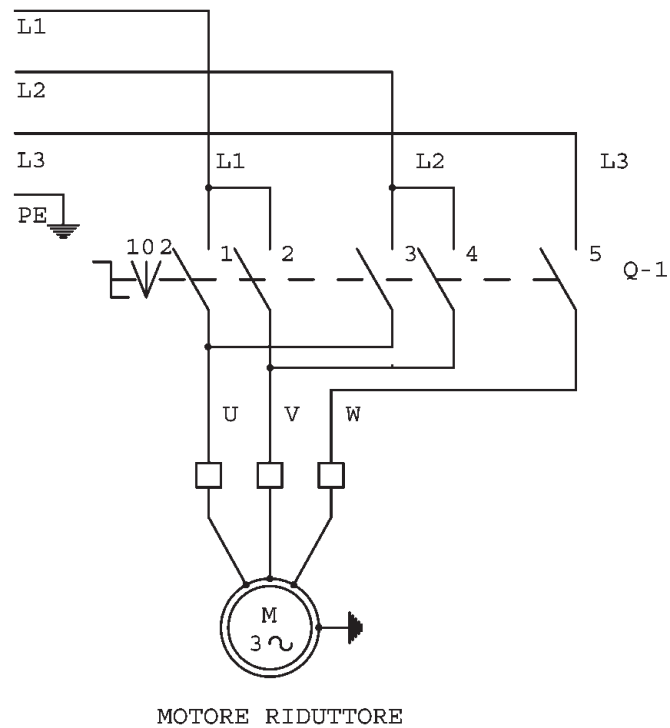

Q-1

	X	X		X		2	POS.	
						0		
X			X	X		1		
1	2	3	4	5	6	CONT.		
I	II	III	ELEM.					

1-ROTAZIONE ORARIA

2-ROTAZIONE ANTIORARIA

DISEGNO : 100078	DATA	DIS
	21/11/02	PEL
3 Ph - 1 speed		

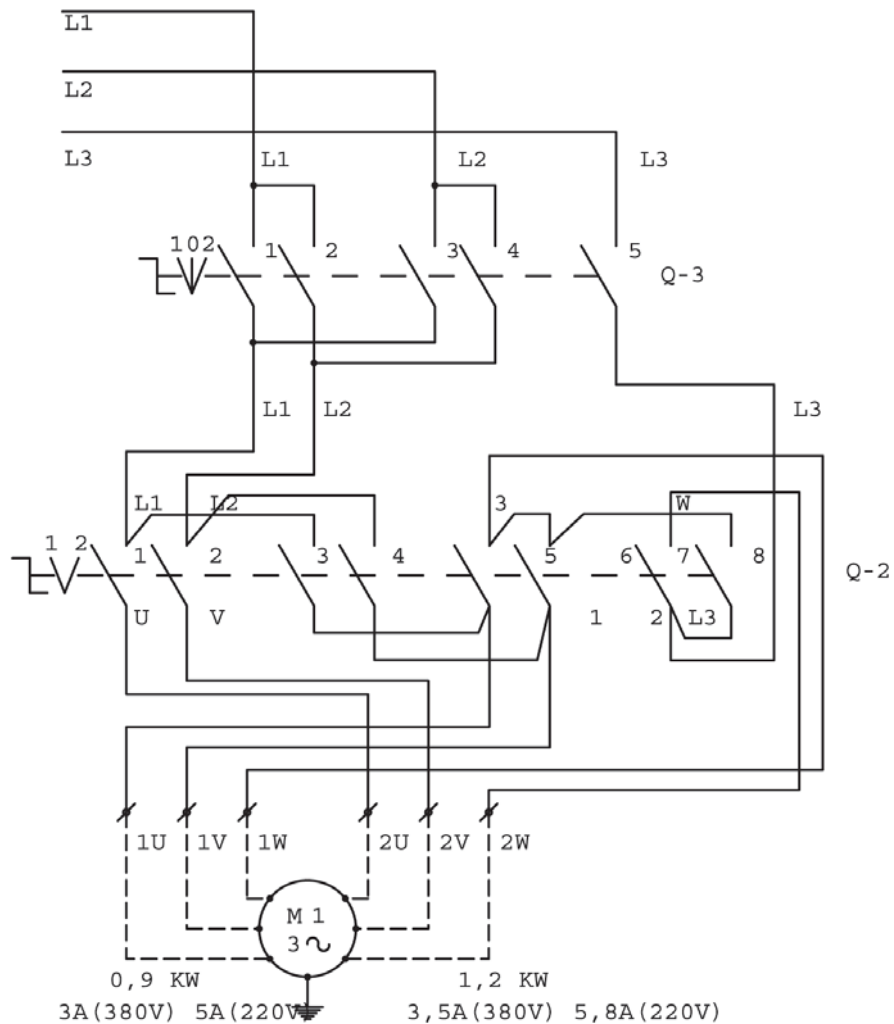

Q-3

ELEM.	I	II	III
CONT.	1 2 3 4 5 6		
POSIZ.	1 X	X X	X X
	0		
	2 X X	X	X

Q-2

ELEM.	I	II	III	IV
CONT.	1 2 3 4 5 6 7 8			
POSIZ.	1	X X		X
	2 X X		X X X	

DISEGNO : 100142	DATA	DIS
	26/03/03	PEL
3 Ph - 2 speed		

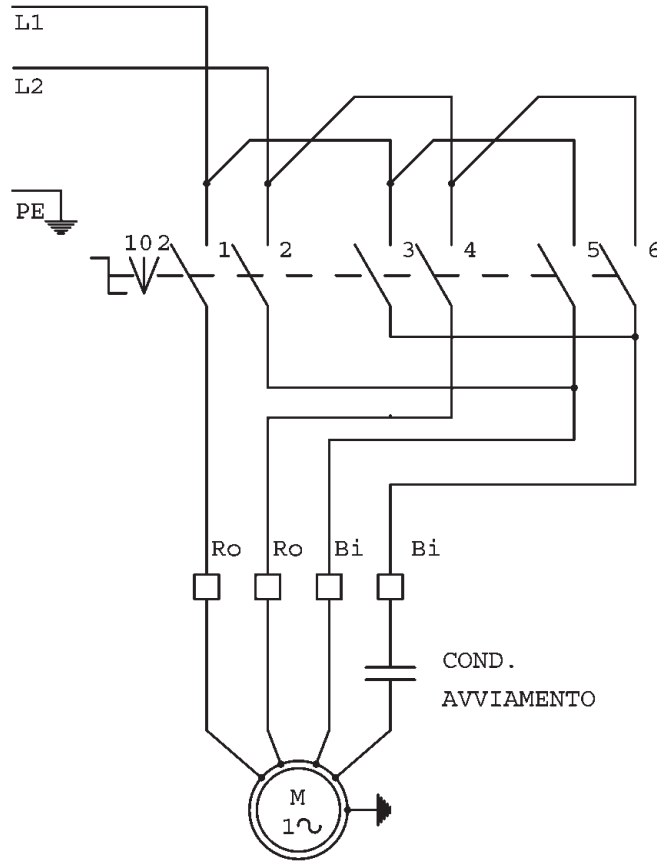

Q-1

Q-1

X			X	X	X	2	POS.
						0	
X	X	X	X			1	
1	2	3	4	5	6	CONT.	
I	II	III	ELEM.				

1-ROTAZIONE ORARIA

2-ROTAZIONE ANTIORARIA

MOTORE RIDUTTORE

DISEGNO : 100183	DATA	DIS
	21/11/02	PEL
1 Ph - 1 speed		



SICAM S.r.l.

Via della Costituzione 49

42015 Correggio (RE) ITALY

Tel. +39 0522 643311

Telefax: + 39 0522 637760

<http://www.sicam.it>

sales@sicam.it