

TYRE CHANGER

USER MANUAL

Pls read this manual before operation

Indication:



Danger: The chuck arm and mechanical arm may rotate to cause the damage and injury!



Danger: The wheel may drop off to cause the damage and injury!



Danger: Tool head may rotate to cause the damage and injury!



Danger: The chuck arm may rotate to cause the damage and injury!



Danger: Electrical shock to cause the damage and injury!

Content

Warning.....	II
Technical Parameter.....	1
Feature and applied scope	1
Accessory.....	1
Installation	
Unpacking, transportation and location.....	3
Electrical connect and running.....	4
Safety protection label.....	5
Operation and Structure.....	6
Installation and commission.....	7
Dismount/Mount the wheel.....	8
Troubleshooting analysis and repair.....	10
Maintenance.....	10
Knowledge and notice of the maintenance and repair.....	11
Pneumatic drawing.....	11
Hydraulic drawing.....	12
Electrical drawing.....	13

Thanks for you purchase our products. To use this equipment much better and secure your safety, you must read this instruction manual and keep it well. This manual constitutes an integral part of the products. Please study the warning label and operation instruction carefully. All of these information is very important to the safety operation.

It is the full automatic universal truck tire changer. The movement of all the work parts is controlled by a movable console. It can easily dismount/mount the drop center rim, tubeless wheel and wheel with ring of truck, agricultural vehicle and industrial vehicles especially 14"-56" (Max. wheel diameter is 2300mm and the max. wheel width is 1085mm) . This machine can n=only be used to dismount/mount the tire and not for the other purpose and we will not be responsible for the damage of the machine due to the improper use. Important: The operator should be under the proper training and with the knowledge of mechanical, electrical, hydraulic and pneumatic.

Warning! We must dismount/mount after the wheel is completely deflated !

Warning! It is prohibited to inflate the wheel when mounted on the machine !

Warning! It needs at least 2person to move the especially heavy tire !

Warning! The installation and commission of all the electrical/ pneumatic/ hydraulic parts must be operated by the professional technicians.

Warning! You should purchase the wearable spare parts from the dealers or manufacturer to guarantee the original parts. And the manufacturer does not promise to repair the damage due to the abnormal operation free of charge.

Technical parameter:

Overall dimension

L2100~2600 mm

W1900 mm

H870~1750 mm

Weight

NW987kg

GW:1252kg

Dual speed gearbox

Speed:1430r/min 2870r/min

Power2.4/3kW

Phase3

Power supplyAC 380V

Noise.....≤75 db

Hydraulic motor

Power1.1 kW

Power supplyAC 380V

Air pressure min/max... 8-10 bar



Applied scope

Rim clamp range \sum 14 " ~ 42 "

Clamp ring (optional) \sum 42 ~ 56 "

Max. wheel diameter \sum 2300 mm

Max. wheel width \sum 1100mm

Feature:

1. 4-jaw hydraulic chuck (Fig 1):

It can achieve the dual speed and two way rotation of the chuck. The clamp force can be adjustable.

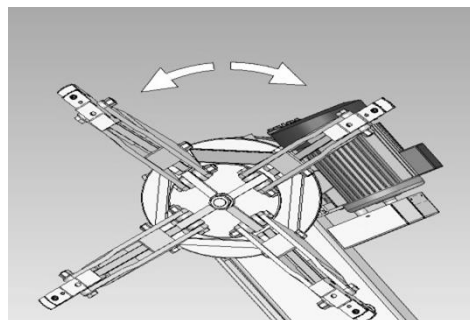

Fig1 4-jaw hydraulic chuck

2. Clamp jaw (Fig 2):

The design of the clamp jaw can secure the safety and reliable of clamp.

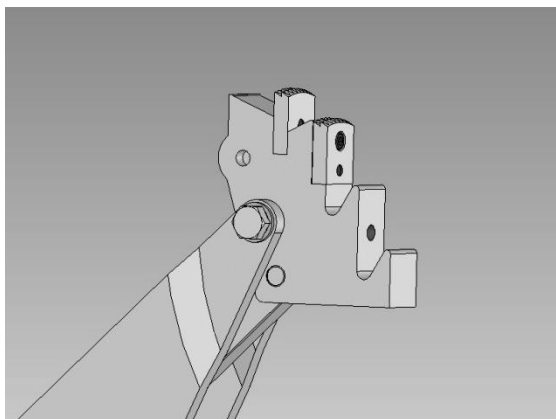

Fig2 clamp jaw

3. Movable console (Fig 3):

It can realize the integrated control the move in all direction.

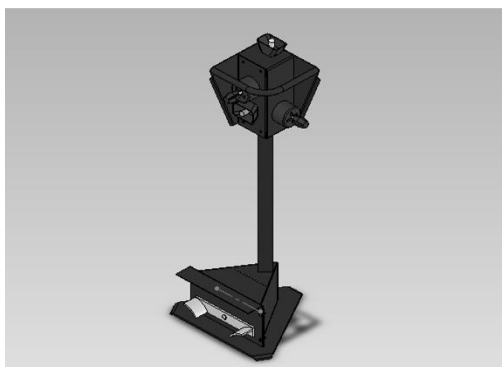

Fig3 Movable console

4 Hydraulic unit (Fig 4):

Meet the clamp force requirement of varied alloy rim. This unit without the pressure protective device.



Fig 4 hydraulic unit

5 Mechanical arm (Fig 5):

It is a quick rotation system can help to complete the detachment of the rim with varied flange from the tire. The tool head can remove the tire.

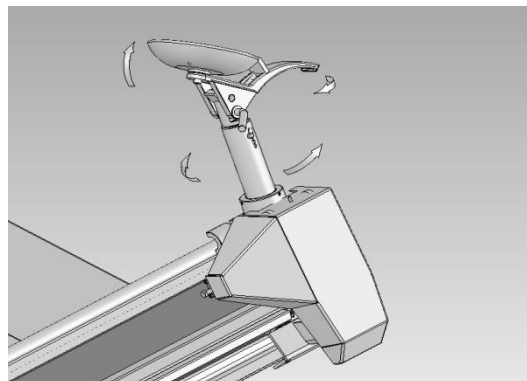

Fig 5 mechanical

Optional:

1 Crowbar (Fig 6):

Detach the stiff tire from the rim.

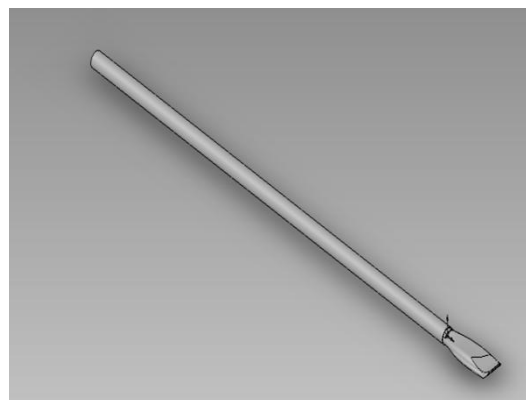

Fig6 crowbar

2 Tire pliers (Fig 7):

It is used to dismount/mount the tubeless tire of the bus.



Fig 7 tire pliers

Optional:

1 Nylon protective jaw, 4pieces (Fig8):

When dismount/mount the aluminum alloy and light metal rim.

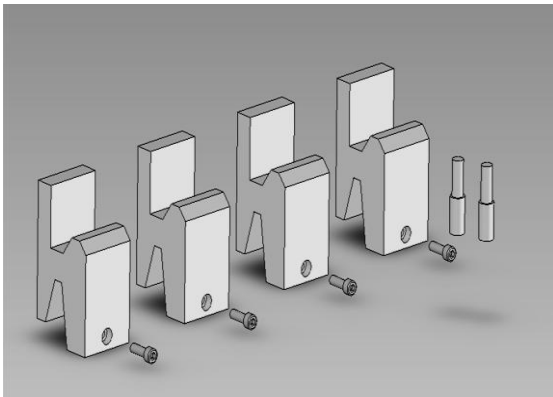

Fig8 nylon protective jaw

2 Rim pliers, 2pieces (Fig 9):

Clamp on the bulge of the rim to separate the tire from the tire.

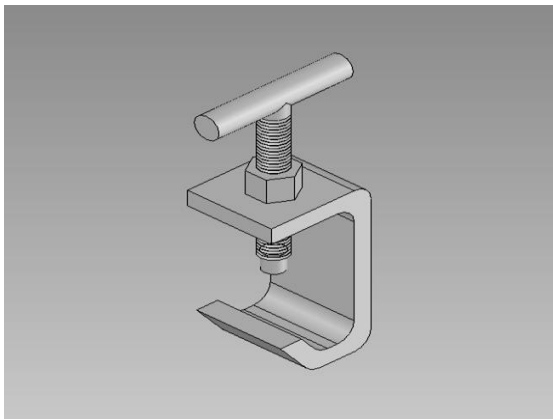

Fig 9 rim pliers

3 Roller. 1piece (Fig 10)

It is used to mount/dismount the tubeless tire of the passenger car.

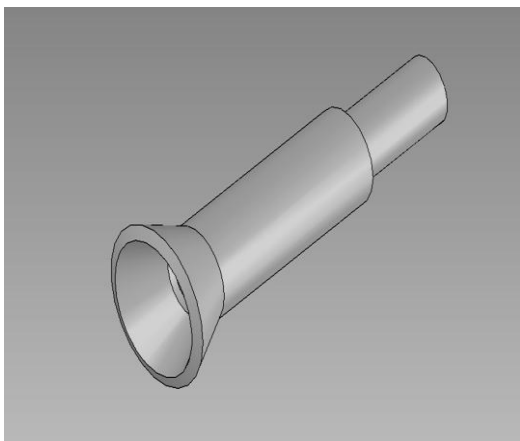

Fig10 roller

4 Crowbar, 1piece (Fig 11)

To detach the retaining ring at the edge of the rim.

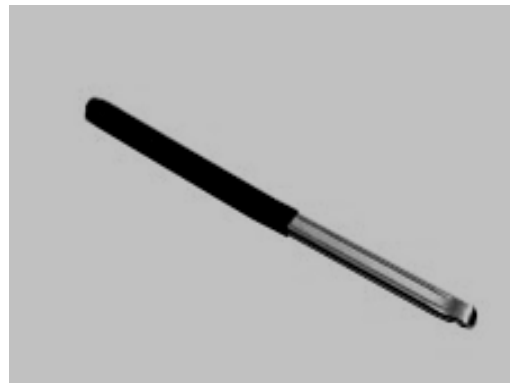

Fig 11 crowbar

5 Extension jaw holder, 4pieces (Fig 12)

When dismount the rim of 42~56 ",you should use this special accessory.

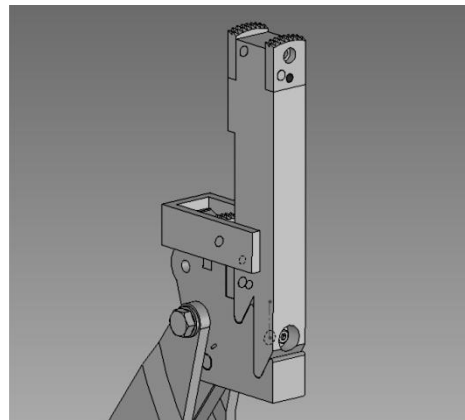

Fig12 extension jaw

Installation methods:

After you get the machine, detach the packing material (be careful when you remove the band). Check if the machine is damaged or some of the parts are lost. If you are doubt of that the machine can not used, please consult the qualified personnel or the agent.

Warning! Packing material (wood, plastic bag, polyethylene board and nail .etc.) should not be placed at the position the children can enter for it is dangerous to the children.



Transportation (Fig 14)

If the place to install is relatively far and need transportation, please do as the following instruction:

A The 2 ropes to hoist, one is 2X1.5m and another is 2X2m and the position to hoist as per Fig14.



Fig 14 transportation way to hoist

B Use the suitable lift machine to lift it. The net weight of the machine is 984kg.

Whenever move the machine, you should care about the safety to meet the condition of hoisting.

15 Hoist method

Overall dimension of the machine (Fig 15):

Max. height.....1750mm

Width.....1900 mm

Max. length.....2600 mm

Safety distance:

To use this machine satisfactory, please leave the suitable space around the machine to move the movable console and keep some distance to secure the safety. See the dimension A, B and C of Fig 15

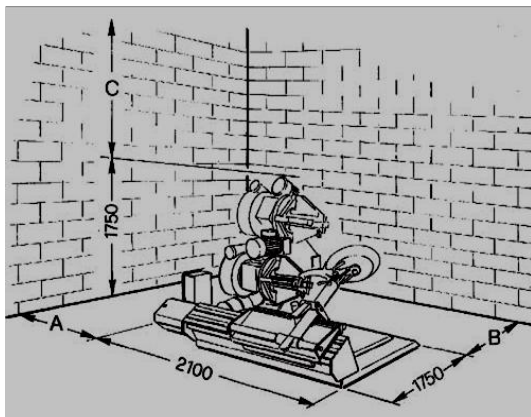

Fig15 overall dimension of machine

Electrical connect and running check (Fig16):

Electrical connect: All the work on the electrical system should be done by the authorized personnel.

Check if the power supply is corresponding with the power supply indicated on the label of the machine.

A Choose the plug in accordance with the local standard and the plug must have the ground terminator.



Fig 16 Electrical connect

B Check if the ground is effective.

C The main circuit of the machine must be applied with the circuit brake switch meet the CE. The distance to connect should be at least 3m.

D Check if the connect of the plug of the cabinet plug is correct (Fig17)



Fig 17 Electrical connect plug

E After connect the circuit of the machine, connect the switch to check if the rotation direction of the hydraulic unit is corresponding with the indication of the No 16.

F If the rotation direction of the oil pump motor is reverse, exchange any two phase at the power plug.

G If the running of the machine is abnormal, you

should immediately switch off the power switch(No 15 in Fig 18) and check the reason of the troubleshooting and repair.

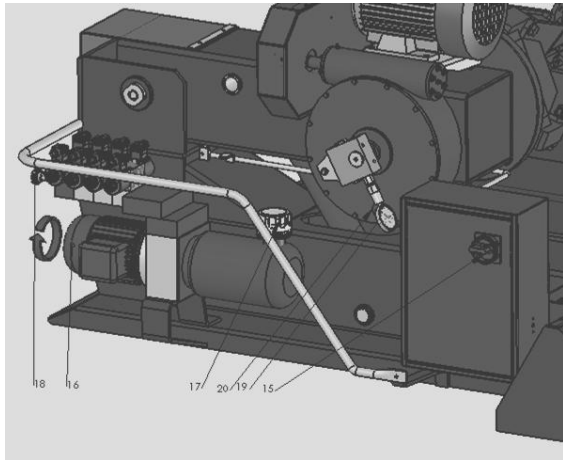

Fig18 Structure A

The manufacturer will not be responsible for the damage due to the above reversal connect of power cable

Safety protection label:

When operate, you should pay attention to the warning label on the machine.



- A Warning the drop off of the wheel;
 - B Warning label at the connect of the mechanical arm
 - C Warning the tilt of the mechanical arm
 - D Warning the electrical shock
- If you lose or damage one or more warning label

above mentioned, you should order the lost warning labels from our company and note the relevant code for repair.

LC590 with the following safety protects:

- 1 Chuck protective sheet (Fig 19)
- 4 metal protection sheets are used to protect the disk inside when the jaws open. Another function of it is to prevent the reach inwards of the human body or the tools.



Fig19 chuck protection sheet



- 2 Chuck protective rubber sheet (Fig20)
- It is used to prevent the reach of the human body or the tools inwards from the rear of the check arm.

Fig 20 chuck protective rubber sheet

- 3 Safety micro-switch (Fig21)
- It is the electrical control device which will stop immediately when the chuck arm drop too much. Warning! You should repair at once when there are troubleshooting and any safety device above mentioned deactivate.

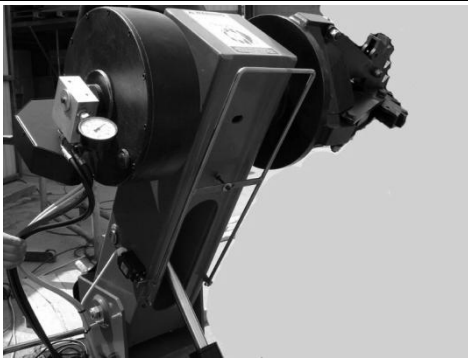

Fig21 Safety micro-switch

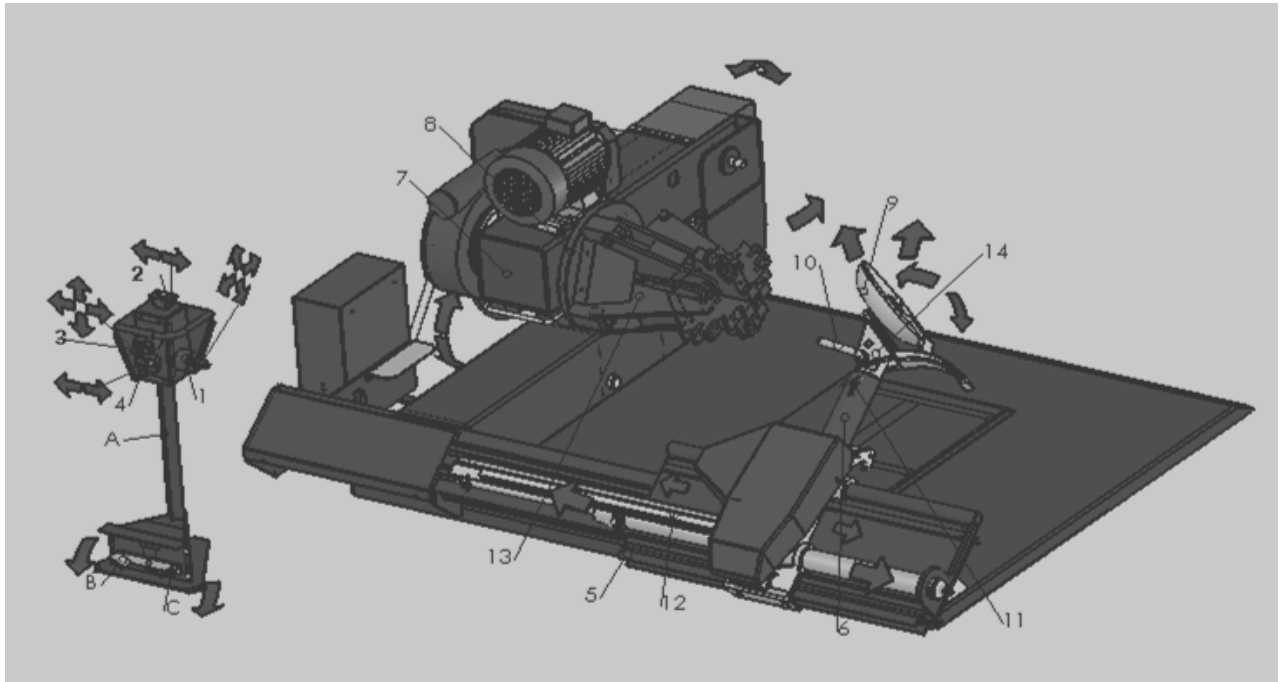

Fig22 Structure diagram B

Operation and machine structure instruction

Switch in reference to Fig 22

Manual switch control to control

1. the movement of mechanic arm and tool head control

2. movement of mechanical arm

3. movement of carriage and tool arm

4 open/ close of jaw

Pedal control:

B. chuck rotation pedal (clockwise)

C. chuck rotation pedal (counterclockwise)

5 carriage

6 mechanical arm

7 rotation arm

8 jaw

9 disk

10 tool head position joystick

11 mechanical arm position joystick

12 mechanical arm movement oil tank

13 tool arm

14 tool

15 power switch

16 rotation direction indicator

17 oil level indicator

18 hydraulic pressure adjust valve

19 hydraulic gauge

20 oil mark

LC590 is an universal tire changer applied to dismount/mount 14"-56" rim of truck, agricultural trailer , extractor and shovel loader. It has a mechanical arm (6) and a full automatic carriage (5) . The movement of the mechanical arm and the carriage are controlled by the console.

Installation and commission

Installation methods see Page7.

Compressor connect, see Fig 4 on P4.

Function check Fig22 Structure diagram B

1 Check if the movement of mechanical arm (6) and tool head (9) is correct. (See Fig 22 and Fig 23)

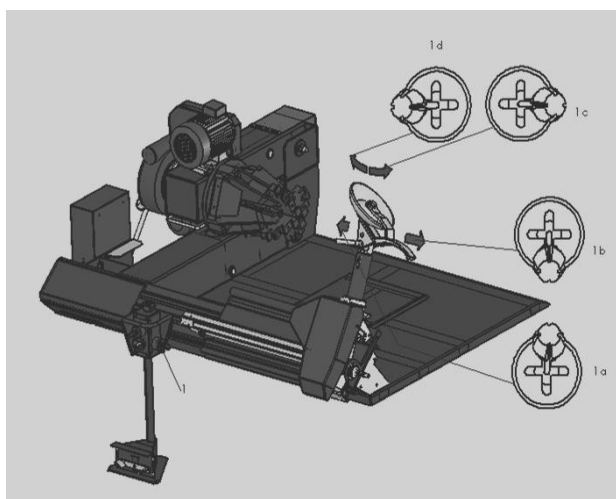

Fig23 structure diagram C

Push rightward switch 2 (Fig 22) , mechanical move rightward.

Push leftward switch 2 (Fig 22) , mechanical move leftward.

- 2 Check if the movement directions of the carriage (5) and tool arm (7) is correct (see Fig 22):
- Push leftward switch 3, carriage move leftward.
- Push rightward switch 3, carriage move rightward.
- Push upward the switch 3, the tool arm move upward
- Push downward the switch3, the tool arm move downward

3 Check if the function of the center chuck is

correct (see Fig 22):

- Push the switch4 leftward, the chuck will open.
- Push the switch4 rightward, the chuck will close.
- Step the pedal switch at the b side, the chuck will rotate clockwise.

Step the pedal switch at the c side, the chuck will rotate counter clockwise.



Fig 24 adjust throttle value

Adjust the throttle valve X >> the speed to rise up the tool arm Y will increase or decrease. (Fig24)



Fig25 adjust throttle value

Adjust the throttle valve W >> the speed to rotate the tool head Z will increase or decrease. (Fig25)

Tire clamp function:

Adjust the hydraulic clamp force of the chuck:

We can change the clamp force of the chuck by adjusting the pressure decrease valve rotation handle of the hydraulic power unit. The pressure ranges from 20 to 130 bar, which can be displayed via hydraulic gauge. When dismount/mount the light alloy rim or the rim of very thin, you should decrease the pressure. The standard work pressure is 130 bar.

Chuck with 4 jaws can clamp any rim of 14~56". To the rim of 42~56", we provide 4 extension rod can be mounted on the jaw (See Fig 12)

To the wheel of the diameter less than 800mm and exceed 1500mm, you should insert the pin into the second hole. (See the 11 in Fig22)

To the aluminum alloy rim, we can provide 4 nylon protective cover (see Fig 26).

The nylon protective cover should be mounted on the aluminum alloy rim (Fig26)

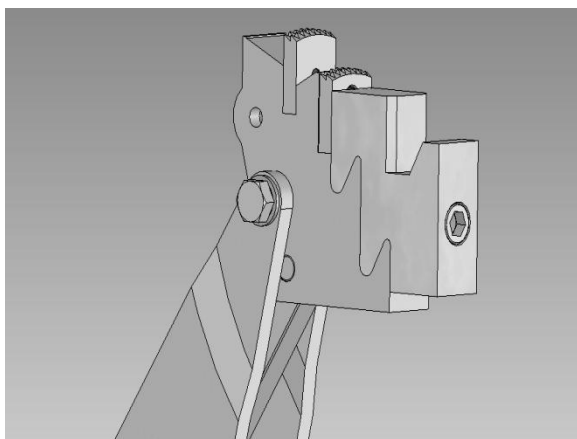

Fig26 mount nylon protective cover

Note: When mount/dismount the aluminum alloy rim difficult to handle, you can place 2 pins in the hole of the terminal of the rim to avoid the nylon protective cover sliding on the rim.

Dismount/mount wheel:

Passenger car wheel tubeless/ ring less

Completely deflate the wheel to be changed and place on the carriage. Pay attention to the construction of the rim. The small slope termination rim should be outside, that is far away from the chuck. Start the machine, use 4claws clamp the center hole or any other suitable

position. Rise up the tool arm to the suitable height. Move the carriage to the side far away from the chuck. Contact the press disk on the tool head against the termination of the tire. Continue rotating the wheel and move the carriage towards the tire to make the press disk be contacted with the tire and then continue pressing for a little distance. You can observe that there will be some clearance at the position of the tire and rim pressed by the press disk. Spread evenly a layer of Vaseline Oil in the clearance. Continue rotate and spread the oil until all the contact plane between the rim and tire is spread with oil. Move steeply rightward the carriage to make the press disk about 200mm from the termination of the tire. Rise up the mechanical arm and rotate the tool head and move the carriage to the other side of the tire and lower the mechanical arm and rotate the chuck and steeply move the carriage to make the press disk on the termination of the tire until the entire tire is detached from the rim.

Mount the tire

A Use the chuck to clamp the rim and fix the tire on the flange of the rim and keep it far away from the chuck.

B Place the tire on the carriage and move the carriage and rotation tool arm to insert the tire pliers into the side of the tire hole. Rotate the chuck to rise up the tire and use the press disk to press the right termination of the tire to move the tire leftwards to the proper position. At this moment, one flange of the tire has been mounted in the rim. Take off the tire pliers and continue pressing the tire leftwards until the right side of the tire into the right side of the rim and stop rotating the chuck and mount the tire pliers on the press disk. Rotate the chuck clockwise for a cycle to complete the mount of the tire and detach the tire pliers.

Engineer vehicle tire mount/dismount

A Place the wheel on the carriage and move the carriage.

B Clamp the chuck at the suitable position and rise up the tool arm and rotate the wheel counter clockwise. Use the press disk on the tool head to push and press the retaining ring and mount the 2

rim clamps as shown in Fig27.



Fig27

C Use the press disk on the tool head to continue press the tire making it close to the termination of the retaining ring. The tire rotates for 2cycles and then move the carriage leftwards. This process needs 15minutes for the bind of the tire and rim due to long time of compression each other. This process should be stopped until the right side of the tire is completely detached from the rim and detach the rim clamp.

D Use the crowbar to prized up one end of the ring and fix it with the press disk. Rotate the chuck to take off the ring and continue press the rum and take off the sealing ring. Rotate the chuck and use

the press key to pull the retaining ring and take off the rim and retaining ring.

E Move the carriage to the left side and use the press disk to press the termination of the tire. When you see the tire is detached from the rim, rotate the tool arm to place the tire on the tire carriage and move rightward the carriage to detach the tire from the rim.

F Mount the wheel in reference to the above procedure.

Warning! The movement of the especially heavy wheel, we need at least 2persons!

Troubleshooting and repair

Troubleshooting	reason	solution
Chuck does not rotate	<ol style="list-style-type: none">1 .Power plug not plugged into the socket2 .The wiring of the plug not correct3 .Power supply voltage not corresponding with the requirement.4 Main switch not connected5 Fuse blown.	<ol style="list-style-type: none">1 . Check if the power plug has been plugged into the socket effectively.2 . As per 2~3, see the solution 13 . Connect the main switch.4 . Change the fuse
The rotation force of the chuck not enough	<ol style="list-style-type: none">1. Choice of the voltage not correct2. Driven belt is loose3. Capacity of the fuse is small.	<ol style="list-style-type: none">1. Check if the power supply is corresponding with the ones on the name plate on the machine.2. Adjust the tension of the belt;3. Change fuse
Hydraulic jaw can not clamp the rim firmly	<ol style="list-style-type: none">1. Thermal-magnet switch not connect2. Work pressure of the hydraulic valve is adjusted too low.3. Hydraulic system pressure too low.	<ol style="list-style-type: none">1. Check if the rotation of the oil pump motor is correct2. Adjust the work pressure of the one way valve3. Settle the troubleshooting of the hydraulic system.
Hydraulic part of hydraulic system and machine can not work (carriage, tool arm and jaw)	<ol style="list-style-type: none">1. Rotation direction of the hydraulic oil pump motor is not correct.2. Thermal over-load protective device break3. 24V fuse broken	<ol style="list-style-type: none">1. Exchange fuse in the plug;2. Connect the thermal over load protector3. Change fuse

The other technical troubleshooting should be settled by the professional technicians authorized !

Maintenance

The operators should always clean and maintenance the machine.

The operators should maintenance the equipments in reference to the methods described in the instruction manual provided by the manufacturer.

Before clean and maintenance, you should cut off the power/pneumatic supply .

Mechanical maintenance

Periodically clean the chuck and carriage and lubricate carefully with gun.

Check the oil level of the hydraulic power unit. Add the wear resistance hydraulic oil with the viscosity required.

Transportation

The requirement to the rope or the methods to hoist, see the Fig15 of this manual.

Note:

Pull out the power plug and keep well the power cord if long time no use of machine.

Repair

No matter which troubleshooting, handle as per the methods listed on P12. The other troubleshooting should be handled by the professional personnel or contact with the dealer or the manufacturer..

Remind: After the troubleshooting happens and need repair, provide the following information

A model of machine; B series number; C detail of troubleshooting

Knowledge and note for the repair and maintenance

Before any maintenance and repair, you should cut off the power supply and air source to prevent the accident to the operator of equipment and the person responsible for the equipment should periodically check and survey.

- 1 . The power supply must be grounded reliable.
- 2 .The oil cup of the air regulator should be filled with the oil periodically and the oil feeding should be adjusted. When the pneumatic part active for 4times, one drop of oil will be feed.
- 3 、 You should secure the air supply pressure to be 8-10bar , or the machine can not operate normally.
- 4 、 Hydraulic power unit should use the wear-resistant hydraulic oil N46. You should not adopt the hydraulic oil of different chemical. Change the hydraulic oil one time for the total time to use the hydraulic oil reaches 600—800hours to prevent the abnormal operation of the hydraulic parts due to the deteriorate of oil.
- 5 、 Feed the lithium grease to secure the lubrication of the rotation parts periodically (at least once per 3months).
- 6 . Weekly check connect part to prevent loosing causing troubleshooting such as oil leakage.
7. Keep the hydraulic tank from moving to the limit position to prolong the life of the sealing parts inside.

8. For gearbox, change the grease(mix of lithium grease and motor oil)once half a year.

9.After each operation, timely cut off the power supply of electrical/air to prolong the life of the machine and save energy.

10、 At the end of one day or shift, you should clean the machine to prevent the rust of the surface of the machine causing the come off of the coat.

11、 Pay attention to the clean of each guide rail and spread the grease to keep the lubrication well.

Pneumatic	Hydraulic	Electrical
-----------	-----------	------------

(Fig28)		(Fig 29)	(Fig 30 and Fig31)	
01	solenoid valve	01 pump assembly	M1 pump motor	SF-2 main switch
02	solenoid valve	02 solenoid valve	M2 main shaft motor	Y1 solenoid valve coil
03	cylinder	03 solenoid valve	BK transformer	Y2 solenoid valve coil
04	cylinder	04 pressure valve	QF1 circuit brake	Y3 solenoid valve coil
05	cylinder	05 oil guide	QF2 circuit brake	Y4 solenoid valve coil
		06 hydraulic oil tank	K1 AC contactor	Q1 solenoid valve coil
		07 hydraulic oil tank	K2 AC contactor	Q2 solenoid valve coil
		08 hydraulic oil tank	SA-1 torsion switch	SS-1cross switch
		09 hydraulic oil tank	SA-2 torsion switch	SS-2cross switch
		10 hydraulic oil tank	SF-1 main switch	Q1 power supply switch

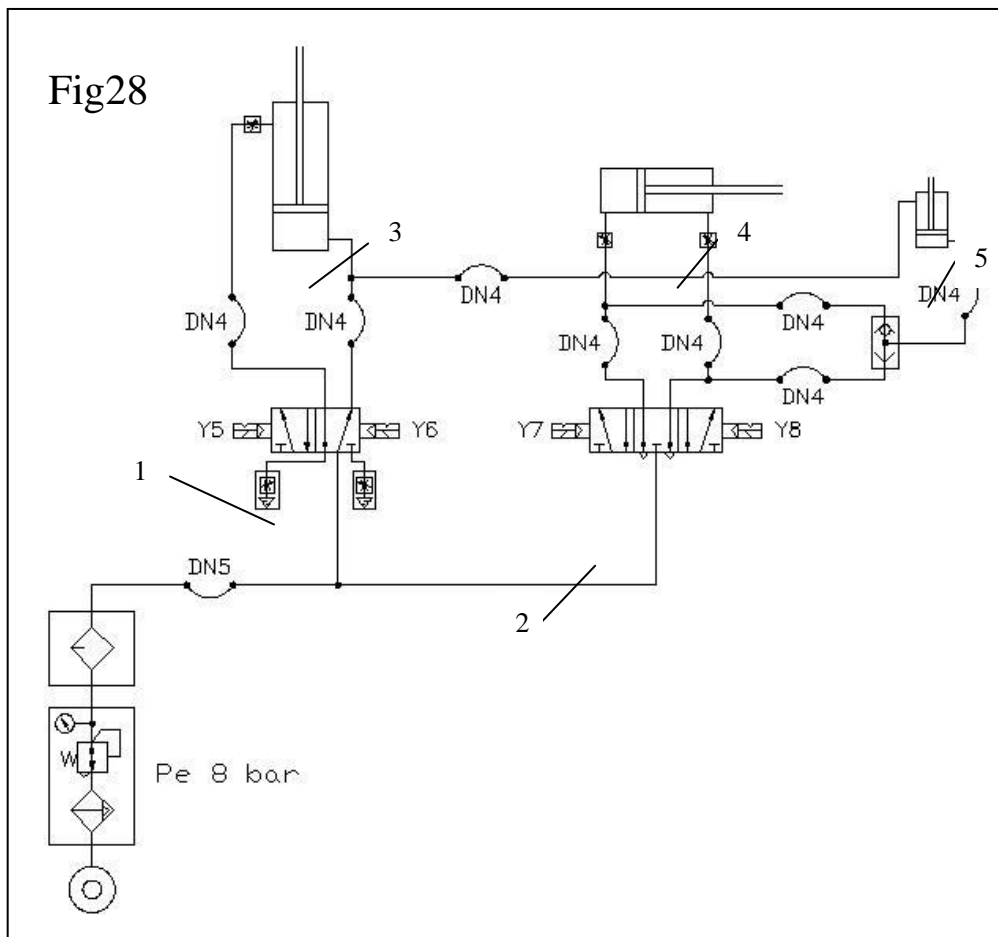
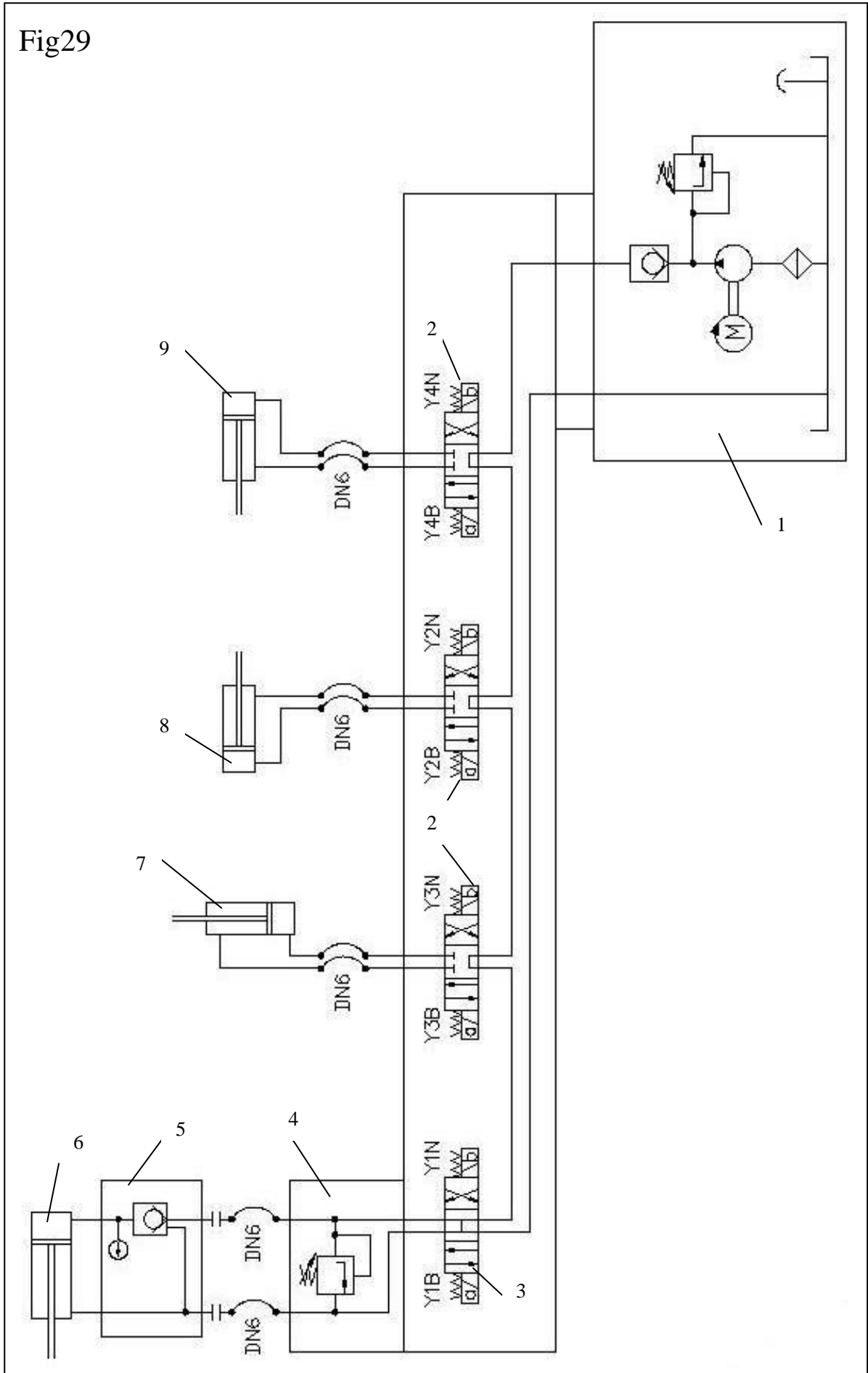

Fig29



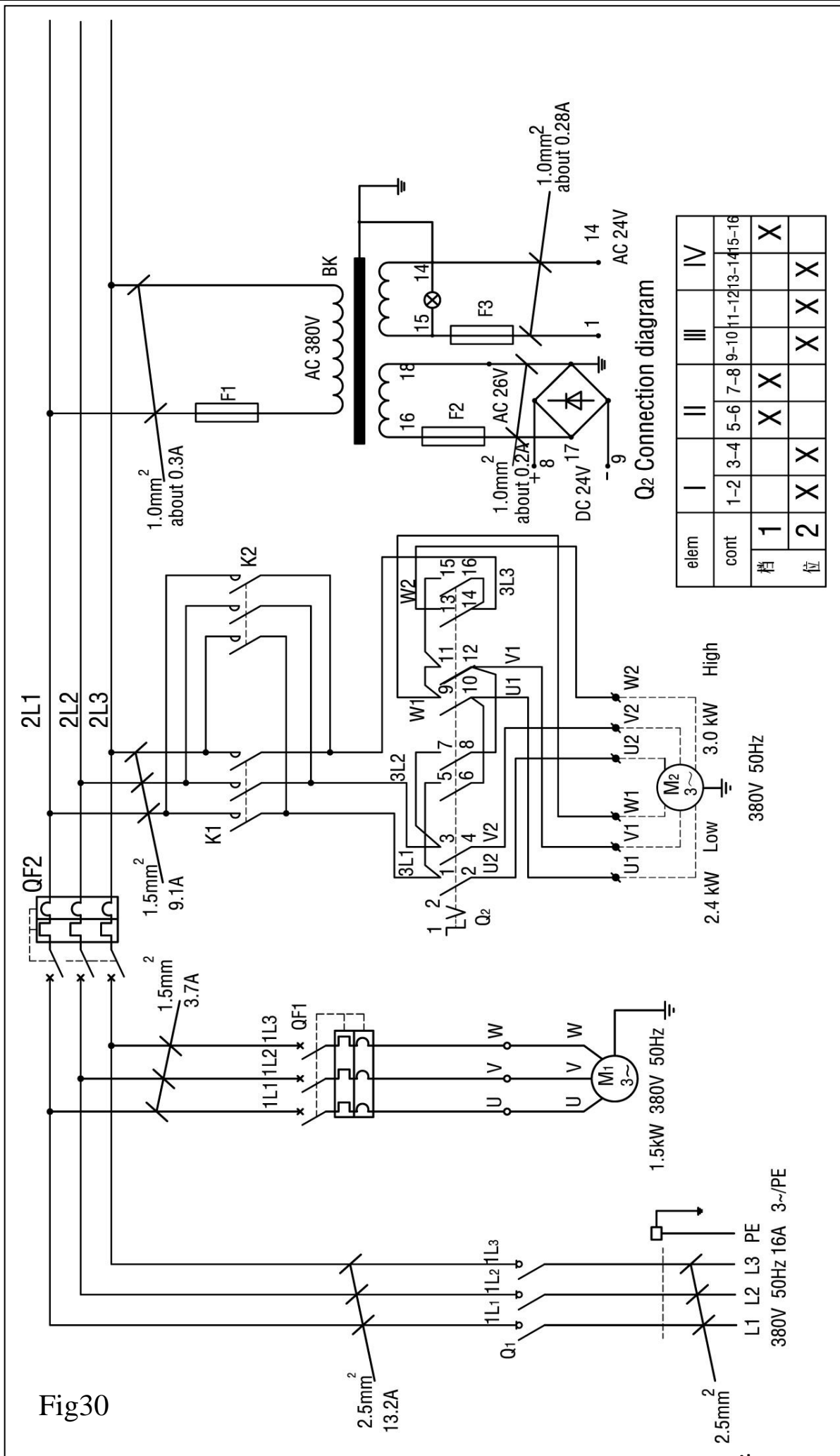

Fig30

Fig31

