

806-B

Organization:

To examine:

Approval:

Version: A-01

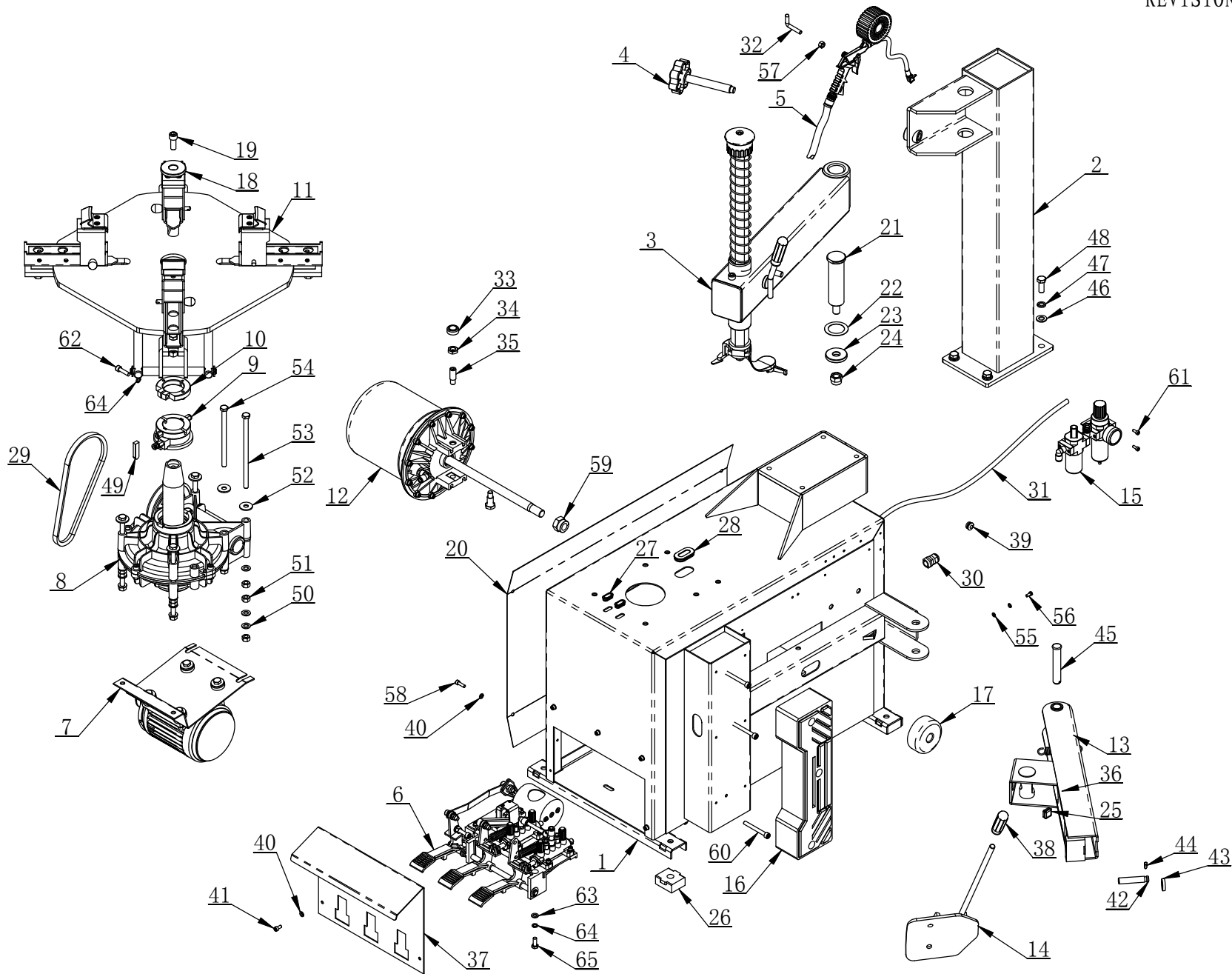

ITEM	PART. No	DESCRIPTION.	QT. Y
1	C-21-1100000	BODY	1
2	C-21-1200000	VERTICAL COLUMN	1
3	C-01-1300000	SWING ARM	1
4	C-54-1400000	HANDLE WHEEL	1
5	CT-P-1000000	INFLATING GUN ASSY	1
6	CT-D-1100000	PEDAL ASSEMBLY	1
7	CT-DJ-0334122	MOTOR	1
8	CT-J-3100000	GEARBOX ASSEMBLY	1
9	CT-Q-1000000	ROTATING UNION	1
10	CT-Q-6000000	CLAMP RING	1
11	CT-M-0100000	PNEVMATIC CHUCK	1
12	CT-LS-4100000	BEAD BREAKER CYLINDER ASSEMBLY	1
13	CT-B-5000000	BEAD BREAKING ARM ASSEMBLY	1
14	CT-C-4100000	BEAD BREAKER BLADE	1
15	CT-F-3111100	AIR REGULATOR ASSEMBIY	1
16	C-21-1000001	WASHER	1
17	C-21-1000002	RUBBER WASHER	1
18	C-54-1000012	PRESS COVER	1
19	GB70. 1-M12×30	INNER HEXA CYLINDRICAL SCREW	1
20	C-01-1000001	SIDE PANEL	1
21	C-01-1000002	ROCKER VERTICAL SHAFT	1
22	C-54-1000002	ADJUSTING WASHER	2
23	C-54-1000009	SHAFT WASHER	1
24	GB889. 1-M16	1-TYPE PREVAILING TORQUE TYPE HEXAGON LOCK NUT	1
25	C-54-1000015	STOP-UP	1
26	C-54-1000005	RUBBER FOOT	4
27	C-54-1000023	PLUG A	2
28	C-54-1000028	PLUG B	1
29	CT-DJ-0000007	英文名称	1
30	C-54-1000017	CABLE CONNECTOR	1
31	CT-E-UN00410	CABLE	1
32	C-71-1000024	INFLATING GUN HOOK	1
33	C-54-1000013	SEALED COVER	1
34	GB6172. 1-M14	HEXANGULAR THIN NUT	2
35	C-54-1000010	SCREWS M14X42	2
36	C-01-100000B	CIRCLIP	1
37	C-5B-1000002	PROTECTIVE COVER	1
38	TC-40-1200022	RUBBER COVER	1
39	C-71-1000027	HELPER RUBBE PLUG	1
40	GB95-6	FLAT WASHER	9

ITEM	PART. No	DESCRIPTION.	QT. Y
41	GB70. 1-M6×12	INNER HEXA CYLINDRICAL SCREW	5
42	C-7C-1000007	ROTATION SPINDLE	1
43	GB955-14	WAVE-FORM SPRING WASHER	1
44	GB85-M6×12	SQUARE HEAD CYLINDRICAL TERMINUS SET SCREW	1
45	GB882-18×100	PIN SHAFT	1
46	GB95-12	FLAT WASHER	4
47	GB93-12	STANDARD SPRING WASHER	4
48	GB5781-M12×30	HEXANGLUAR BOLT	4
49	GB1096-C12×8×45	COMMON FLAT KEY	1
50	GB95-10	FLAT WASHER	14
51	GB41-M10	HEXANGULAR NUT	14
52	GB96. 2-10	LARGE WASHER C GRADE	6
53	GB5781-M10X200	BOLT M10X200	4
54	GB5781-M10×160	HEXANGULAR BOLT	2
55	GB95-5	FLAT WASHER	2
56	GB5781-M5×12	HEXANGULAR BOLT	1
57	GB41-M8	HEXANGULAR NUT	1
58	GB70. 1-M6×20	INNER HEXA CYLINDRICAL SCREW	4
59	GB889. 1-M18X1. 5	PRRVAILING TORQUE M18X1. 5	1
60	GB70. 1-M8×70	INNER HEXA CYLINDRICAL SCREW	3
61	GB70. 1-M5×12	INNER HEXA CYLINDRICAL SCREW	2
62	GB70. 1-M8×30	INNER HEXA CYLINDRICAL SCREW	1
63	GB95-8	FLAT WASHER	2
64	GB93-8	STANDARD SPRING WASHER	3
65	GB5781-M8×20	HEXANGULAR BOLT	2

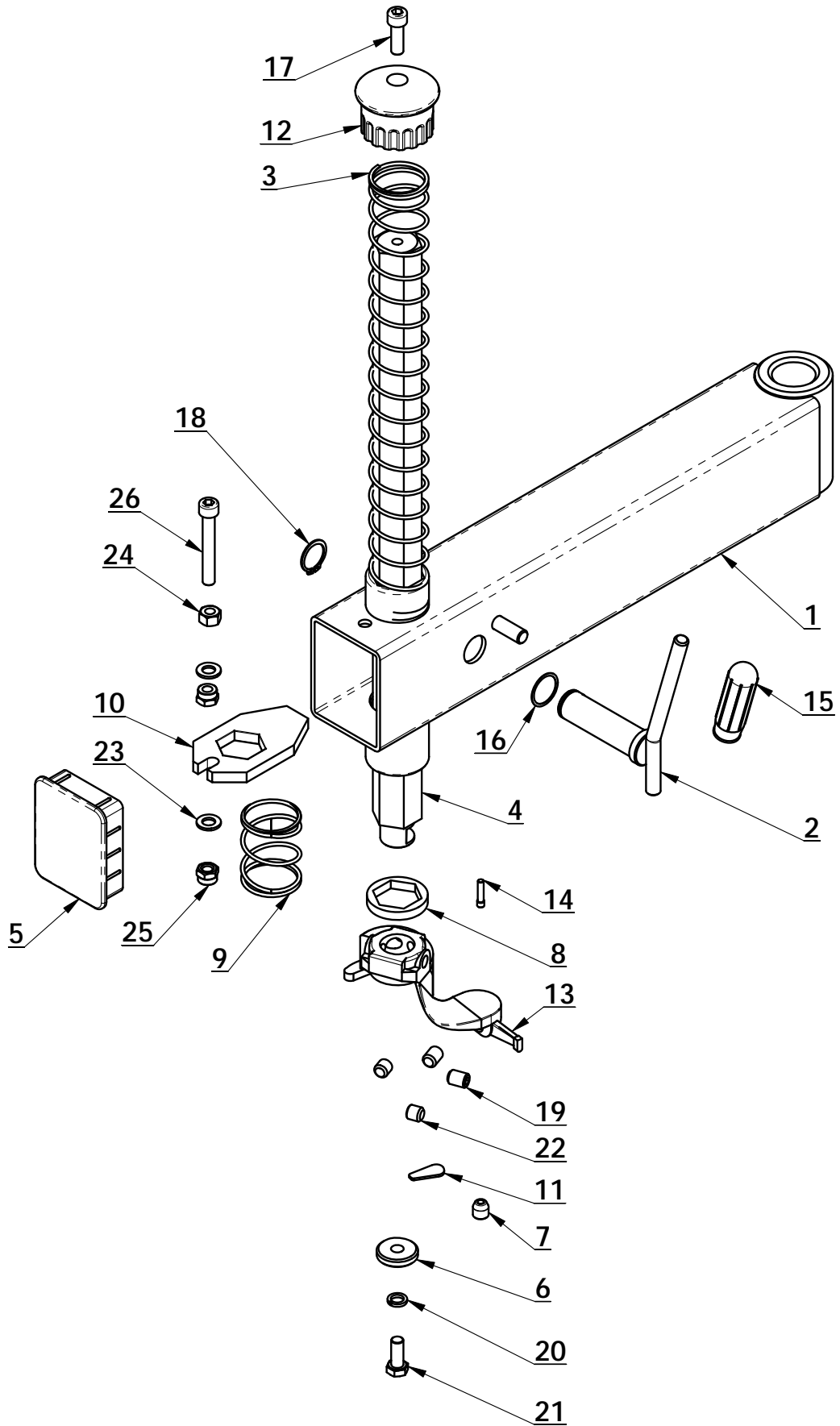

ITEM	PART. No	DESCRIPTION.	QT. Y
1	C-01-1310000	SWING ARM	1
2	C-54-1320000	LOCK HANDLE	1
3	C-01-1300001	VERTICAL SHAFT SPRING	1
4	C-01-1300002	HEXAGON SHAFT	1
5	C-01-1300003	DECORATING COVER	1
6	C-54-1300008	PRESS WASHER	1
7	C-54-1300009	ROLLER	1
8	C-54-1300007	SHOCK ABSORBER WASHER	1
9	C-01-1300004	SPRING	1
10	C-01-1300005	HEXAGON LOCK PLATE	1
11	C-54-8000007	PLASTIC COVER	1
12	C-71-1300006	VERTICAL SHAFT COVER	1
13	C-54-1300004	DEMOUNTING HEAD	1
14	C-54-1300006	ROLLER BOLT	1
15	TC-40-1200022	RUBBER COVER	1
16	C-54-1300013	ADJUSTING WASHER	1
17	GB70. 1-M10×30	INNER HEXA CYLINDRICAL SCREW	1
18	GB894. 1-25	SHAFT ELATIC BIG RETAINING RING A-TYPE	1
19	GB77-M12×16	INNER HEXA FLAT TERMINUS SET SCREW	2
20	GB93-10	STANDARD SPRING WASHER	1
21	GB5783-M10×25	HEXANGULAR BOLT	1
22	GB77-M12×12	INNER HEXA FLAT TERMINUS SET SCREW	2
23	GB95-10	FLAT WASHER	2
24	GB41-M10	HEXANGULAR NUT	1
25	GB889. 1-M10	1-TYPE PREVAILING TORQUE TYPE HEXAGON LOCK NUT	2
26	GB70. 1-M10×70	INNER HEXA CYLINDRICAL SCREW	1

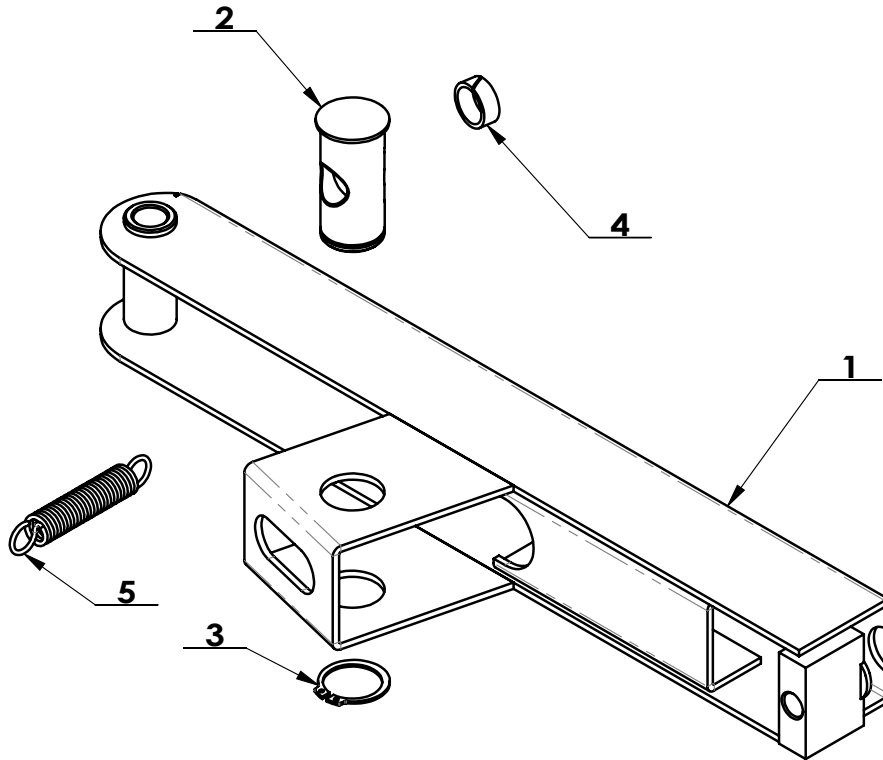

ITEM	PART. No	DESCRIPTION.	QT. Y
1	CT-B-5100000	BEAD BREAKING ARM ASSEMBLY	1
2	CT-B-4000001	BEAD BREAKING ARM SLIDE BUSHING	1
3	GB894. 1-34	SHAFT ELATIC BIG RETAINING RING A-TYPE	1
4	CT-B-2000001	SLIDE SPACER	1
5	CT-B-4000003	SPRING	1

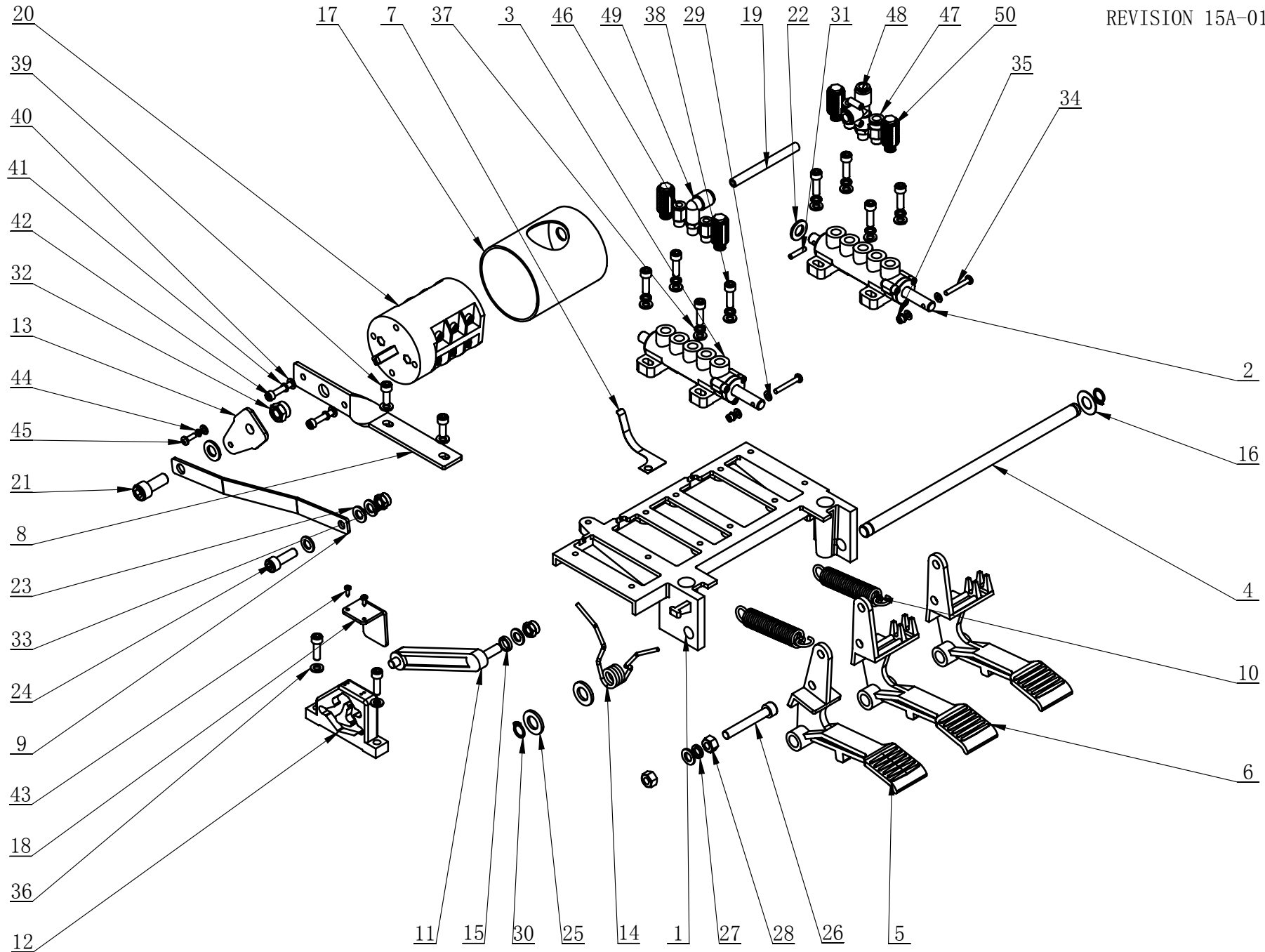

ITEM	PART. No	DESCRIPTION.	QT. Y
1	CT-D-1100003	PEDAL SUPPORT	1
2	CT-D-1110000	VALVE	1
3	CT-D-1120000	VALVE	1
4	CT-D-1100004	BOTTOM SHAFT	1
5	CT-D-1100001	PEDAL	1
6	CT-D-1100002	PEDAL	2
7	CT-D-1100013	SPRING PLATE	1
8	CT-D-1100005	SWITCH BASE PLATE	1
9	CT-D-1100006	SWITCH CONNECTING PLATE	1
10	CT-D-1100007	SPRING	2
11	CT-D-1100008	CAM CONNECTING ROD	1
12	CT-D-1100009	CAM	1
13	CT-D-1100010	REVERSE LEVER	1
14	CT-D-1100012	TORSION SPRING	1
15	CT-D-1100016	SPACER	1
16	CT-D-1100015	WASHER	1
17	CT-D-1100014	SWITCH COVER	1
18	CT-D-1100011	CAM BAFFLE PLATE	1
19	CT-D-1100017	HOSE	1
20	CT-D-1100018	SWITCH	1
21	GB70. 1-M10×25	INNER HEXA CYLINDRICAL SCREW	1
22	GB95-10	FLAT WASHER	2
23	GB95-8	FLAT WASHER	5
24	GB70. 1-M8×25	INNER HEXA CYLINDRICAL SCREW	1
25	GB95-12	FLAT WASHER	2
26	GB70. 1-M8×55	INNER HEXA CYLINDRICAL SCREW	1
27	GB93-8	STANDARD SPRING WASHER	1
28	GB41-M8	HEXANGULAR NUT	2
29	GB95-4	FLAT WASHER	5
30	GB894. 1-12	SHAFT ELATIC BIG RETAINING RING A-TYPE	2
31	GB879. 1-4×20	ELASTIC CYLINDRICAL PIN, HEAVY	1
32	GB889. 1-M10	1-TYPE PREVAILING TORQUE TYPE HEXAGON LOCK NUT	1
33	GB889. 1-M8	1-TYPE PREVAILING TORQUE TYPE HEXAGON LOCK NUT	2
34	GB818-M4×30-H	CROSS PANHEAD SCREW	2
35	GB889. 1-M4	1-TYPE PREVAILING TORQUE TYPE HEXAGON LOCK NUT	2
36	GB95-6	FLAT WASHER	12
37	GB93-6	STANDARD SPRING WASHER	8
38	GB70. 1-M6×20	INNER HEXA CYLINDRICAL SCREW	10
39	GB70. 1-M6×16	INNER HEXA CYLINDRICAL SCREW	2
40	GB95-5	FLAT WASHER	2

ITEM	PART. No	DESCRIPTION.	QT. Y
41	GB93-5	STANDARD SPRING WASHER	2
42	GB70. 1-M5×25	INNER HEXA CYLINDRICAL SCREW	2
43	GB845-ST2. 9×9. 5 H C	CROSS PANHEAD TAPPING SCREW	2
44	GB93-4	STANDARD SPRING WASHER	1
45	GB818-M4×12-H	CROSS PANHEAD SCREW	1
46	FPC 6-01	MALE STRAIGHT	2
47	FPC 8-01	MALE STRAIGHT	2
48	FPD 8-01	MALE RUN TEE	1
49	FPL 8-01	INSERT ELBOW Φ 8, R1/8	1
50	FSK 01	PLASTIC PARTICLE SILENCER	4

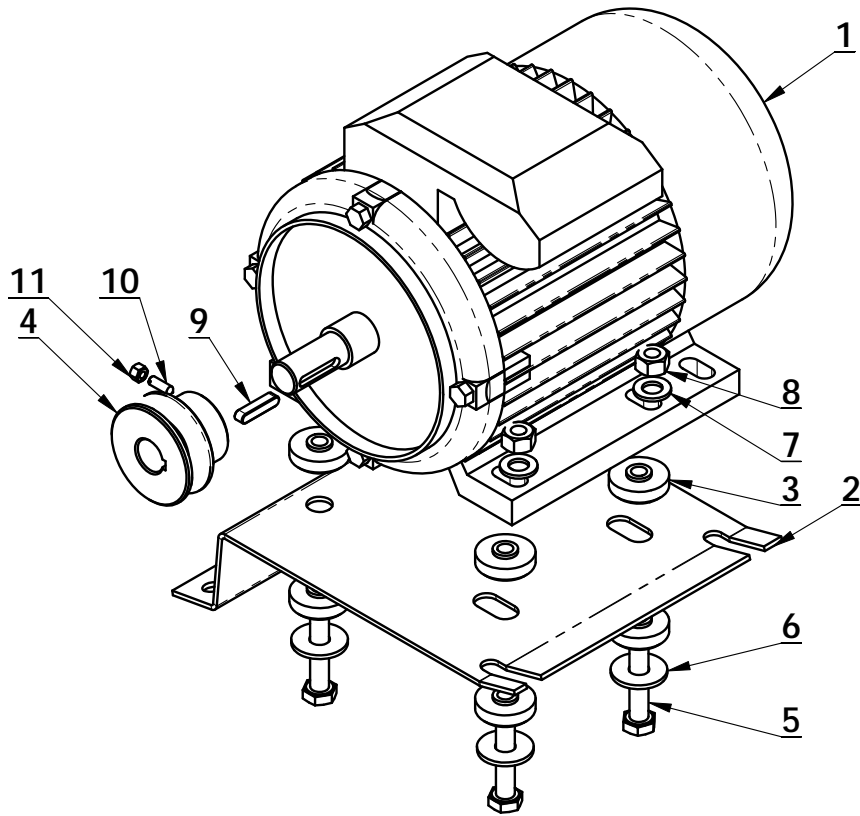

ITEM	PART. No	DESCRIPTION.	QT. Y
1	CT-DJ-0018112	MOTOR	1
2	CT-DJ-0000001	MOTOR SUPPORT	1
3	CT-DJ-0000002	RUBBER WASHER	8
4	CT-DJ-0000003	MOTOR BELT PULLEY	1
5	GB5781-M10×50	HEXANGULAR BOLT	4
6	GB96. 2-10	LARGE WASHER C GRADE	4
7	GB95-10	FLAT WASHER	4
8	GB41-M10	HEXANGULAR NUT	4
9	GB1096-6×6×28	COMMON FLAT KEY	1
10	GB71-M5×16	SLOTTED CONIC HEAD SET SCREW	1
11	GB41-M5	HEXANGULAR NUT	1

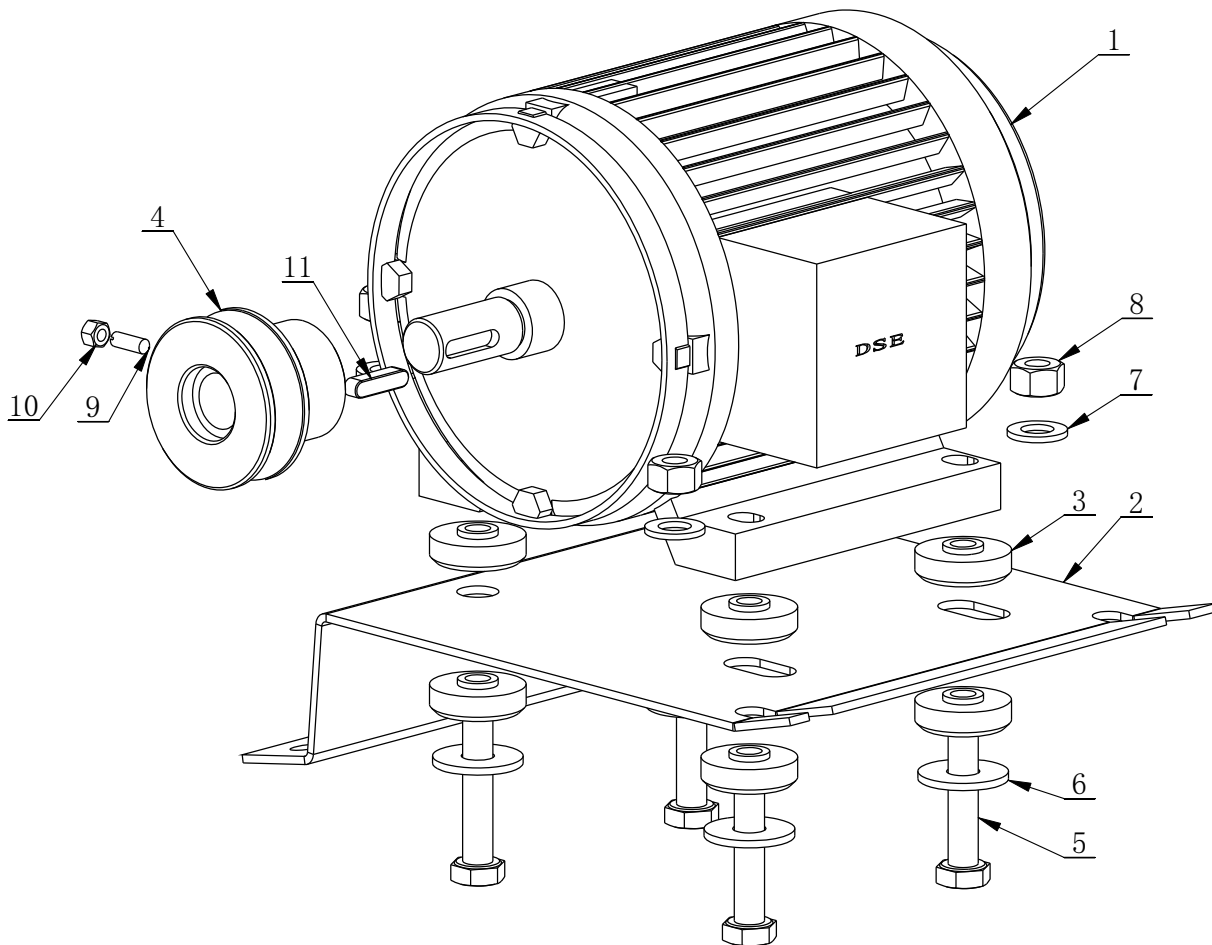

ITEM	PART. No	DESCRIPTION.	QT. Y
1	CT-DJ-0034122	MOTOR (0.75KW 380V 50Hz 3P)	1
2	CT-DJ-0000001	MOTOR SUPPORT	1
3	CT-DJ-0000002	RUBBER WASHER 220V MOTOR BELT PULLEY (Φ 58X40)	8
4	CT-DJ-0000003		1
5	GB5781-M10 \times 50	HEXANGULAR BOLT	4
6	GB96.2-10	LARGE WASHER C GRADE	4
7	GB95-10	FLAT WASHER	4
8	GB41-M10	HEXANGULAR NUT	4
9	GB71-M5 \times 16	SLOTTED CONIC HEAD SET SCREW	1
10	GB41-M5	HEXANGULAR NUT	1
11	GB1096-6 \times 6 \times 25	COMMON FLAT KEY	1

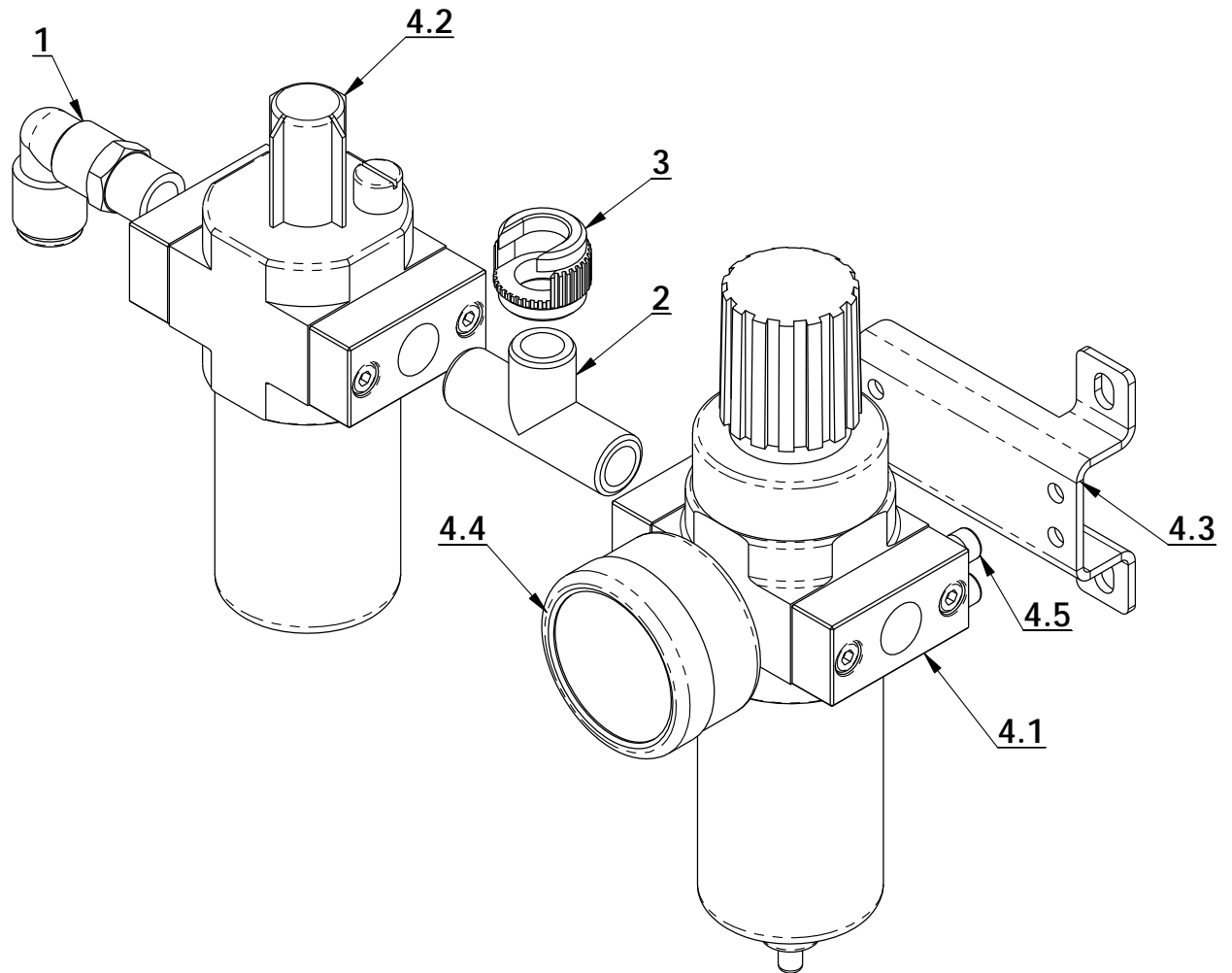

ITEM	PART. No	DESCRIPTION.	QT. Y
1	FPL 8-02	INSERT ELBOW $\Phi 8$, R1/4	1
2	PEH 02-02	FAMALE UNION TEE	1
3	C-01-1500004	OPEN NUT	1
4	CT-F-3000100	AIR REGULATOR	1
4.1	CT-F-3000010	OIL CPU	1
4.2	CT-F-3000020	WATER CPU	1
4.3	CT-F-2000009	AIR REGULATOR BRACKET	1
4.4	CT-F-2000003	PRESSURE GAUGE	1
4.5	GB70.1-M4 \times 8	INNER HEXA CYLINDRICAL SCREW	4

CT-LS-4100000

REVISION 15A-01

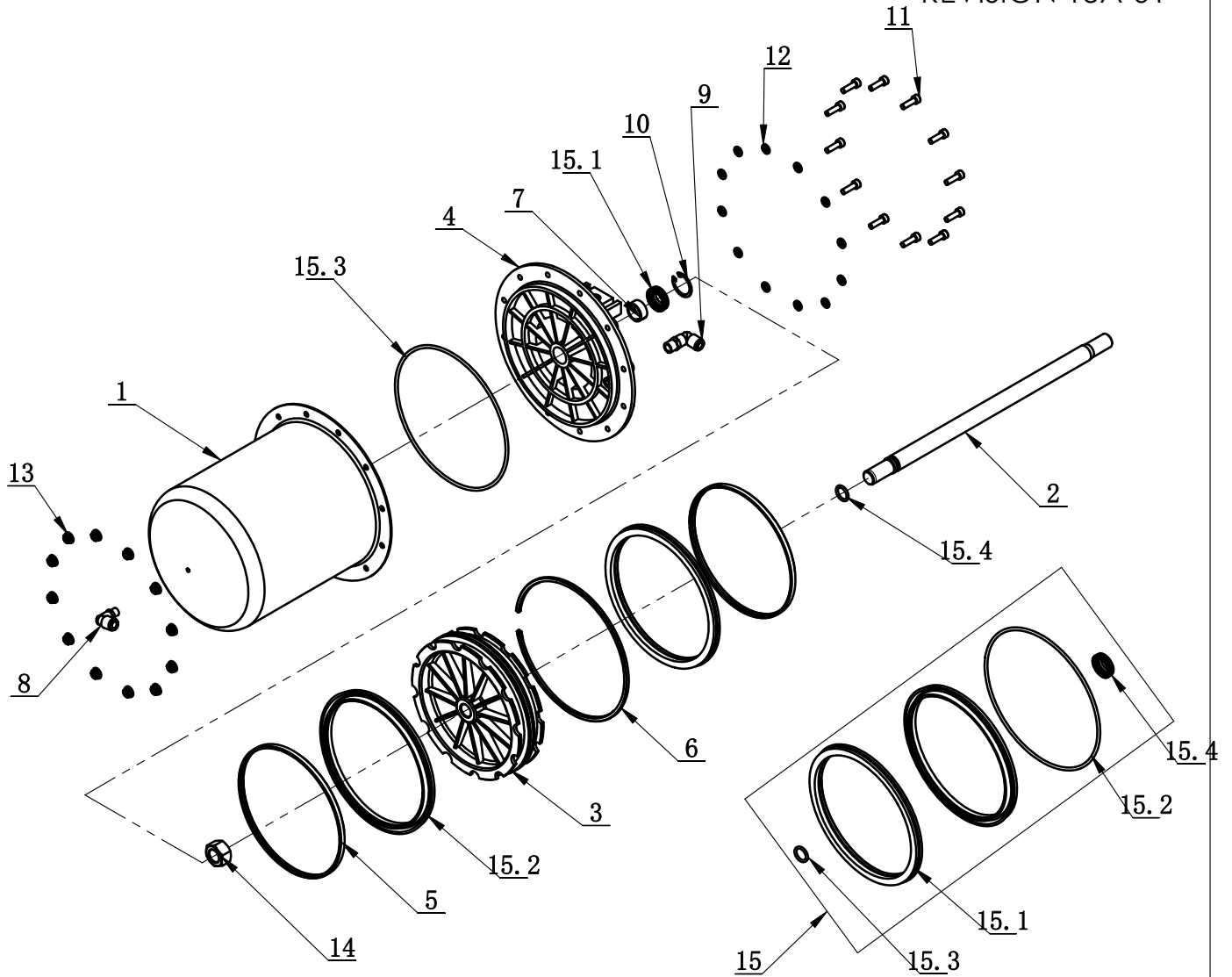

ITEM	PART. No	DESCRIPTION.	QT. Y
1	CT-LS-1100002	CYLINDER BODY	1
2	CT-LS-4100001	CYLINDER PISTON ROD	1
3	CT-LS-1100003	PISTON	1
4	CT-LS-1100004	CYLINDER COVER	1
5	CT-LS-1100006	CLAMP RING	2
6	CT-LS-1100007	PISTON SUPPORT RING	1
7	CT-LS-1100008	GUIDER SPACER	1
8	FPL 8-01	INSERT ELBOW $\Phi 8$, R1/8	1
9	FPL 8-02	INSERT ELBOW $\Phi 8$, R1/4	1
10	GB893. 2-30	ELASTIC RETAINING RING B-TYPE	1
11	GB70. 1-M6 \times 20	INNER HEXA CYLINDRICAL SCREW	12
12	GB95-6	FLAT WASHER	12
13	GB6177. 1-M6	HEXA FLANGE NUT	12
14	GB6171- M18 \times 1. 5	NUT THIN TOOTH	1
15	CT-LS-1110000	CYLINDER SEALING PARTS ASSEMBLY	1
15. 1	CT-LS-1100009	Y-RING	2
15. 2	GB3452. 1-185 \times 3. 55-G	O-RING G TYPE	1
15. 3	GB3452. 1-15. 5 \times 2. 65-G	HYDRAULIC-PNEUMATIC RUBBER O-RING G TYPE	1
15. 4	CT-Y-0160007	SEAL-ROD, CYLNDR	1

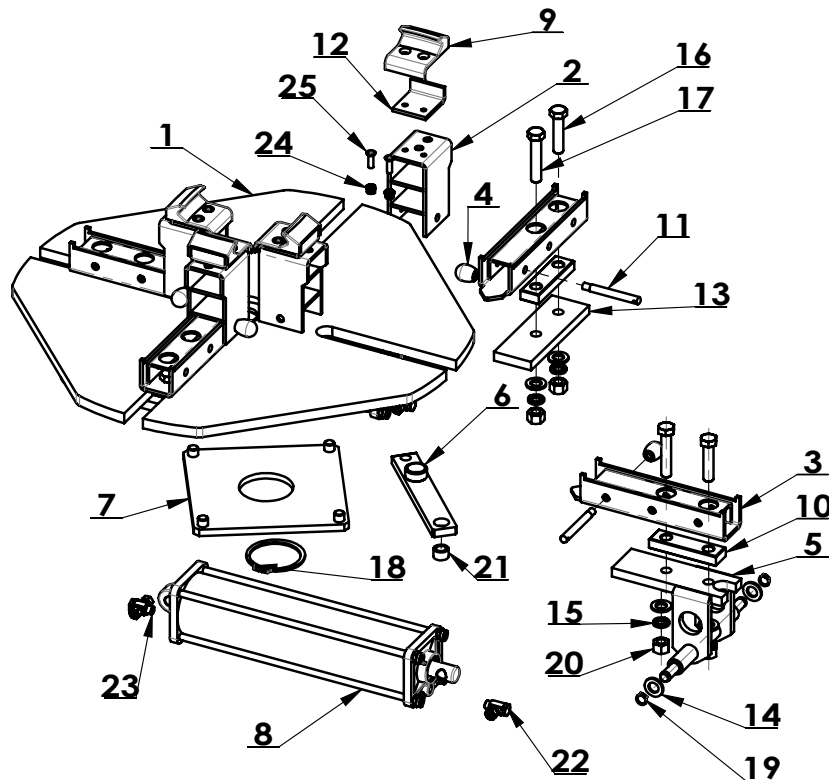

ITEM	PART. No	DESCRIPTION.	QT. Y
1	CT-M-0110000	TURNTABLE	1
2	CT-M-0120000	BRACKET	4
3	CT-M-0130000	SLIDER	4
4	JB / T7271. 4-94-M8-B	HAND SHANK B-type	4
5	CT-Y-0130000	CYLINDER BRACKET	2
6	CT-Y-0140000	CONNECTION PLATE	4
7	CT-Y-0150000	SQUARE TURNTABLE	1
8	CT-Y-0160000	CYLINDER ASSEMBLY	2
9	CT-M-0100001	CLAW	4
10	CT-M-0100002	SLIDER	4
11	CT-M-0100003	PIN SHAFT	4
12	CT-M-0100004	PLATE WITH	4
13	CT-Y-0100004	PRESS PLATE	2
14	GB95-12	FLAT WASHER	12
15	GB93-12	STANDARD SPRING WASHER	8
16	GB5782-M12×50	HEXANGULAR BOLT	4
17	GB5782-M12×60	HEXANGULAR BOLT	4
18	GB894. 1-65	SHAFT ELATIC BIG RETAINING RING A-TYPE	1
19	GB894. 1-12	SHAFT ELATIC BIG RETAINING RING A-TYPE	4
20	GB41-M12	HEXANGULAR NUT	8
21	CT-Y-0100003	SPACER	4
22	CT-Y-0100007	HINGE ELBOW $\Phi 6$ R1/8"	2
23	CT-Y-0100009	HINGE ELBOW $\Phi 6$	2
24	GB889. 1-M6	1-TYPE PREVAILING TORQUE TYPE HEXAGON LOCK NUT	8
25	GB819. 1-M6×20-H	CROSS COUNTERSUNK SCREW STEEL 4.8 GRADE	8

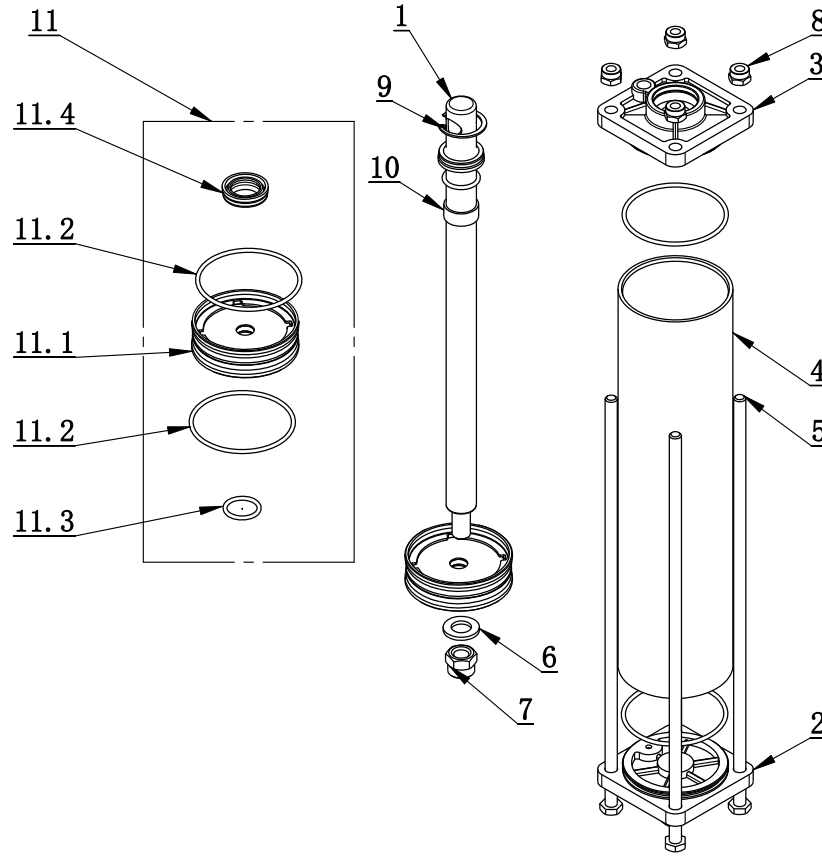

ITEM	PART. No	DESCRIPTION.	QT. Y
1	CT-Y-0160001	SHAFT-CYLNR	1
2	CT-Y-0160003	REAR COVER	1
3	CT-Y-0160002	FRONT COVER	1
4	CT-Y-0160006	SLEEVE-CYLNR 70	1
5	CT-Y-0160004	BOLT	4
6	GB95-12	FLAT WASHER	1
7	GB889. 1-M12	1-TYPE PREVAILING TORQUE TYPE HEXAGON LOCK NUT	1
8	GB889. 1-M8	1-TYPE PREVAILING TORQUE TYPE HEXAGON LOCK NUT	4
9	GB893. 1-30	ELASTIC RETAINING RING A-TYPE	1
10	JH1 2010	BEARING-SLIDE	1
11	CT-Y-1121000	CYLINDER SEALING PARTS ASSEMBLY	1
11.1	CT-Y-0161000	PISTON-W/WSHR, ASSY	1
11.2	GB3452. 1-65×2. 65	HYDRAULIC-PNEUMATIC RUBBER O-RING G TYPE	2
11.3	GB3452. 1-20×2. 65	HYDRAULIC-PNEUMATIC RUBBER O-RING G TYPE	1
11.4	CT-Y-0160007	SEAL-ROD, CYLNR	1

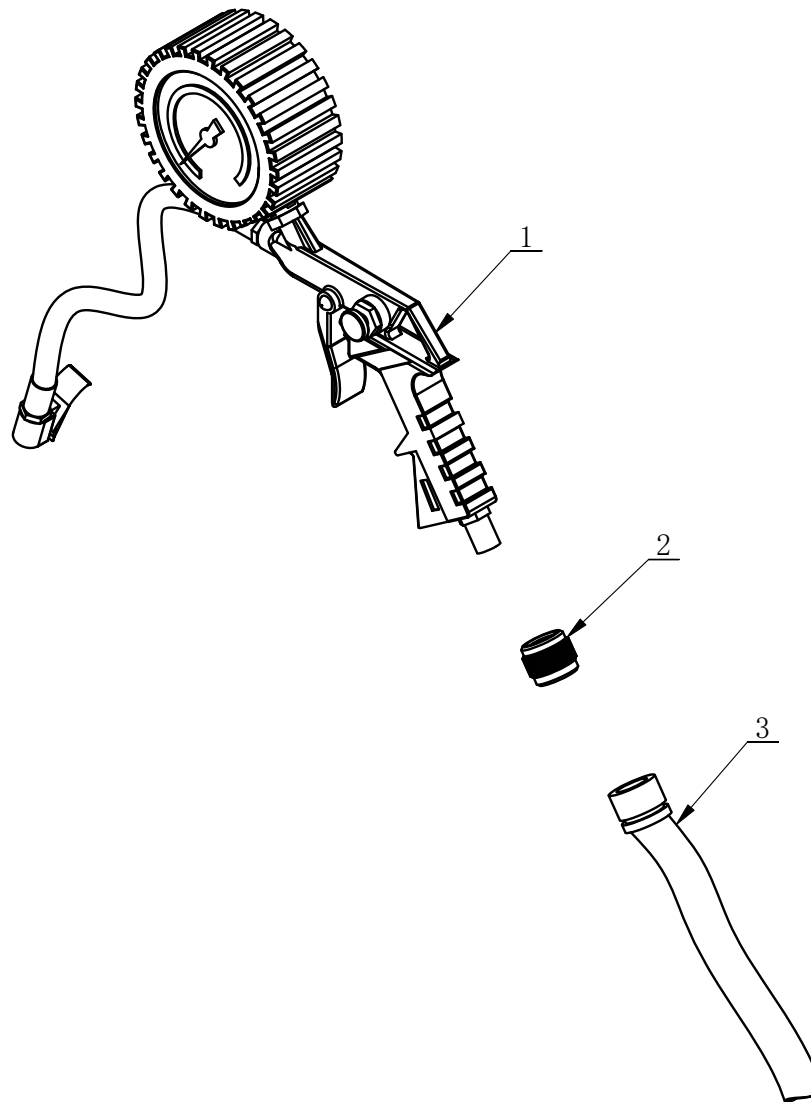

ITEM	PART. No	DESCRIPTION.	QT. Y
1	CT-P-1000001	INFLATING GUN	1
2	C-01-1500004	OPEN NUT	1
3	CT-P-1000002	INFLATION HOSE	1

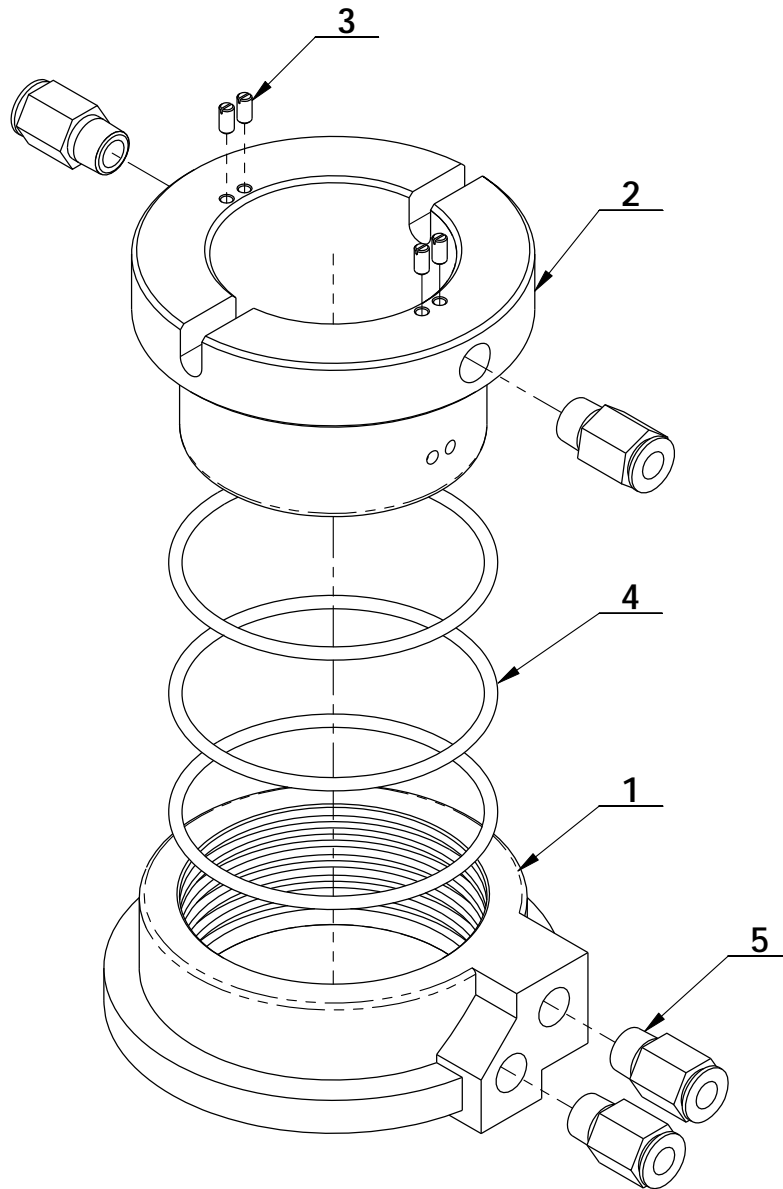

ITEM	PART. No	DESCRIPTION.	QT. Y
1	CT-Q-1000001	AIR GUIDE EXTERNAL BUSHING	1
2	CT-Q-1000002	AIR GUIDE ROTATION BUSHING	1
3	GB73-M3×6	SLOTTED FLATTEN HEAD SET SCREW	4
4	GB3452. 1-60×2. 65-G	HYDRAULIC-PNEUMATIC RUBBER O-RING G TYPE	3
5	FPC 6-01	MALE STRAIGHT	4

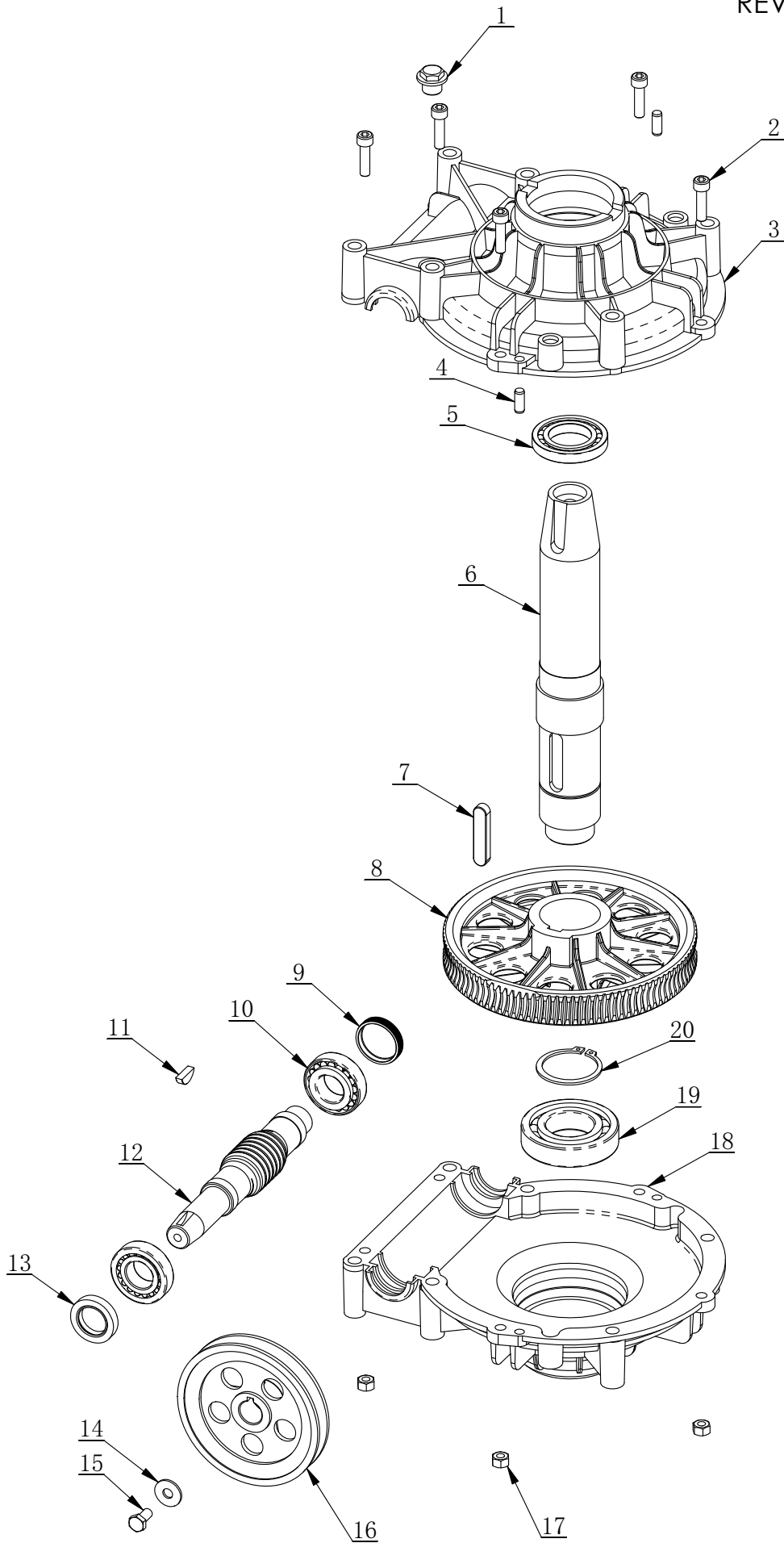

ITEM	PART NO.	DESCRIPTION	QTY
1	TC-10-1400013	BOLT	1
2	GB70. 1-M8×30	INNER HEXA CYLINDRICAL SCREW	5
3	CT-J-0000006	GEARBOX TOP	1
4	GB119. 1-8×20	CYLINDRICAL PIN	2
5	GB276-6010	DEEP GROOVE BALL BEARINGS	1
6	CT-J-0000001	WORM SHAFT	1
7	GB1096-12×8×56	COMMON FLAT KEY	1
8	CT-J-0000003	WORM	1
9	CT-J-0100000	CAP	1
10	GB297-30205	CYLINDRICAL BALL BEARING	2
11	GB1099. 1-6×9×22	COMMON SEMI-CIRCULAR KEY	1
12	CT-J-0000004	WORM ROD	1
13	FB25-40 GB13871. 92	SEALED RING	1
14	GB96. 2-8	LARGE WASHER C GRADE	1
15	GB5781-M8×16	HEXANGULAR BOLT	1
16	CT-J-0000008	BELT PULLEY	1
17	GB41-M8	HEXANGULAR NUT	5
18	CT-J-0000005	GEARBOX TOP	1
19	GB276-6208	DEEP GROOVE BALL BEARINGS	1
20	GB894. 1-50	SHAFT ELATIC BIG RETAINING RING A-TYPE	1

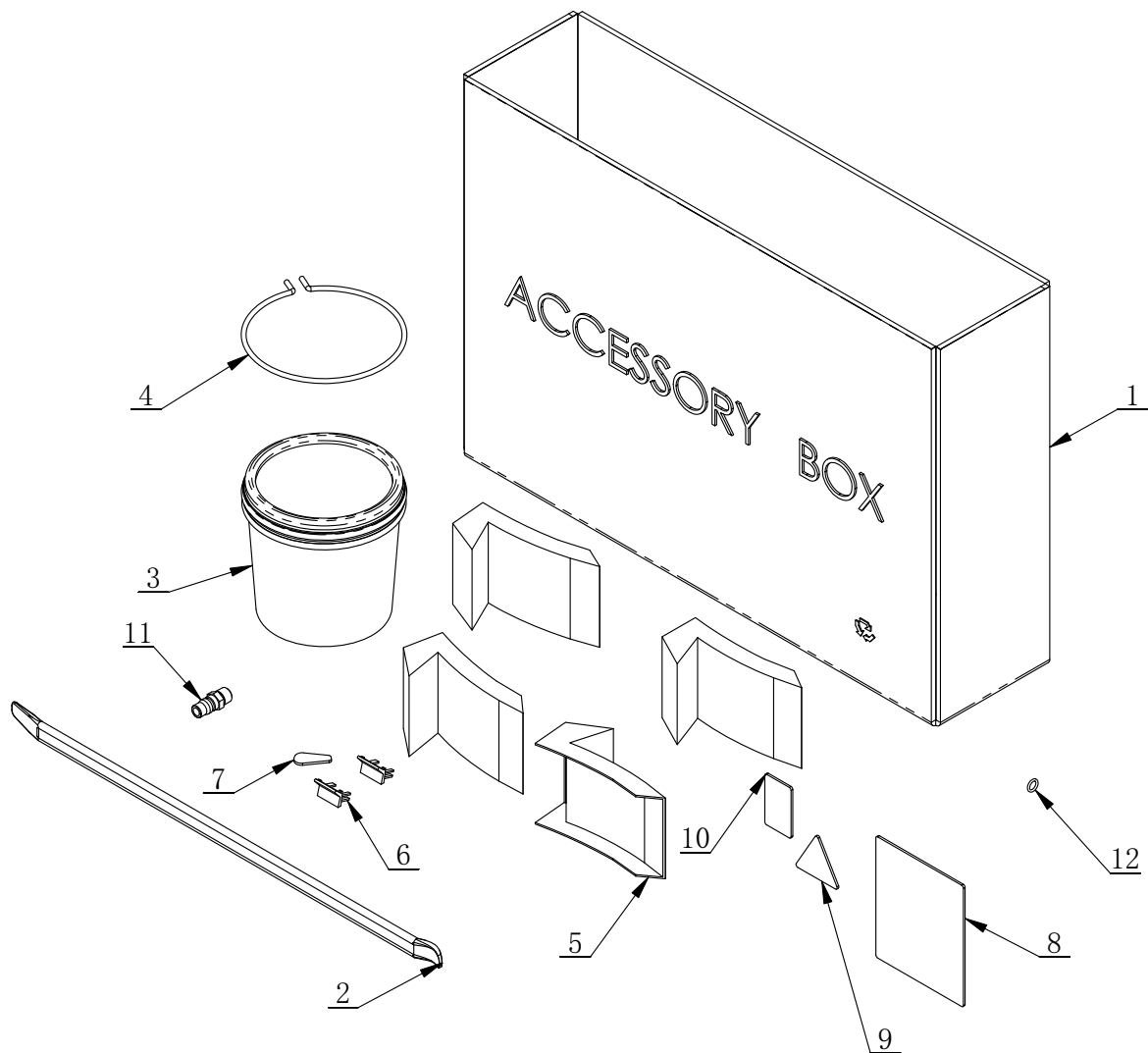

ITEM	PART. No	DESCRIPTION.	QT. Y
1	C-54-8000002	ACCESSORY BOX	1
2	C-54-8000003	20INCH CROWBAR	1
3	C-54-8100000	GREASE CONTAINER	1
4	C-54-8000004	BRACKET	1
5	C-54-8000005	CLAMP PROTECTION COVER	4
6	C-54-8000006	SHEATH	2
7	C-54-8000007	PLASTIC COVER	1
8	C-54-8000008	USER MANUAL	1
9	C-54-8000009	PASS CARD	1
10	C-54-8000010	GUARANTEE	1
11	C-54-8000011	AIR SUPPLY CONNECTOR	1
12	GB / T 3452.1-2005 8x2.65	HYDRAULIC-PNEUMATIC RUBBER O-RING G TYPE	1