

WHEEL BALANCER USER MANUAL

1. PREFACE	1
2. INSTALLATION AND OPERATION	4
3. TECHNICAL PARAMETER	5
4. TRANSPORTATION AND INSTALLATION	5
5. SAFETY AND PRECAUTIONS	6
6. CONFIGURATIONS	7
7. INSTALLATION	7
8. DISPLAY PANEL AND BUTTONS	8
9. BALANCE OPERATION	8
10. HIDDEN WEIGHT (WEIGHT SPLIT) FUNCTION	11
11. OPT FUNCTION	12
12. CALIBRATIONS	13
13.MENU INTRODUCTION	14
14. ERROR LIST	17
15. MAINTENACE	17

1. PREFACE

WARNING

There will be one year of warranty period on the condition that the machine including the operation system, tools and accessories are used properly and/or without damage. During this period, the manufacturer will repair or replace the parts returned or the machine itself, sustaining the costs but not accepting responsibility for normal wear and tear, incorrect use or transportation, or failure to carry out maintenance. The manufacturer will not inform the customer about any improvements to the products or the upgrading of the production line.

INTRODUCTION

The purpose of this manual is to provide the owner and operator of this machine with a set of safe and practical instructions for the use and maintenance of the wheel balancer.

If such instructions are carefully followed, the machine will offer you the levels of efficiency and duration.

The following paragraphs define the levels of danger regarding the machine.



DANGER: Refers to immediate danger with the risk of serious injury or death.



WARNING: Dangers or unsafe procedures that can cause serious injury or death.



ATTENTION: Dangers or unsafe procedures that can

cause minor injuries or damage to property.

Read these instructions carefully before using the machine. Keep this manual and the illustrated materials supplied with the equipment in a folder near the place of operation so as to allow the machine operators to consult the documentation at any time.

The manual is only to be considered valid for the machine serial number and model stated on the attached nameplate.

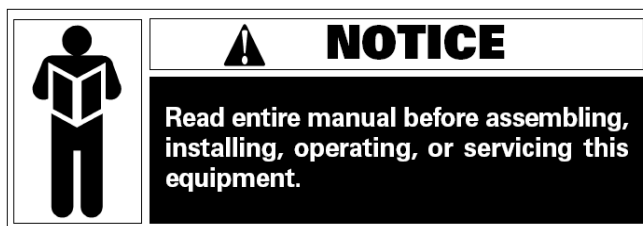

The instructions and information described in this manual must always be complied with: the operator will be held responsible for any operation not specially described and authorized in this manual.

Some of the illustrations contained in this booklet have been taken from pictures of prototypes: standard production machines may differ slightly in certain respects. These instructions are for the attention of personnel with basic mechanical skills. We have therefore condensed the descriptions of each operation by omitting detailed instructions, for example, how to loosen or tighten the fixing devices. Do not attempt to perform operations unless properly qualified or with suitable experience. If necessary, please contact an authorized Service Centre for assistance.

INSTALLATION



Take the utmost care when unpacking, assembling, lifting and setting up the machine as indicated below. Failure to observe these instructions can damage the machine and compromise the operator's safety.

Remove the original packing materials after

positioning them as indicated on the packaging.



All regulations in force concerning safety at work must be complied with when choosing the installation position. In particular, the machine must only be installed and operated in protected environments where there is no risk of exposure to dripping moisture.

IMPORTANT: for the correct and safe operation of the machine, the lighting level in the place of use should be at least 300 lux.

Environmental operating conditions must comply with the following requirements:

- Relative humidity ranging from 30% to 80% (without condensation);
- Temperatures ranging from 0° to +50°C.



The floor must be strong enough to support a load equal to the weight of the equipment plus the maximum load allowed.



The machine must not be operated in potentially explosive atmospheres.

SAFETY REGULATIONS



Failure to comply with the instructions and danger warnings can cause serious injuries to the operator or other persons.

Do not operate the machine until you have read and understood all the danger/warning notices in this manual.

The correct use of this machine requires a qualified and authorized operator. This operator must be able to understand the manufacturer's written instructions, be suitably trained and be familiar with the safety procedures and regulations. Operators are forbidden to use the machine under the influence of alcohol or drugs that could affect his/her physical and mental capacity.

The following conditions are essential:

- read and understand the information and instructions described in this manual;
- have a thorough knowledge of the features and characteristics of the machine;
- keep unauthorized persons well clear of the working area;
- make sure that the machine has been installed in compliance with all relevant standards and regulations in force;
- make sure that all machine operators are suitably trained, that they are capable of using the machine correctly and safely and that they are adequately supervised during work;
- do not touch power lines or the inside of electric motors or any other electrical equipment before making sure that they have been powered off;
- read this booklet carefully and learn how to use the machine correctly and safely;
- Always keep this user manual in a place where it can be readily consulted and do not fail to refer to it.



Do not remove or deface the DANGER, CAUTION, WARNING or INSTRUCTION decals. Replace any missing or illegible decals. If any decals have become detached or damaged, it is possible to obtain them from your nearest reseller.

-Observe the unified industrial accident prevention regulations relating to high voltages and rotating machinery whenever the machine is in use or being serviced.

- Any unauthorized changes or modifications made to the machine automatically release the manufacturer from any liability in the case of damage or accidents resulting from such changes or modifications.



Grounding symbol: This decal, positioned on the rear left side of the machine, indicates where to connect the ground wire.



WEAR PROTECTIVE GLOVE



READ OPERATION MANUAL



WEAR PROTECTIVE GLASSES



POWER OFF THE ELECTRICAL SOURCE OF THE MACHINE DURING MAINTANCE

Meaning of the decals (including the one indicating caution)



Lightning symbol : This decal, positioned on the back of the machine, indicates where to insert the power supply cable and warns the user to pay attention to his safety.



Warning for rotating machine part.

This decal, positioned next to the balancing shaft, reminds the user that this is a rotating part and is therefore dangerous and should not be touched with the hands. The arrow indicates the rotation direction.

DECAL LOCATION DIAGRAM

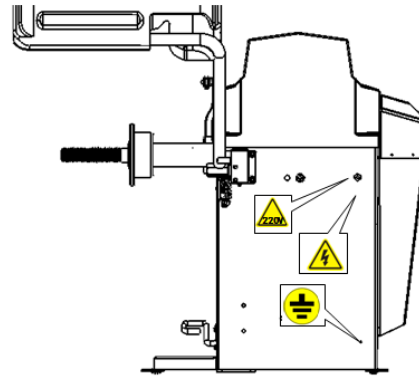

Nameplate

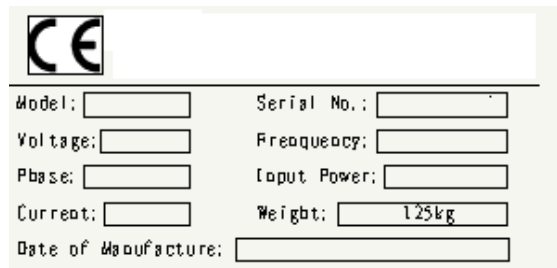

Note: The following information coming from the nameplate

The nameplate is stuck in the center to the top on the rear of the machine. The meaning of each part is in the following:

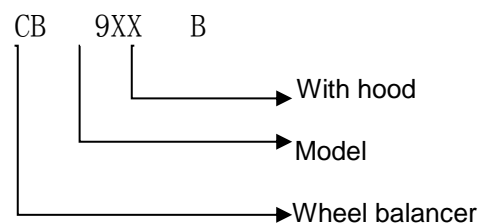

CE certificate



This mark indicates that this model of machine has got CE certificate

Series No the first 3numbers is the abbreviation of the model. The middle 4 is the manufacture date and the

last 4 is company product series number.
 What on the cross line is the name and address of the company and under the cross line not includes the above explained but the rated electrical parameters, such as voltage, frequency, power, phase number & full load current, and the weight and manufacture date of the machine.

If the B has noted in the model of the machine, it means the machine with the protection cover. It means without the equipment of the protection cover if without the note of B.

2 INSTALLATION AND OPERATION

Before installation and use of the wheel balancer, you should carefully read this installation and operation manual. And keep this manual in hand for reference at any time. You should be sure that all the operators have read this manual to guarantee the most perfect functions of the machine and meanwhile the safety.

2.1 MAIN SHAFT INSTALLATION

MAINSHAFT INSTALLATION: Before installation, use the ethyl alcohol and compressed air to clean up the center hole of the shaft and connect part. Use spanner and screw to fix the thread shaft on the balance shaft (Fig2)

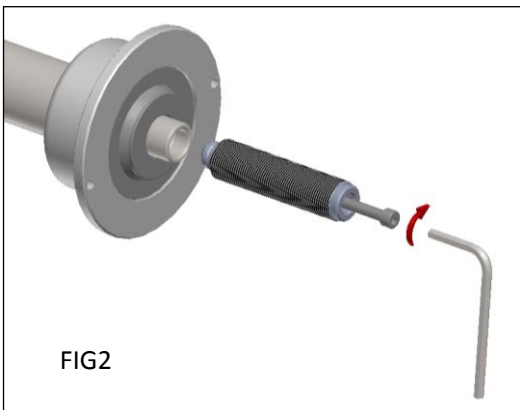

2.2 ELECTRICAL CONNECTION & EARTHING

According to the label on the connection between power cable and body, the power cable connect socket must be grounded with the reliable earth wire.

All the electrical devices installation must be done by the qualified staff. Before installation, please check

If the power system is complying with the technical parameter marked on the nameplate of the machine. The wiring of the machine must have the fuse and the perfect ground protection. And install the electrical Leakage automatic controls switch in the power source. And recommend the application of the stabilizer if the voltage of installation site is unstable.



Any electrical connect in the workshop is only done by the qualified technical staffs and it should meet the enforced regulation.

Any electrical connect must be according to the following:

- Power on the data plate on the machine;
- Voltage decrease cannot exceed 4% of the rated voltage on the data plate when full load (10% when start)

-Operators must:

- Install the plug;
- install 30ma circuit breaker;
- install power cable fuse;
- provide with effective workshop electrical connect to ground;
- prevent the authorized operation and pull out the plug to prolong the working life when not use the machine.
- If the machine directly connected to the power source through the power board not the plug, we should use the qualified staffs to operate.



Perfect ground is necessary for the correct operation. Do not connect the machine with air pipe, water pipe, telephone line and the other unsuitable objects.

3. TECHNICAL PARAMETERS

3.1 FEATURES:

- adopts quality computer with the feature of high intelligence and high stable
- mechanical main shaft adopts high precision bearing driven, wear-resistant, low noise
- press stop key to realize the emergency stop
- full automatic dynamic/static balance check
- balance 3 ALU rim and 1 motorcycle tire
- self-calibration and full automatic trouble diagnosis

3.2 Work principal

Balancing sensor tests the unbalance signal and send it to the terminal of the microprocessor via A/D converter. Processor will calculate the unbalance value through synthesized analysis to the unbalance signal and angle signal of the main shaft.

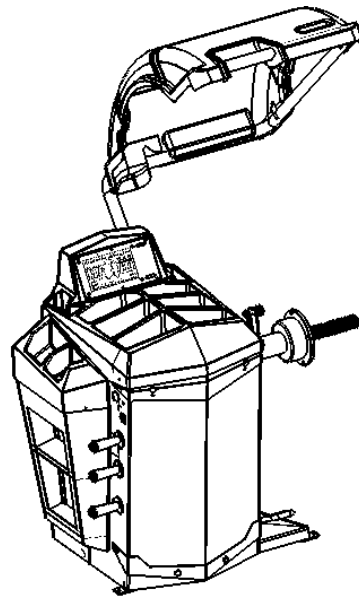

4. INSTALLATION & TRANSPORTATION

4.1 TRANSPORTATION

- Place, carry and store the machine according to the indication of the label on the package carton.
- Store environment: RH20%-95% temperature -10°C-+60°C
- When transport and use the machine, do not pull the rotation shaft, or it will cause the permanent damage.



Do not lift the machine at any other position.

4.1.1 After being sure that the package of your machine is perfect, you can carry the wheel balancer to the installation site. (Fig3). The choice of the installation should comply with the following requirements. The ambient temperature is 0°C-50°C and the RH ≤85%. And the installation site as shown in Fig4

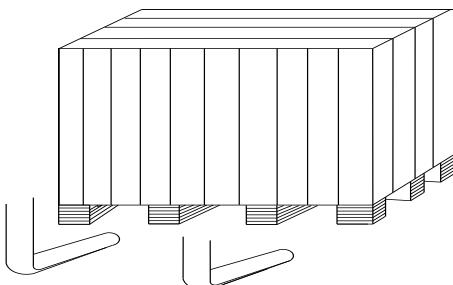

FIG3

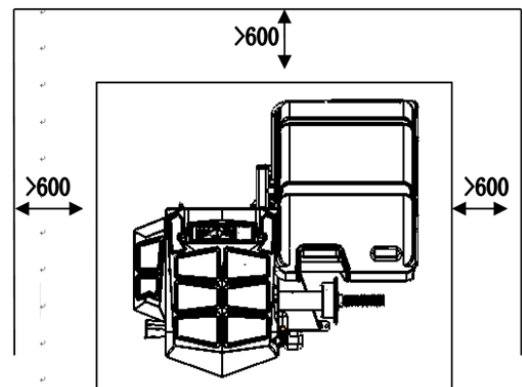
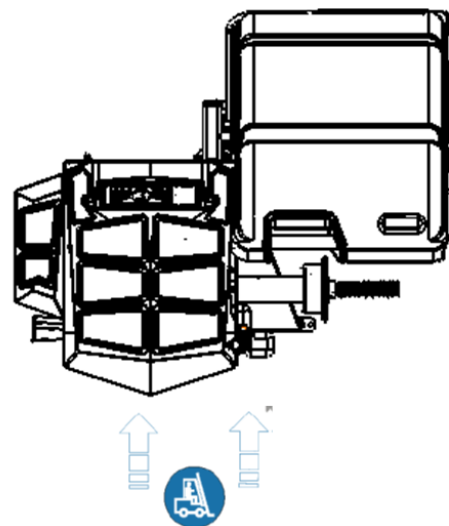

FIG4

4.1.2 Remove the upper cover of the package carton and check and confirm the wheel balancer, spare parts and documents you purchased according to the packing list. If you have any question, please contact with the dealer. Package materials such as plastic, PBV, nail, screw, timber and carton must be placed into a scrap bin to treat according to the local regulation.

4.2 INSTALLATION

Remove the connect bolt. And carry down the wheel balancer to place it on the flat and solid floor. We should store it indoor to avoid it from being exposed to the sunlight for long time and the moisture.

5. SAFETY AND PRECAUTIONS

5.1.1 Before operation, please confirm that you have read the entire warning label and the instruction manual. Not according with the safety instruction can cause the injuries to the operators & bystanders.

5.1.2 Keep your hands and the other parts of your body from the location with the potential danger. Before starting the machine, you must check it there existing the damaged part. If any break or damage, the machine will not be used.

5.1.3 In emergency situation, if the tire not fixed, you should press "STOP" to stop the rotation of the wheels. Adopts high strength protective cover to prevent the tire from flying in any direction and can only fall on the ground to protect the safety of the operators.

5.1.4 Before balancing, operators should check all the tires and wheels to find the possible faults. Do not balance the tires and wheels with fault.

5.1.5 Do not exceed the load capability of the wheel balancer and do not attempt to balance the wheel bigger than the designed dimension.

5.1.6 Wear suitable clothing such as suitable safety suit such as glove, glasses and working suit. Not wear necktie, long hair, loose clothing. The operators should stand beside the machine when operation the machine. Keep from the unauthorized personnel.

5.1.7 Before balancing, you must confirm the installation of the wheel suitable. Before rotation, be sure the nut turns 4turns around the thread shaft and firmly locked on the main shaft.

GENERAL CONDITIONS OF USE

The wheel balancers described in this manual must be used exclusively to measure the extent and position of car wheel unbalances, within the limits specified in the technical data section. Furthermore, models equipped with motors must be provided with a suitable guard.



Any use other than those described in this manual is to be considered improper and unreasonable.



Do not start the machine without the wheel locking equipment.



Protective hood plays the role of prevention and safety.



Do not clean or wash the wheels mounted on the machine with compressed air or jets of water.



Get to know your machine. The best way to prevent accidents and obtain top performance from the machine is to ensure that all operators know how the machine works.



Learn the function and location of all the controls.



Carefully check that all controls on the machine are working properly.



The machine must be installed properly, operated correctly and serviced regularly in order to prevent accidents and injuries.

6. CONFIGURATION

If the wheel is unbalanced, there will have wheel beating and steer wheel vibration during running, affecting the driving, resulting in the steering system to increase the gap and damage the shock absorber and steering components, increase the chance of traffic accidents. The wheel balance can avoid these problems.

Please read this manual carefully before using this equipment to ensure safe operation and normal running of the wheel balancer.

Should avoid unauthorized removal or replacement of the instrument parts;

When repair is required, contact technical service department;

Before balance the wheel, make sure that the wheel is locked reliably on the flange of machine.

Operators should wear tight-fitting work clothes to prevent the rotating parts to catch, non-operating personnel shall not start the instrument;

The wheel balancer can not be used beyond the functional range specified in the manual.

1. Technical index and performance feature

1.1 Technical index:

- The max. wheel weight: 65Kg;
- Motor power: 180W;
- Power supply voltage: 220V 50hz;
- Balance precision: $\pm 1g$;
- Rotation speed: about 200r/min;
- Position precision: 1.5° ;
- One balance cycle: about 8s;
- Rim diameter: 10" ~ 24"(256mm ~ 610mm);
- Noise: less than 70db;

1.2 Performance feature:

- Multiple operation mode to clamp the weight and stick the weight.
- Smart automatic calibration function;
- Automatic trouble diagnosis and protection function;

Suitable for kinds of steel and aluminum rims.

1.3 work environment:

- Environment temperature: 5~50°C;
- Altitude: $\leq 4000M$;
- Relative humidity: $\leq 85\%$

Wheel balancer structure

The wheel balancer includes mechanism and electric:

2.1 mechanism:

The mechanical part consists of the support frame, swing frame and rotating shaft, which are fixed together on the main body.

2.2 electric parts:

- (1) a microcomputer system consisting of a large scale integrated circuit, such as a new ARM microprocessor, a digital tube display and a keyboard.
- (2) speed measurement and positioning system with encoder board and tooth plate;
- (3) two phase asynchronous motor and control electrical circle;
- (4) horizontal and vertical pressure sensor;
- (5) tire protection cover.

7 INSTALLATION OF EQUIPMENT

1. check after unpacking

Unpack the machine and inspect the spare part if it's missing or damaged. If have some questions, contact the distributor in time.

2. machinasm installation

2.1 the balancer must be installed on the firm ground or similar ground. The unfirm ground will cause measurement error.

2.2 there will have 5 space around the wheel balancer in order to operate conveniently.

2.3 should fix the machine by the bolts at the base.

3. balance shaft installation

Install the thread rod onto the main shaft using the bolt M14x140 equipped with the machine then tighten it(Fig 2-1).

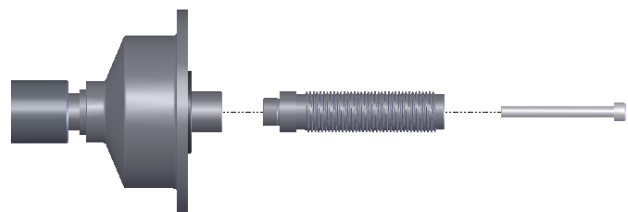

Fig2-1

(note: you can install a tire on the main shaft when tighten the screw and hold the tire by hand to avoid the main shaft rotating together with screw)

4. mount on the wheel

Check and clean the dust and mud and if there are foreign bodies, such as metal and stone, clipped on the surface of the tire. And also check the air pressure of the tire is according with the specified value. Check if there are deformation on the rim positioning surface and installation hole.

Check if there are any foreign bodies in the tire. Take off the original weight.

Positive positioning



Main shaft—wheel –cone—quick lock nut

Negative positioning

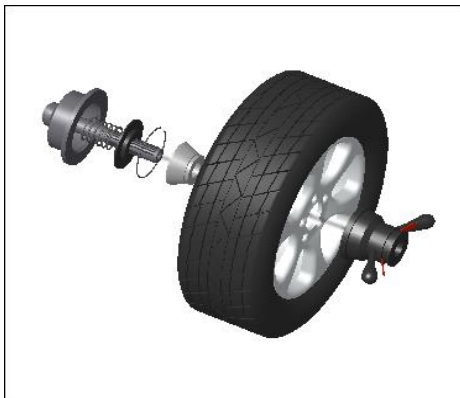

Main shaft—cone—wheel –quick nut with plastic bowl

Note: do not slide the wheel on the thread shaft when install or remove the it to avoid making scratch.

8. Display panel and buttons

1. Display panel and button function

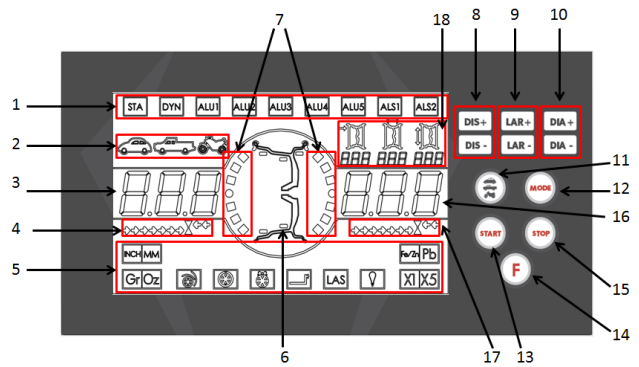

1. ALU mode display
2. CAR/SUV/MOTO mode display
3. Left side value display window
4. Left side weight adhesive indication position
5. Set up display
6. Weight Adhesive position display
7. Unbalanced position indication
8. Distance value adjustment button
9. width value adjustment button
10. Diameter value adjustment button
11. CAR/SUV/MOTO mode selection button
12. ALU mode selection button
13. Start button
14. Function key (Menu button)
15. Stop button
16. Right side value display window
17. Right side weight adhesive indication position
18. Wheel data display

Function:

Press F button for long moment: enter the weight split function when the weight split icon is lit, and enter the OPT when the OPT icon is lit

9. Wheel balance operation

Balance mode operations:

1. According to the position and the way of adding the balance weight, choose the following different balance ways, including the car, SUV, Motorcycle

three modes. Press No.11 key  to choose different wheel modes.

Press No.12 key  to select different balance modes, and each boot will automatically enter dynamic

balance, which is the default mode.

2. Input wheel dimensions

This device can automatically measure the A (or A1, A2) value of the wheel and the D (or D1, D2) value of the wheel. The B value needs to be input manually. (If the machine is equipped with width gauge, then the machine can make automatic measurement).

A (or A1, A2) value and D (or D1, D2) value automatic input method:

Pull out the internal gauge, the equipment will automatically measure (A1) or A value and D (or D1) , pull out the gauge to measure the position and rotate the lean it on the wheel rim, keep about 2 seconds after the position of the gauge, A (or A1) and D (or D1) value is confirmed and automatically input, if the current mode also need to input the value of the A2 and D2 device will automatically enter the condition, the measuring of A2 and D2 will pull out the gauge to above A2 measuring position on the wheel rim, keep about 2 seconds after the position of the gauge, A2 and D2 will confirm and automatically input values.

A (or A1,A2) value and D (or D1, D2) value, manually input method:

Pull out the internal gauge and place it against the wheel measure edge, press the No.8 key to adjust the A value according to the gauge indication result:



According to the rim indication, we can confirm the rim diameter, press No.10 key  , input D value.

To use width caliper to measure the rim width, press



No.9 key  , input B value.



(When you press the button, you need to hear the machine button beep indication sound)

When we use ALS1 and ALS2 modes,

At this moment, the icon   display d1.

Pull out the distance gauge against the rim edge or rim internal area where you want to adhere the balance weight (ALS1 mode, pull the distance gauge against the rim internal area, ALS2 mode, any internal area), read

A1 value, press No.8 key  to input. Then press No.10 key  , input D1 value (rim internal diameter).

Then we press No.9 key to change   from d1 to be d2. In this way we can input the second group data value. At this moment we pull out the distance gauge again and select the second position where we want to adhere the balance weight. According to the distance gauge

measure, press No.8 key  , input A2 value. Then

press No.10 key  , input D2 value. D1, D2 manually measure acquisition method

Method 1: manually input measure directly

Programme Type	Internal diameter da1	External diameter da2
ALS1	Enter the nominal diameter of the rim	Enter the actual diameter da2 measured with the aid of a measuring tape. The measurement must be performed on the balancing plane chosen for da2.
ALS2	Enter the actual diameter da1 measured with the aid of a measuring tape. The measurement must be performed on the balancing plane chosen for da1.	Enter the actual diameter da2 measured with the aid of a measuring tape. The measurement must be performed on the balancing plane chosen for da2.



Method 2: According to the actual diameter after a little adjustment. This method is based on a few adjustments to the rim diameter.

Without manual measurement, this method is more convenient, but the results will be slightly less accurate.

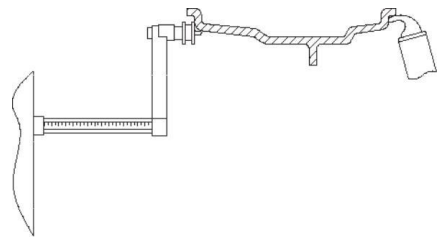

Programme Type	Internal diameter da1	External diameter da2
ALS1	da1 = nominal rim diameter	da2 = nominal diameter - 2.0 inches (or 50mm)
ALS2	da1 = nominal diameter - 1.0 inch (or 25mm)	da2 = nominal diameter - 2.0 inches (or 50mm)

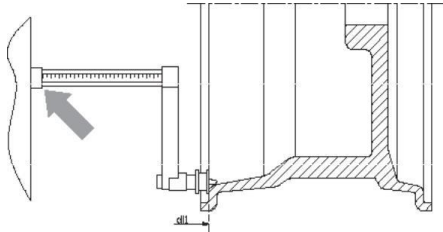

Manual Acquisition of wheel distance in the ALS1 Program

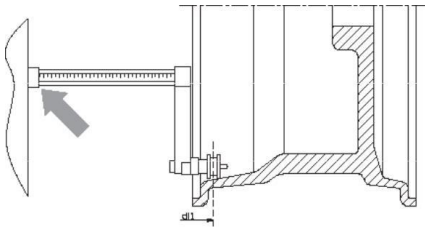

Manual Acquisition of the internal plane distance in the ALS2 Program

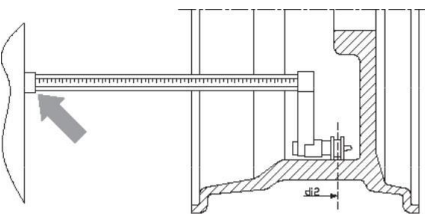

Manual Acquisition of the external plane distance in the ALS1 and ALS2 Program

Manual input of B value:

Press No.10 key, directly manual adjust B value (Except ALS1 and ALS2, the other modes require to input wheel A、B and D values)

If there is a width rule, it can automatically measure the width value. First, pull the ruler to the inside of the tire. When the screen shows the distance and diameter, pull the width ruler to the outside edge of the wheel.

Pause for 2 seconds and the width value will be displayed.

After you hear the beep sound and then return the width gauge to its home position

3. After entering the wheel dimensions, press the START key to launch a spin of the balancing machine. After the wheel stops, the screen shows the unbalanced value

4. Manually rotate the wheel until the unbalanced position indicator light on the inside or outside is on and the buzzer rings, indicating that the unbalanced weight position is here.

There are two ways to apply the unbalanced weight:

4.1 If the balance weight is clamped or applied to the outside of the wheel spokes (such as the outside of ALU2 and ALU4 balance modes), apply the balance weight at the 12 o'clock position of the wheel after the imbalance weight is found

4.2 If a balance weight is applied on the inside of the wheel spokes, the balance weight can be applied by using a pull ruler, or by using a laser indication line

Use the gauge to apply the balance weight. The operation steps are as follows:

Remove the adhesive paper of the stick on weights and expose the adhesive surface of the balance weight upwards, and place the stick on weight clipped on the gauge head and then pull out the gauge

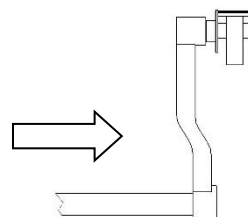

Apply the stick on weight when the weight position indicator light is on

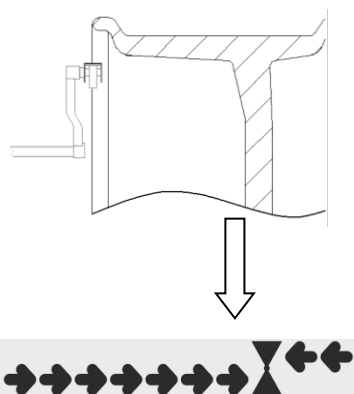

To keep the position of the wheel still, rotate the ruler, the head of the ruler on the rim, and then on the balance weight, it will be pressed on the wheel rim, pull back the ruler

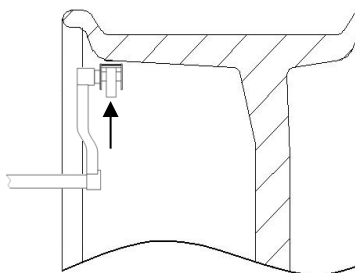

If the laser indicating function is enabled, use the laser indicating line to apply the balance weight. The operation steps are as follows:

Manually rotate the wheel to light up all the indicator lights of unbalanced position on the inside. At this time, the laser indicator line will automatically light up, keep the position of the wheel still, and place the balance weight at the position of the indicator line on the rim.

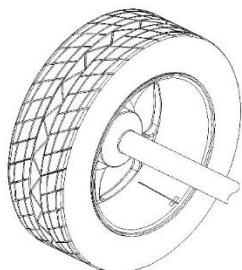

Balance weight application position under each mode:

STD	ALU4

5. After placing the balance weight, press the START key again to run the balancing machine. After the wheel stops, the balance result will be displayed

10. Weight split function

The hidden paste of the balance weight can split the unbalanced weight between the two spokes into two parts, so that the two unbalanced weight after the division fall behind the adjacent two spokes, hiding the unbalanced weight, will not affect the beauty of the wheel.

This function is applicable to several balance modes

such as ALU2, ALU3, ALS1, ALS2, etc. (the icon  will be lit when the hidden weight operation can be performed). Taking ALS2 mode as an example to illustrate the operation method of the hidden weight function.

In ALS2 mode, enter the values of A1, D1, A2 and D2 of the wheel, and run the balancing machine to get the test results. If the external stick on weight position is between the two spokes, then the hidden weight function can be used. The operation steps are as follows:

1. After the unbalanced result is displayed, suppose the unbalanced position on the outside is located between spokes 1 and spokes 2, then long press F key to enter the hidden weight function.

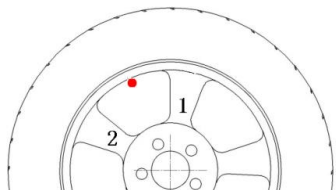

2. Digital tube shows "SPO.--1", pull out the ruler, make it close to the wheel spokes, put the ruler on the top of the rim, turn the wheel, make the ruler in the rear of the wheel spokes 1, keep the wheel position still, pull back the ruler, press the START key to confirm.

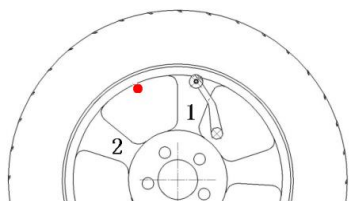

(If the laser indication function is enabled, aim the laser line at spokes 1 and press the START key to confirm)

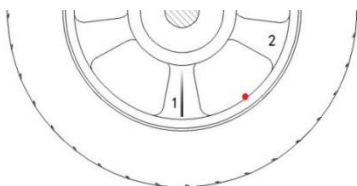

3. Digital tube shows "SPO.--2", pull out the ruler, make it close to the wheel spokes, put the ruler on the top of the rim, turn the wheel, make the ruler in the rear of the wheel spokes 2, keep the wheel position still, pull back the ruler, press the START key to confirm.

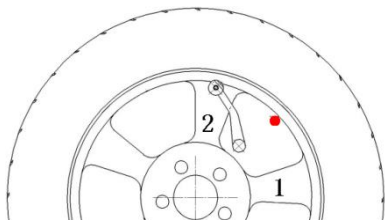

(If the laser indication function is already enabled, aim the laser line at spokes 2 and press the START key to confirm.)

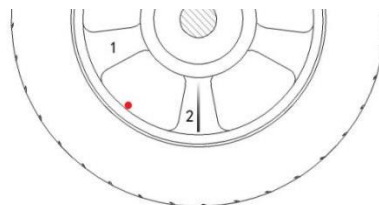

4. At this time, the unbalanced weight on the outside is divided into two unbalanced weights behind the wheel spokes. When you rotate the wheel, you can see the two weights positions displayed. According to the method of application of the balance weight as described in the previous chapter, a balance weight on the inside and two unbalanced weights on the outside are applied onto the rim with the gauge respectively.

5. After apply the balance weight, press the START key again to run the balancing machine. After the wheel stops, the balance result will be displayed.

11. OPT function

When the static imbalance value is too large, and we can use this function, can greatly reduce the tire unbalance, reduce the wheel weights used on the wheel



In DYN mode or static mode, when the measured static imbalance results exceed 30g,  icon will light up, At this time, long press F key to enter OPT function, and "180" is displayed on the right side of the screen, indicating that the position of the rim relative to the tire needs to be rotated 180 degrees.

Make a mark on the axle of the balancing machine and the same position on the rim so that when the wheel is installed again, the rim can be installed back to the same position. Use a tire changer to rotate the tire 180 degrees on the rim, inflate, and mount the wheel on the balancing machine in its original position. Press the

"start" key to rotate the tire. After the rotation is completed, it will display:



Left display window: according to OPT after operation can reduce the percentage of static unbalance value (% symbol display for $\Gamma \perp$)

Right display window: the current static imbalance value, if shown in the figure above, the static imbalance value after the operation can be reduced to about 9 grams ($45 * (1-80\%)$).

Slowly rotate the tire by hand to light up the two lights on the outside of the unbalanced position indicator. At this time, mark 1 on the outside of the tire at 12 o'clock. Then slowly rotate the tire by hand to light the light in the middle of the unbalanced position indicator. At this time, make a mark 2 on the outside of the rim at 12 o'clock. Take off the wheel and assemble the outer tire mark 1 with the outer tire mark 2 on the rim with a tire breaker. In the example above, 80% of the 45 g static imbalance value can be reduced and the remaining imbalance value is about 9g.

12. Calibration operation

The operation steps of setting up the equipment are as follows:

Press F to enter set-up mode

1.100g Calibration

2. Distance & Diameter automatic gauge calibration
3. Width gauge calibration (If the machine is without a width ruler, skip this step)
4. If equipped with a motorcycle adaptor kit, carry out the motorcycle adaptor calibration

1.100g Calibration

1.1 install A wheel that can clip know on weight, input rim data (A, B, D values), and enter into the 100g calibration program.

1.2 press the "START" key to launch a spin of the balancing machine. After the wheel stops, manually rotate the wheel to make the outer indicators lamps are lit up, and hit 100g calibration weight at 12 o'clock on the outside of the wheel.

1.3. Press the "START" key to launch a spin of the balancing machine, and after the wheel stops, remove the 100g weight from the outside, manually rotate the wheel to until the inside indicator lights are lit up, and hit 100g weight on the inside of the wheel at 12 o'clock.

1.4. Press "START" to give a spin of the balancing machine. After the wheel stops, the calibration is completed and the unbalance of the wheel during the last rotation is displayed.

2. Distance & Diameter automatic gauge calibration

2.1. Install a wheel on the balancing machine, and enter the automatic gauge calibration program.

2.2. The left side shows "d16". Press DIA+/- to modify the d value to the diameter value of the installed wheel.

2.3. The left side shows "-15", at this time, pull the ruler out 15cm, press "F" key to confirm, the screen shows "End", and the ruler is finished. Press "F" to return to the main interface.

3. Width gauge calibration

3.1 install a wheel on the balancing machine and enter the width ruler calibration program.

3.2 "b6.2" is displayed on the right side of the screen. Press the LAR+/- key to change the b value to the width value of the mounting wheel.

3.3 pull the ruler to the measuring position of the wheel and place the measuring position of the wheel width ruler on the outside of the wheel.

After about 2 seconds, the screen will prompt the successful calibration of the wheel width ruler and display "END".

Press "F" to return to the main interface directly.

4. Motorcycle adaptor calibration

- 4.1 operate the balancing machine into the motorcycle adaptor calibration. "CAL not".
- 4.2 install the motorcycle adaptor and a motorcycle wheel, press the "START" key to launch a spin, when the balancer stops, rotate the motorcycle wheel 180° relative to MOTO adaptor , then press the "START" key to launch a spin of balancer again.
- 4.3 after the wheels stop, complete the motorcycle adaptor calibration

13. Menu Introduction

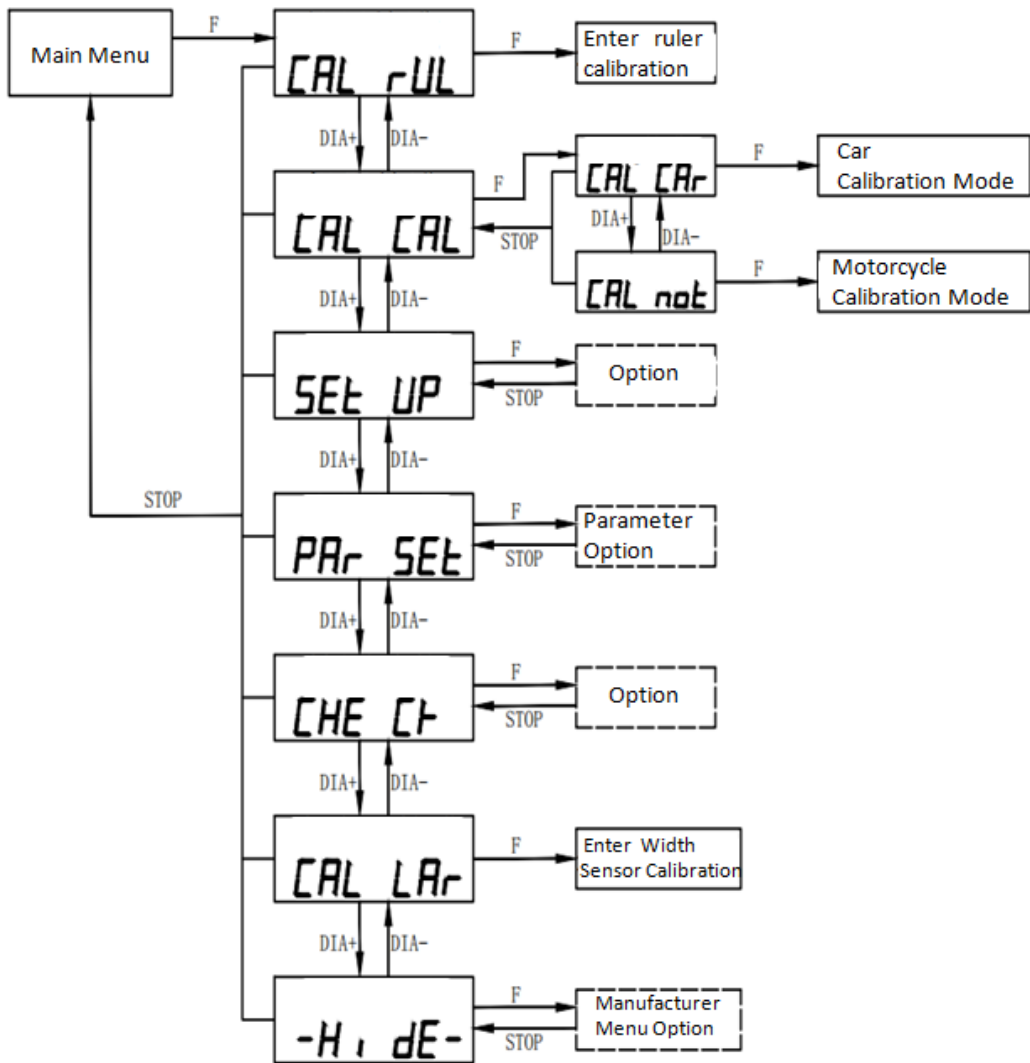

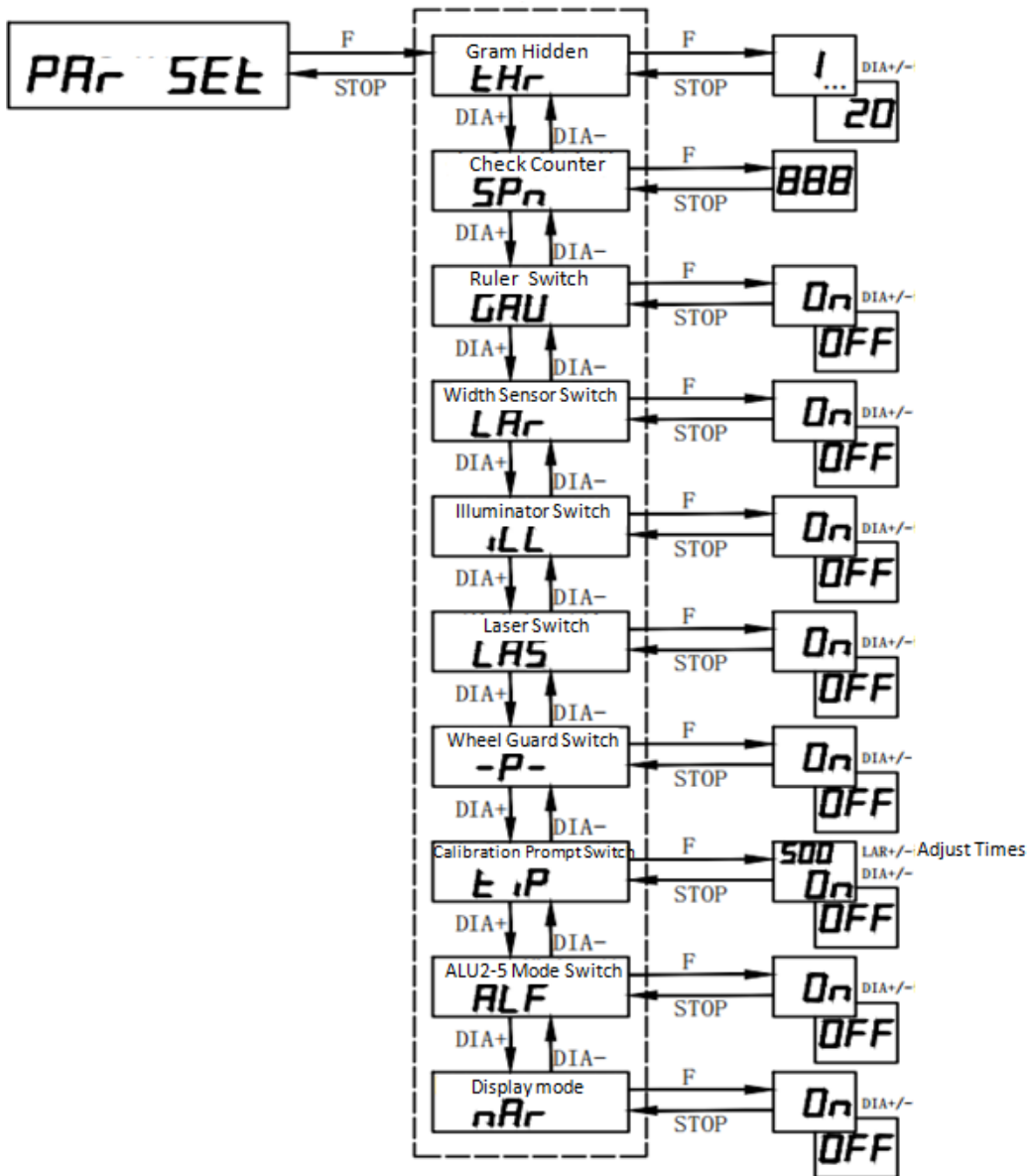
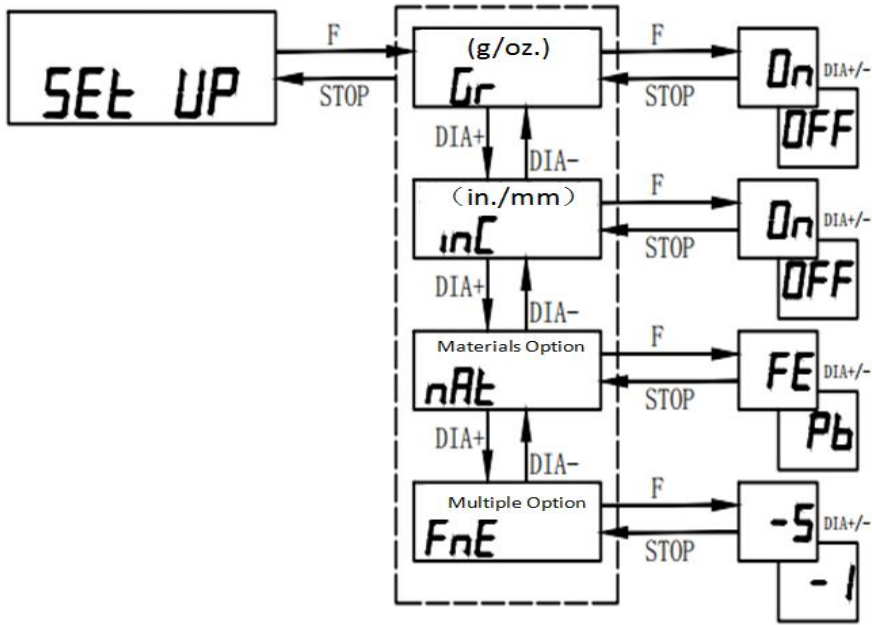

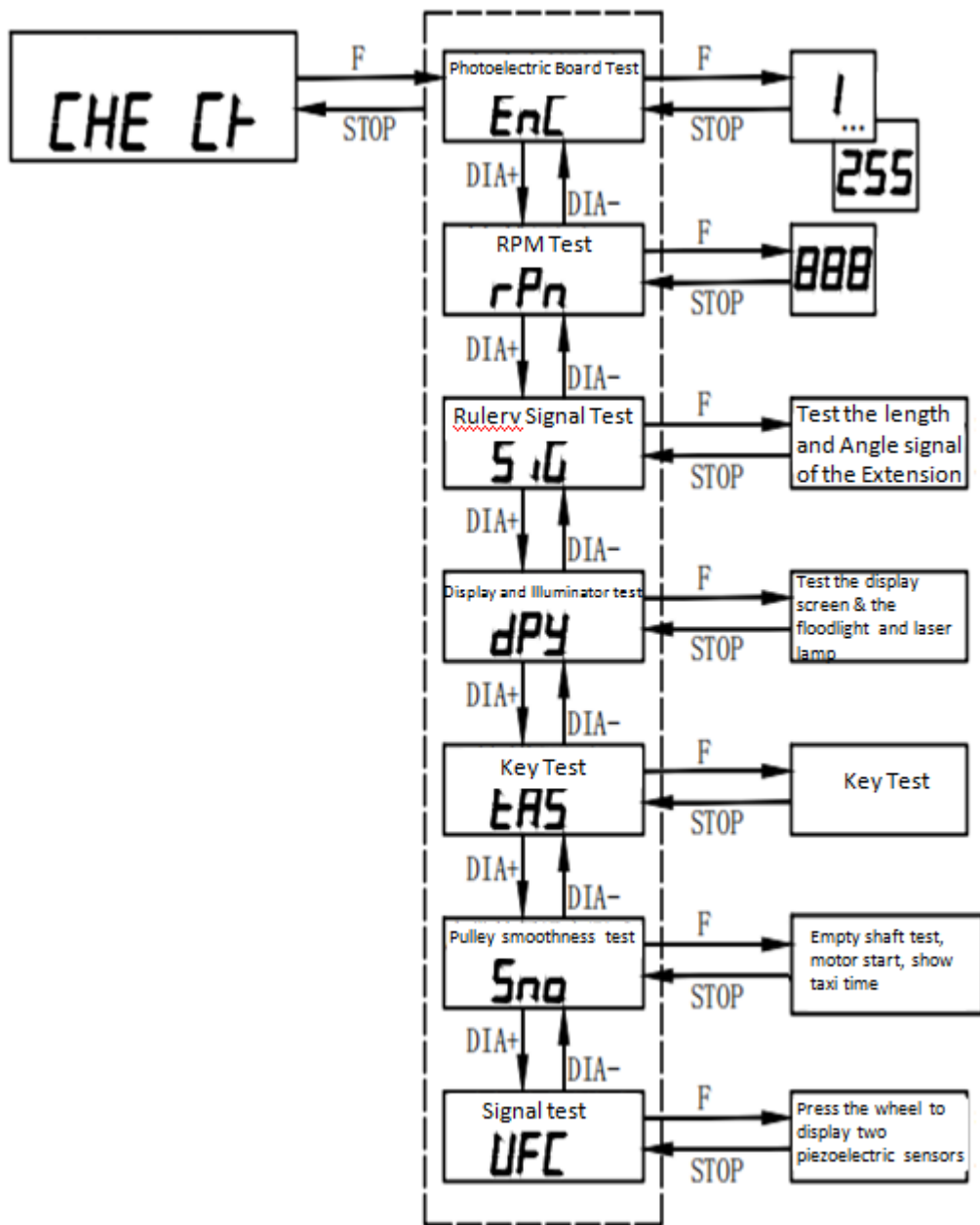

14. ERROR LIST

NO.	Reason	Solution
1	encoder board damaged; power board damaged; motor damaged.	1.If shaft can rotate, change encoder board; 2.The error 1 appears with shaft rotating, maybe power board damaged or motor damaged. 3.The error 1 appears without shaft rotating, maybe power board damaged or motor damaged.
2	Not install the wheel or the belt is too tight.	Install the wheel or adjust the belt.
3	Unbalance weight is too big.	Check if the wheel was installed well or if something on it.
4	Wheel reverse rotating	Check the motor wire is right or not.
5	Not lower down the protection cover.	Adjust it change the stroke switch.
6	Press the stop button by user.	Do another balance operation again.
7	Store chip error	Change power board.
9	Not back the scale.	Back the scale and reset the machine.
10	2 nd setp of calibration without 100g weight.	Do the correct calibration.
11	3 rd step of calibration without 100g weight inside or incorrect sensor connection	Do the correct calibration or check sensor connection or change the sensor.
13	Incorrect length when scale calibration	Do the correct calibration or check the scale wire connection or change scale board.
14	Incorrect angle when scale calibration	Do the correct calibration or check the scale potentiometer wire connection or change the potentiometer.
15	Incorrect parameter	Change power board

	store	
16	The scale is not at the original position when turn on the machine.	Put the scale at original position
17	Choose wrong spokes when hidden the weight	Choose two neighbouring spokes the outside unbalance position.
18	Chip damaged	Change power board
19	grating disk missing teeth	Adjust encoder board position
20	Chip damaged	Change CPU board
22	Length grating without zero signal	Change scale shift board

15. MAINTENANCE



WARNING

The manufacturer will not bear any responsibility in the event of claims resulting from the use of non-original spare parts or accessories.



WARNING

Unplug the machine from the socket and make sure that all moving parts have been locked before performing any adjustment or maintenance operation.



WARNING

Do not remove or modify any part of the machine (except for service interventions).



CAUTION

Keep the work area clean.

Never use compressed air and/or jets of water to remove dirt or residues from the machine. Take all possible measures to prevent dust from building up or rising during cleaning operations.

Keep the wheel balancer shaft, the securing ring nut, the centering cones and flange clean. These components

can be cleaned using a brush previously dipped in

Mobil grease XHP	103
NLGI degree	3
Type of thickener	Li-complex
Color, appearance	Dark blue
Penetration on the processed item 25°, ASTM D 217, mm/10	235
Dropping point, °C, ASTM D 2265	280
Viscosity oil base, ASTM D 445, cSt @ 40°C	100
Change of penetration consistency, ASMT D 1831, mm/10	10
4 spheres test, ASTM D 2266, mm	0.5
4 spheres test, ASTM D 2509, kg	315
Test Timken OK load, ASTM D 2509, lb	45
Stability of oxidization bomb method, ASTM D 942, pressure drop at 100 hours, kPa	35
Corrosion prevention, ASTM D 1743	Passed
EMCOR rust, IP 220, wash away with acid water	0
Rust protection, IP 220-mod, wash away with distilled water	0
Corrosion on copper, ASTM D 4048	1A
Resistance to water spray, ASTM D 4049, % spray	15
Wash away with water, ASMT D 1264, loss (weight%), @ 79°C	5

environmentally friendly solvents.

Handle cones and flanges carefully so as to avoid accidental dropping and subsequent damage that would affect centering accuracy.

After use, store cones and flanges in a place where they are suitably protected from dust and dirt.

Perform the calibration procedure at least once every six months.

LUBRICATION

The only rotating parts of the wheel balancer are the motor and balance shaft. These parts must be periodically lubricated by the operators. If the machine is used very frequently, more than 2 hours per day, we should annually check the bearing. And we will check once a year if the machine is used less than 2 hours a day. When test, do not open up the bearing so you need

insert a screwdriver to test the noise. Due to the function of the bearing is to clamp and support and not suitable to change or remove the grease. In addition, the speed of it is not too fast compared to the machine so no need to change the grease. If you note the run of the bearing abnormal or there is noise, change the bearing. If the customer confirms the bearing is not changed, you only need change the grease. Disassemble the bearing and open up the sealing ring and fill the XHP103 grease. These operations should be guided by the profession personnel and calibrate the machine after changing the grease. If the change of the grease not correctly, it will influence the accuracy of the machine. On this condition, you need to reinstall the sealing ring and assemble the machine and adjust again.

Technical safety card for using grease of wheel balancer

SCRAPPING

If the machine is to be scrapped, separate all electrical, electronic, plastic and ferrous components and dispose of them separately, as provided for by local regulations in force.

ENVIRONMENT INFORMATION

If the machines have the crossed-out bin symbol on their

data plate  , the following disposal procedure must be applied to.

This product may contain substances that can be hazardous to the environment and to human health if it is not disposed of properly.

Electrical and electronic equipment must never be disposed of in the usual municipal waste but must be separately collected for their proper treatment.

The crossed-out bin symbol  , placed on the product and on this page, reminds the user that the product must be disposed of properly at the end of its life.

Thus, the hazardous consequences that non-specific treatments of the substances contained in these products, or improper use of parts of them, may have on the environment or on human health are prevented. Furthermore, this helps to recover, recycle and reuse many of the materials contained in these products.

Electrical and electronic manufacturers and distributors set up proper collection and treatment systems for these products for this purpose.

Contact your local distributor to obtain information on the collection procedures at the end of the life of your product.

When purchasing this product, your distributor will also inform you of the possibility to return another end-of-life piece of equipment free of charge as long as it is of equivalent type and had the same functions as the purchased product.

Any disposal of the product performed in a different way from that described above will be liable to the penalties provided for by the national regulations in force in the country where the product is disposed of.

Further measures for environmental protection are recommended: recycling of the internal and external packaging of the product and proper disposal of used batteries (only if contained in the product).

Your help is crucial to reduce the amount of natural resources used for manufacturing electrical and electronic equipment, minimize the use of landfills for product disposal and improve the quality of life, preventing potentially hazardous substances from being released in the environment.

FIREFIGHTING MEANS TO BE USED

Consult the following table to choose the most suitable fire extinguisher.

Dry materials

Water YES

Foam YES

Powder YES*

CO2 YES*

YES* Use only if more appropriate extinguishers are not at hand or when the fire is small.

Flammable liquids

Water NO

Foam YES

Powder YES

CO2 YES

Electrical equipment

Water NO

Foam NO

Powder YES

CO2 YES



Warning

This table contains general instructions to be used as guidelines for users. All the applications of each type of extinguisher must be obtained from the relevant manufacturer.