

887N

Organization:

To examine:

Approval:

Version: A-01

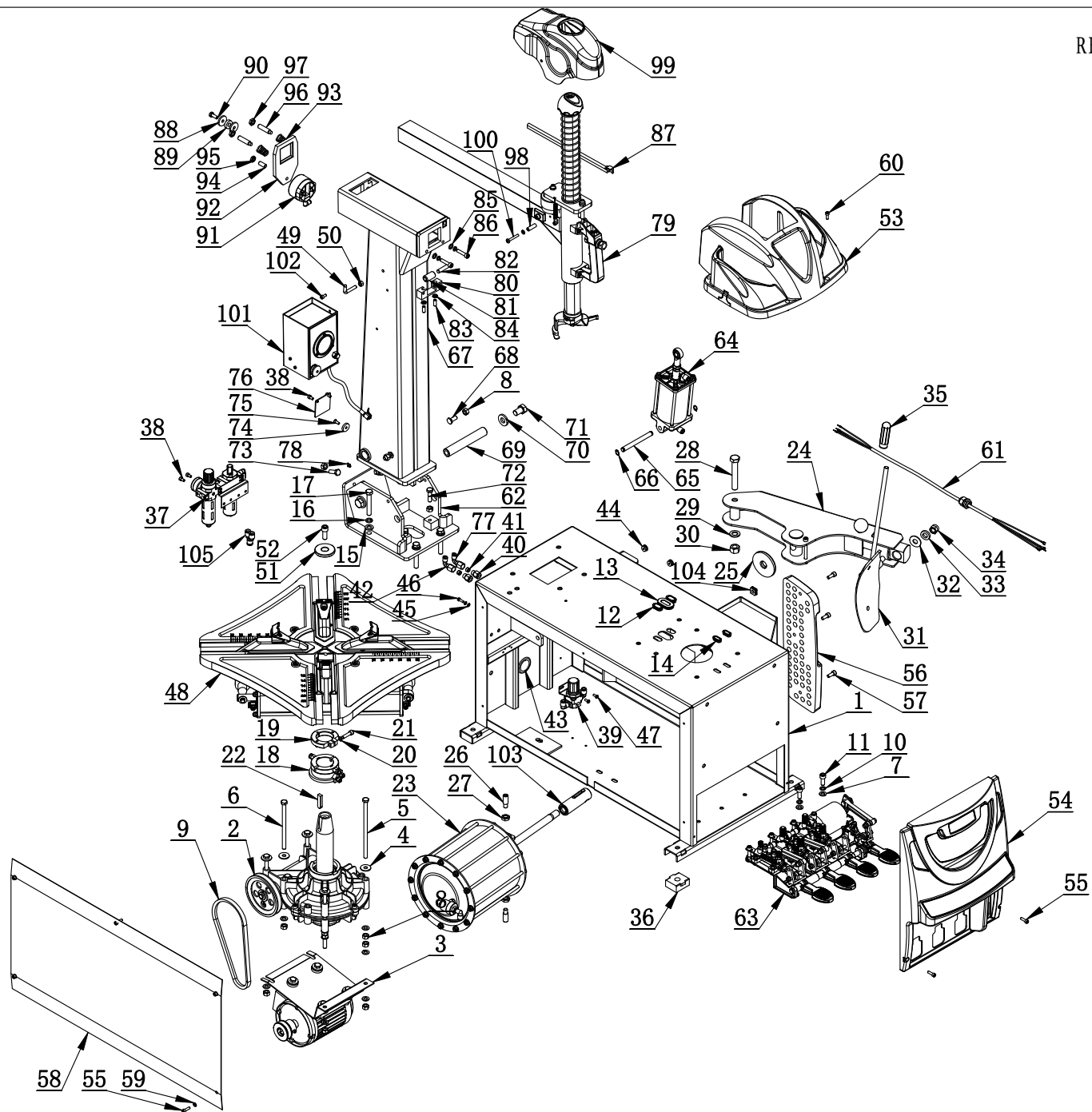

ITEM	PART. No	DESCRIPTION.	QT. Y
1	C-5E-1100000	BODY	1
2	CT-J-4100000	GEARBOX ASSEMBLY	1
3	CT-DJ-0334122	MOTOR	1
4	GB96. 1-10	LARGE WASHER A GRADE	6
5	GB5781-M10X200	BOLT M10X200	4
6	GB5781-M10×160	HEXANGULAR BOLT	2
7	GB95-10	FLAT WASHER	16
8	GB41-M10	HEXANGULAR NUT	20
9	CT-DJ-0000007	TRIANGLE	1
10	GB93-10	STANDARD SPRING WASHER	2
11	GB70. 1-M10×25	INNER HEXA CYLINDRICAL SCREW	2
12	C-54-1000022	PLUG C	2
13	C-54-1000028	PLUG B	1
14	C-54-1000023	PLUG A	2
15	GB95-12	FLAT WASHER	4
16	GB93-12	STANDARD SPRING WASHER	4
17	GB5782-M12×75	HEXANGULAR BOLT	4
18	CT-Q-5000000	ROTATING UNION	1
19	CT-Q-6000000	CLAMP RING	1
20	GB93-8	STANDARD SPRING WASHER	3
21	GB70. 1-M8×30	INNER HEXA CYLINDRICAL SCREW	1
22	GB1096-C12×8×45	COMMON FLAT KEY	1
23	CT-LS-C100000	BEAD BREAKER CYLINDER ASSEMBLY	1
24	CT-B-A000000	BEAD BREAKER	1
25	C-54-1000016	WASHER	1
26	C-54-1000010	SCREWS M14X42	2
27	GB6172. 1-M14	HEXANGULAR THIN NUT	2
28	GB5780-M16×100	HEXANGULAR BOLT	1
29	GB95-16	FLAT WASHER	1
30	GB41-M16	HEXANGULAR NUT	1
31	CT-C-2100000	BEAD BREAKER BLADE	1
32	C-54-1000002	WASHER	1
33	GB955-14	WAVE-FORM SPRING WASHER	1
34	GB889. 1-M14	1-TYPE PREVAILING TORQUE TYPE HEXAGON LOCK NUT	1
35	TC-40-1200022	RUBBER COVER	1
36	C-54-1000005	RUBBER FOOT	4
37	CT-F-2121200	AIR REGULATOR ASSEMBLY	1
38	GB70. 1-M6×10	INNER HEXA CYLINDRICAL SCREW	4
39	H-40-1600000	VALVE	1
40	FPC 8-02	MALE STRAIGHT	2

ITEM	PART. No	DESCRIPTION.	QT. Y
41	C-54-1000027	JOINT SEALING GASKET	2
42	FPLF 8-02	FEMALE ELBOW	1
43	C-61-1000002	CUSHION BUSHING	1
44	C-71-1000027	HELPER RUBBE PLUG	2
45	GB95-5	FLAT WASHER	2
46	GB5782-M5×16-8.8	HEXANGULAR BOLT	1
47	GB818-M5×12-H	CROSS PANHEAD SCREW	2
48	CT-Y-5000000	TURNTABLE ASSEMBLY	1
49	C-71-1000024	INFLATING GUN HOOK	1
50	GB41-M8	HEXANGULAR NUT	1
51	C-54-1000012	PRESS COVER	1
52	GB70.1-M12×30	INNER HEXA CYLINDRICAL SCREW	1
53	C-8E-1000001	TOOL BOX	1
54	C-5E-1000002	FRONT COVER	1
55	GB70.1-M6×20	INNER HEXA CYLINDRICAL SCREW	7
56	C-5E-1000003	RIM SUPPORT	1
57	GB70.1-M8×20	INNER HEXA CYLINDRICAL SCREW	3
58	C-61-1000001	SIDE PANEL	1
59	GB95-6	FLAT WASHER	7
60	GB70.1-M6×16	INNER HEXA CYLINDRICAL SCREW	4
61	CT-E-UN00410	CABLE	1
62	C-8E-1100000	TOP OF BODY	1
63	CT-D-6100000	PEDAL ASSEMBLY	1
64	CT-XD-1000000	PULL-OUT CYLINDER D80X80	1
65	C-71-1000006	PIN SHAFT	1
66	GB894.1-12	SHAFT ELATIC BIG RETAINING RING A-TYPE	2
67	C-80-1200000	COLUMN WELDING DRAWING	1
68	C-71-1000009	BOLT	2
69	C-80-1000004	ROTATION SHAFT	1
70	C-71-1000010	WASHER	2
71	GB5782-M16×25-W8.8	HEXANGULAR BOLT	2
72	GB5781-M10×35	HEXANGULAR BOLT	2
73	GB5781-M10×30	HEXANGULAR BOLT	2
74	C-8E-1000003	WASHER	2
75	GB819.1-M6×16-H	CROSS COUNTERSUNK SCREW STEEL 4.8 GRADE	2
76	C-80-1000010	BLOCK PLATE	1
77	FPLF 6-02	FEMALE ELBOW	1
78	TC-10-8400006	OIL CUP M6	1
79	C-8E-1200000	PUSH AND PULL ARM COMPONENTS	1
80	C-7C-1000004	TELEFLEX SEAT	1

ITEM	PART. No	DESCRIPTION.	QT. Y
81	C-7C-1000005	TELEFLEX	1
82	GB119. 2-10×50	CYLINDRICAL PIN	1
83	GB77-M8×20	INNER HEXA FLAT TERMINUS SET SCREW	2
84	GB6172. 1-M8	HEXANGULAR THIN NUT	2
85	GB95-8	FLAT WASHER	2
86	GB70. 1-M8×35	INNER HEXA CYLINDRICAL SCREW	2
87	C-77-1000009	AIR HOSE CHUTE	1
88	C-77-1000003	CUSHION	2
89	C-77-1000004	RUBBER WASHER	1
90	GB5782-M8×20	HEXANGULAR BOLT	1
91	C-77-1500000	LOCKING CYLINDER ASSY	1
92	C-80-1000005	SQUARE LOCK PLATE	1
93	C-80-1000009	PRESS SPRING	2
94	C-71-1000029	INNER HEXA FLAT TERMINUS SET SCREW	1
95	GB6173-M10×1.0	HEXA THIN NUT	1
96	GB79-M12×50	INNER HEXA CYLINDRICAL TERMINUS SET SCREW	2
97	GB/T6172. 1-M12	HEXANGULAR THIN NUT	2
98	C-77-1000006	PROTECTIVE HOOD LOCK BUSHING	2
99	C-8E-1000002	PROTECTION COVER	1
100	GB818-M6×40-H	CROSS PANHEAD SCREW	2
101	CT-K-3800000	INFLATOR COVER ASSEMBLY	1
102	GB70. 1-M6×12	INNER HEXA CYLINDRICAL SCREW	2
103	C-5B-1400000	LIMIT SET	1
104	C-54-1000015	STOP-UP	1
105	FPY-8	Y-SHAPE INSERT FITTING Φ8	1

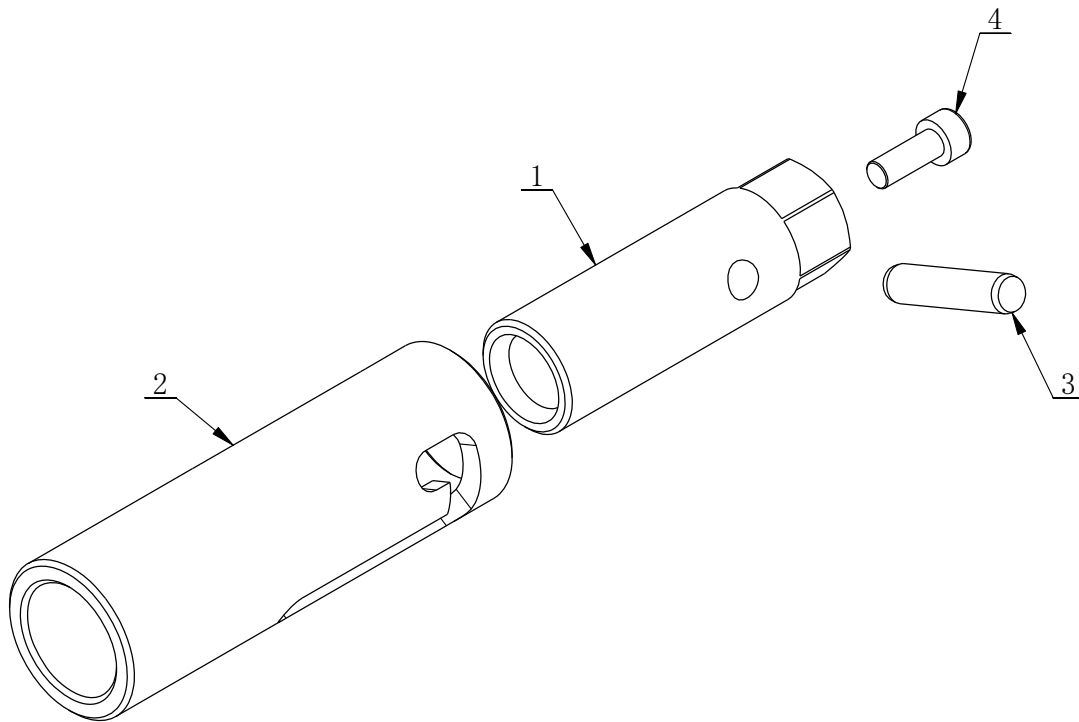

ITEM	PART. No	DESCRIPTION.	QT. Y
1	C-5B-1400001	FIXED AXIS	1
2	C-5B-1400002	REGULATE	1
3	GB119. 2-8×35	CYLINDRICAL PIN	1
4	GB70. 1-M6×16	INNER HEXA CYLINDRICAL SCREW	1

REVISION 15A-01

C-8E-1200000

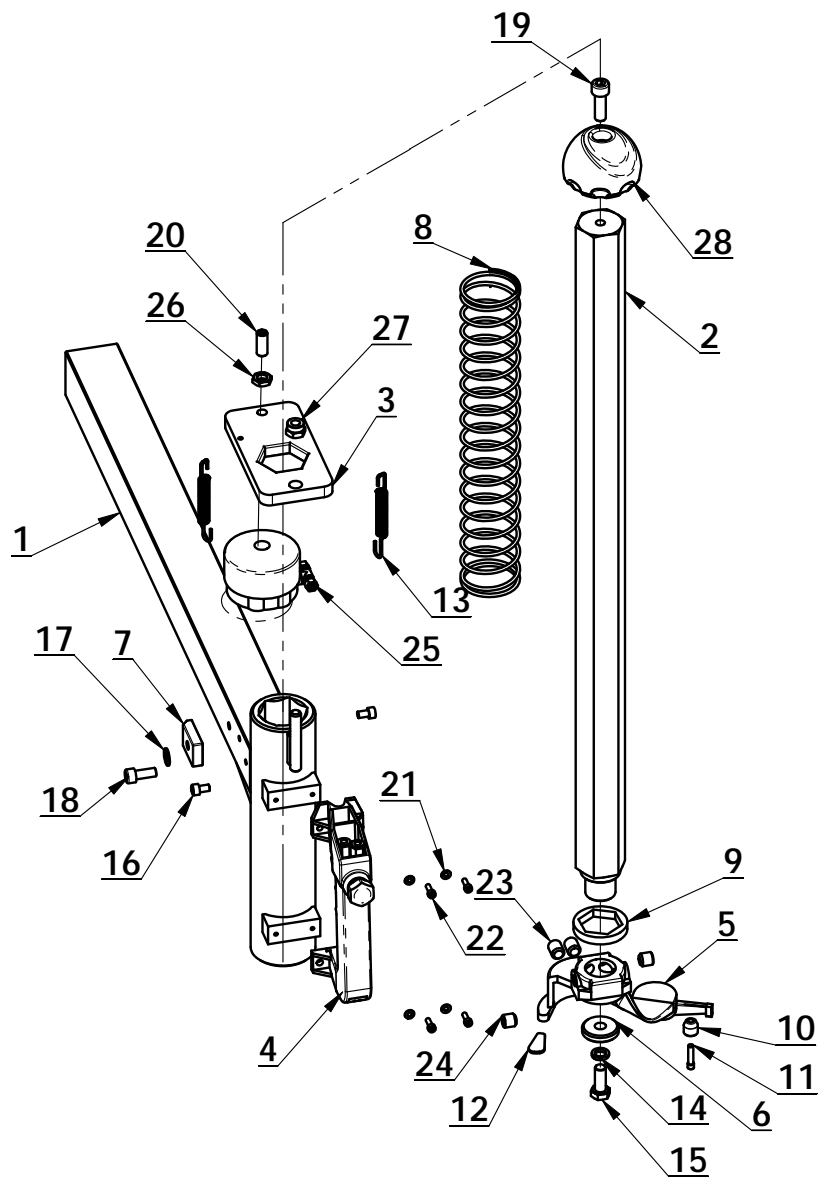

ITEM	PART. No	DESCRIPTION.	QT. Y
1	C-80-1310000	HORIZONTAL ARM WELDING	1
2	C-80-1300001	HEXAGON SHAFT	1
3	C-80-1300002	HEXANGULAR LOCK PLATE	1
4	C-71-1330000	HANDLE CONTROLING VALVE	1
5	C-54-1300004	DEMOUNTING HEAD	1
6	C-54-1300008	PRESS WASHER	1
7	C-71-1300005	POSITIONING BLOCK	1
8	C-54-1300010	VERTICAL SHAFT SPRING	1
9	C-54-1300007	SHOCK ABSORBER WASHER	1
10	C-54-1300009	ROLLER	1
11	C-54-1300006	ROLLER BOLT	1
12	C-54-8000007	PLASTIC COVER	1
13	C-71-1300004	SPRING	2
14	GB93-10	STANDARD SPRING WASHER	1
15	GB5783-M10 × 25-W8. 8	HEXANGULAR BOLT	1
16	GB70. 1-M6 × 10	INNER HEXA CYLINDRICAL SCREW	2
17	GB95-8	FLAT WASHER	1
18	GB70. 1-M8 × 20	INNER HEXA CYLINDRICAL SCREW	1
19	GB70. 1-M10 × 30	INNER HEXA CYLINDRICAL SCREW	1
20	C-71-1000029	INNER HEXA FLAT TERMINUS SET SCREW	1
21	GB95-4	FLAT WASHER	4
22	GB70. 1-M4 × 12	INNER HEXA CYLINDRICAL SCREW	4
23	GB77-M12 × 16	INNER HEXA FLAT TERMINUS SET SCREW	2
24	GB77-M12 × 12	INNER HEXA FLAT TERMINUS SET SCREW	2
25	C-71-1320000	LOCKING CYLINDER ASSY	1
26	GB6173-M10 × 1. 0	HEXA THIN NUT	1
27	GB889. 1-M10	1-TYPE PREVAILING TORQUE TYPE HEXAGON LOCK NUT	1
28	C-5E-1300001	VARTICAL SHAFT COVER	1

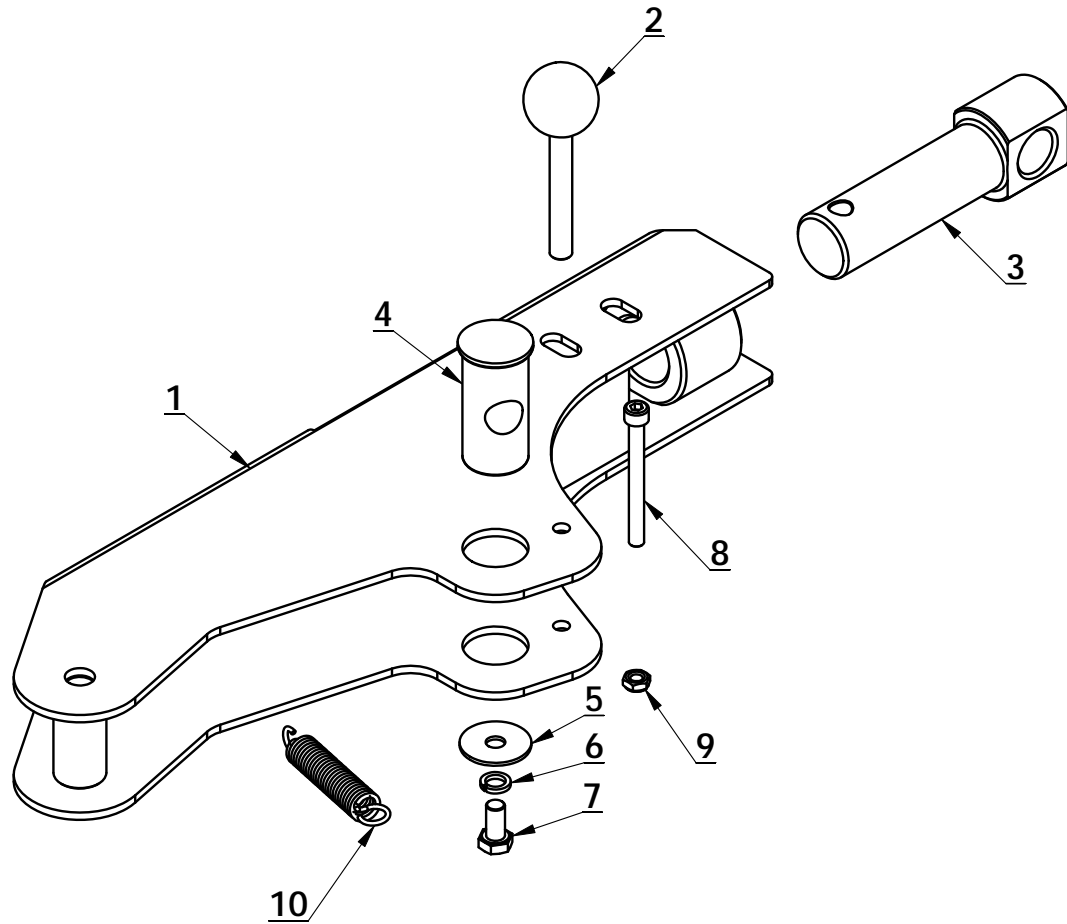

ITEM	PART. No	DESCRIPTION.	QT. Y
1	CT-B-A100000	BEAD BREAKER	1
2	CT-B-A200000	PIN SHAFT	1
3	CT-B-A000001	TURN ROD	1
4	CT-B-A000002	CONNECT ROD	1
5	CT-B-6000003	PAD	1
6	GB93-10	STANDARD SPRING WASHER	1
7	GB5781-M10 × 20	HEXANGULAR BOLT	1
8	GB70. 1-M8 × 80	INNER HEXA CYLINDRICAL SCREW	1
9	GB889. 1-M8	1-TYPE PREVAILING TORQUE TYPE HEXAGON LOCK NUT	1
10	CT-B-2000002	SPRING	1

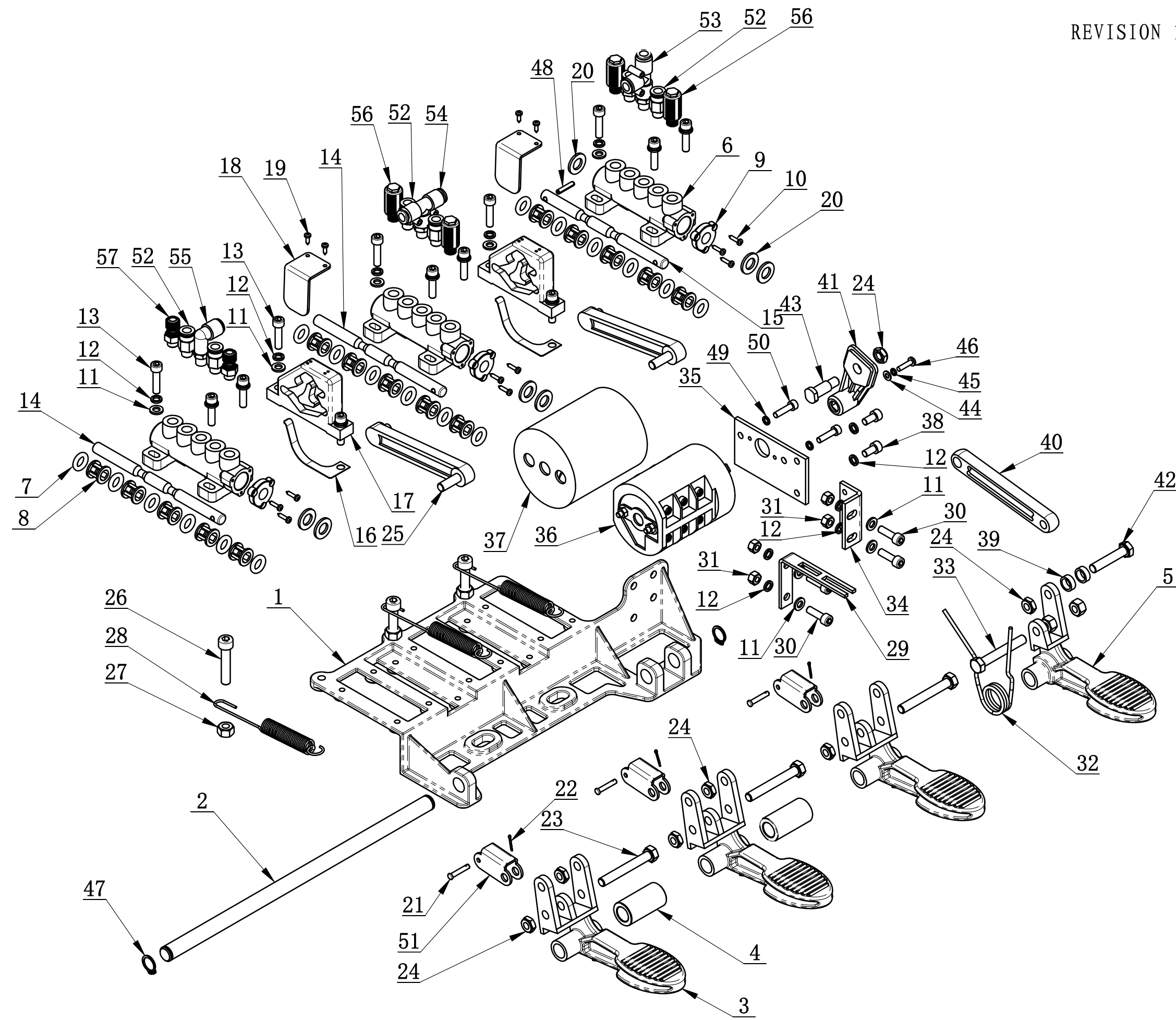

ITEM	PART. No	DESCRIPTION.	QT. Y
1	CT-D-6100001	PEDAL SUPPORT WELDING	1
2	CT-D-6100002	BOTTOM SHAFT	1
3	CT-D-5100003	PEDAL	3
4	CT-D-2100001	SPACER	2
5	CT-D-5100002	PEDAL	1
6	CT-D-1110001	VALVE BODY	3
7	CT-D-1110003	O-RING	18
8	CT-D-1110004	SPACER	15
9	CT-D-1110005	VALVE CAP	3
10	GB845-ST2.9 × 13 H C	CROSS PANHEAD TAPPING SCREW	9
11	GB95-6	FLAT WASHER	17
12	GB93-6	STANDARD SPRING WASHER	19
13	GB70.1-M6 × 25	INNER HEXA CYLINDRICAL SCREW	13
14	CT-D-2600003	VALVE ROD	2
15	CT-D-2600001	VALVE ROD	1
16	CT-D-2100004	SPRING PLATE	2
17	CT-D-1100009	CAM	2
18	CT-D-1100011	CAM BAFFLE PLATE	2
19	GB845-ST2.9 × 9.5 H C	CROSS PANHEAD TAPPING SCREW	4
20	GB95-10	FLAT WASHER	7
21	GB882-4 × 22	PIN SHAFT	3
22	GB91-1.6 × 10	SLOTTED PIN	3
23	GB5782-M8 × 60	HEXANGULAR BOLT	3
24	GB889.1-M8	1-TYPE PREVAILING TORQUE TYPE HEXAGON LOCK NUT	7
25	CT-D-1100008	CAM CONNECTING ROD	2
26	GB70.1-M8 × 40	INNER HEXA CYLINDRICAL SCREW	3
27	GB41-M8	HEXANGULAR NUT	5
28	CT-D-5100007	SPRING	3
29	CT-D-2100010	TORSION SPRING BRACKET	1
30	GB70.1-M6 × 20	INNER HEXA CYLINDRICAL SCREW	4
31	GB41-M6	HEXANGULAR NUT	4
32	CT-D-2100002	TORSION SPRING	1
33	GB5782-M8 × 55	HEXANGULAR BOLT	1
34	CT-D-5100008	SWITCH SUPPORT	1
35	CT-D-5100009	SWITCH SUPPORT	1
36	CT-D-1100018	SWITCH	1
37	CT-D-1100014	SWITCH COVER	1
38	GB70.1-M6 × 12	INNER HEXA CYLINDRICAL SCREW	2
39	CT-D-2100005	SPACER	2
40	CT-D-2100011	CONNECTION ROD	1

ITEM	PART. No	DESCRIPTION.	QT. Y
41	CT-D-1100010	REVERSE LEVER	1
42	GB5781-M8 × 40	HEXANGULAR BOLT	1
43	CT-D-2100012	ROTATION SHAFT	1
44	GB95-4	FLAT WASHER	1
45	GB93-4	STANDARD SPRING WASHER	1
46	GB818-M4 × 16-H	CROSS PANHEAD SCREW	1
47	GB894.1-14	SHAFT ELATIC BIG RETAINING RING A-TYPE	2
48	GB879.1-4 × 20	ELASTIC CYLINDRICAL PIN, HEAVY	1
49	GB93-5	STANDARD SPRING WASHER	2
50	GB70.1-M5 × 20	INNER HEXA CYLINDRICAL SCREW	2
51	CT-D-5100005	CONNECT ASSEMBLY	3
52	FPC 8-01	MALE STRAIGHT	6
53	FPD 8-01	MALE RUN TEE	1
54	FPB 8-01	MALE BRANCH TEE	1
55	FPL 8-01	INSERT ELBOW $\Phi 8$, R1/8	1
56	FSK 01	PLASTIC PARTICLE SILENCER	4
57	FJSR 01	BRASS REGULATOR SILENCER	2

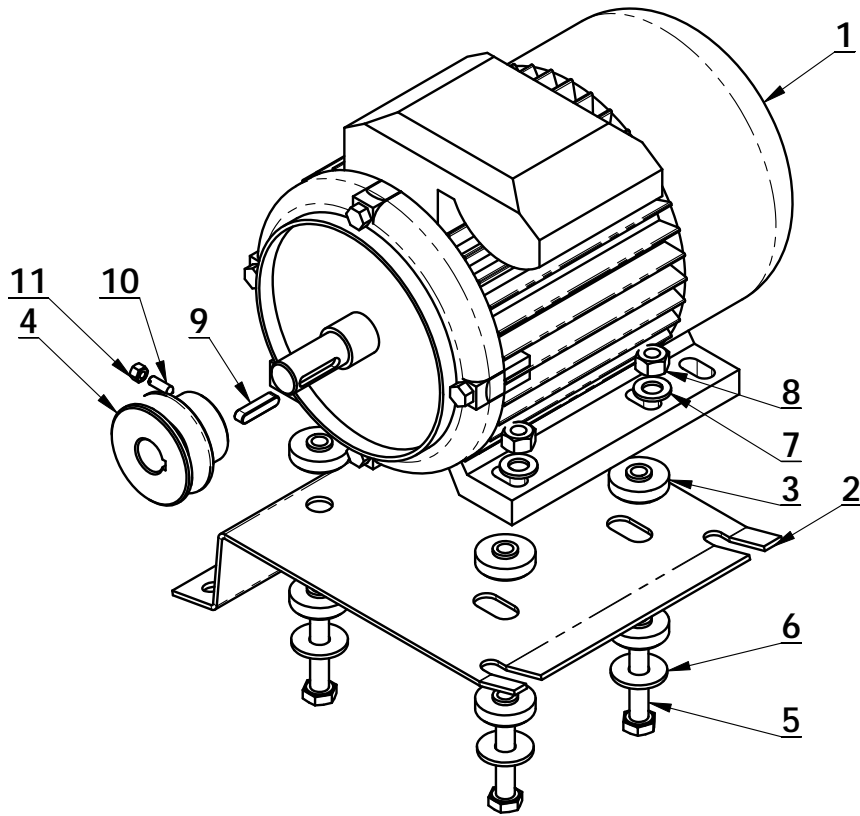

ITEM	PART. No	DESCRIPTION.	QT. Y
1	CT-DJ-0018112	MOTOR	1
2	CT-DJ-0000001	MOTOR SUPPORT	1
3	CT-DJ-0000002	RUBBER WASHER	8
4	CT-DJ-0000003	MOTOR BELT PULLEY	1
5	GB5781-M10×50	HEXANGULAR BOLT	4
6	GB96. 2-10	LARGE WASHER C GRADE	4
7	GB95-10	FLAT WASHER	4
8	GB41-M10	HEXANGULAR NUT	4
9	GB1096-6×6×28	COMMON FLAT KEY	1
10	GB71-M5×16	SLOTTED CONIC HEAD SET SCREW	1
11	GB41-M5	HEXANGULAR NUT	1

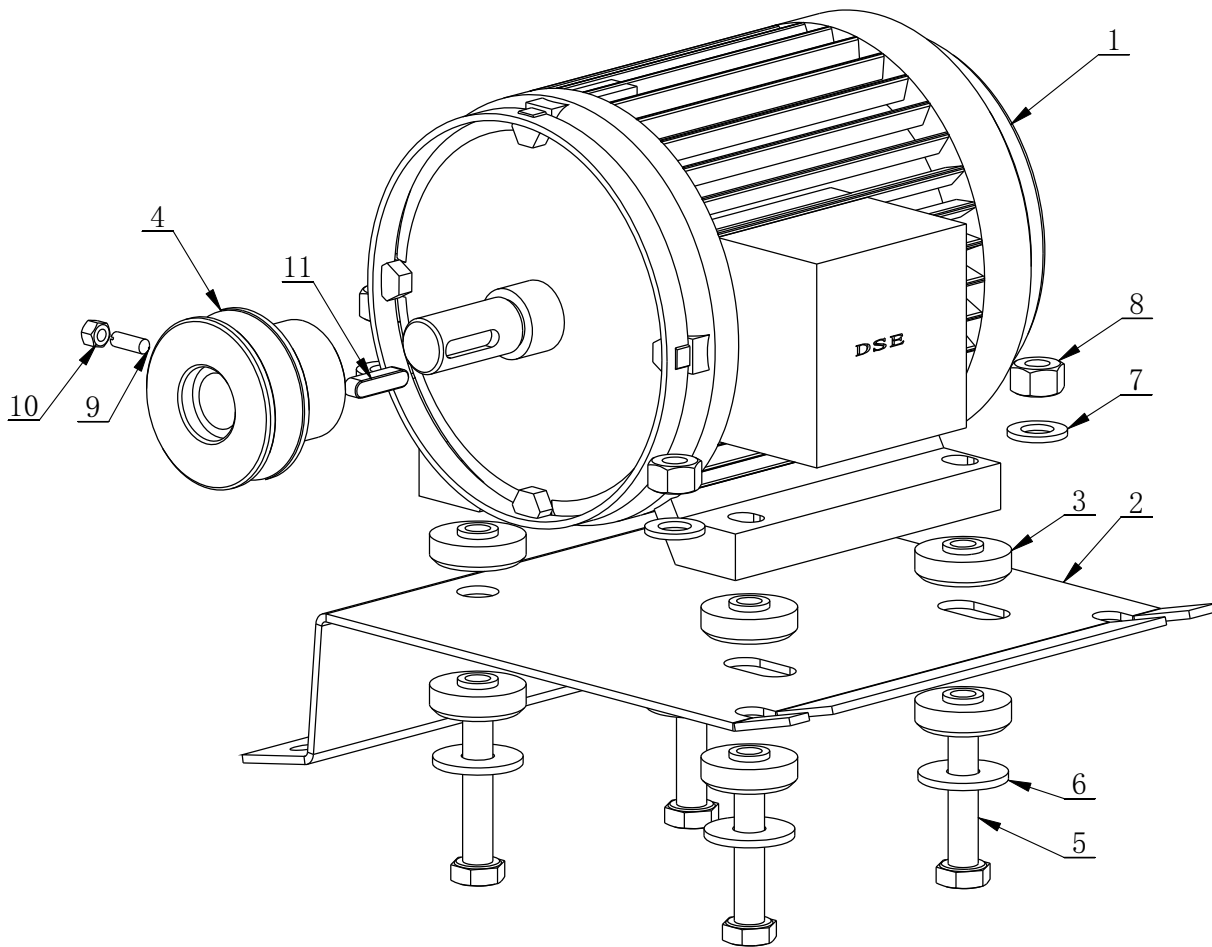

ITEM	PART. No	DESCRIPTION.	QT. Y
1	CT-DJ-0034122	MOTOR (0.75KW 380V 50Hz 3P)	1
2	CT-DJ-0000001	MOTOR SUPPORT	1
3	CT-DJ-0000002	RUBBER WASHER 220V MOTOR BELT PULLEY ($\Phi 58 \times 40$)	8
4	CT-DJ-0000003		1
5	GB5781-M10 \times 50	HEXANGULAR BOLT	4
6	GB96.2-10	LARGE WASHER C GRADE	4
7	GB95-10	FLAT WASHER	4
8	GB41-M10	HEXANGULAR NUT	4
9	GB71-M5 \times 16	SLOTTED CONIC HEAD SET SCREW	1
10	GB41-M5	HEXANGULAR NUT	1
11	GB1096-6 \times 6 \times 25	COMMON FLAT KEY	1

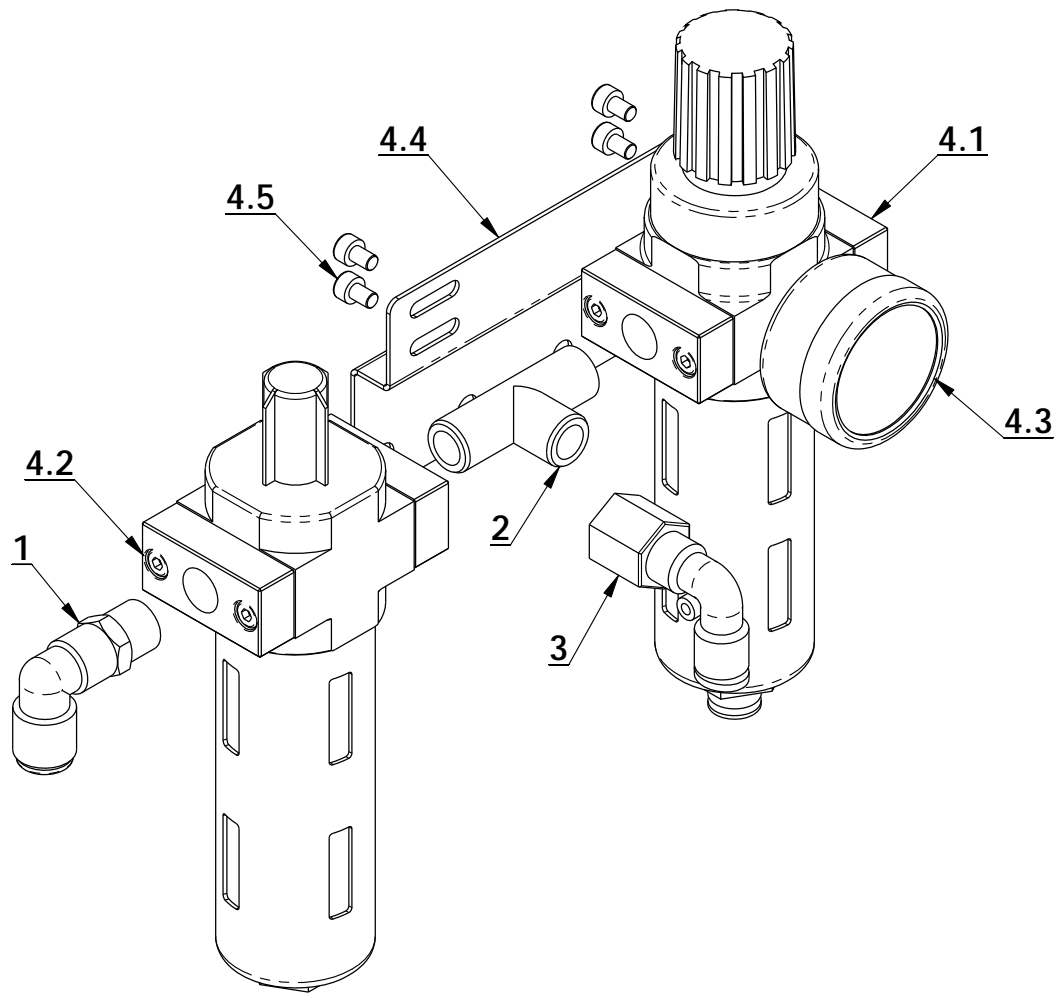

ITEM	PART. No	DESCRIPTION.	QT. Y
1	FPL 8-02	INSERT ELBOW $\Phi 8$, R1/4	1
2	PEH 02-02	FAMALE UNION TEE	1
3	FPLF8-02	INSERT ELBOW $\phi 8$,R1/4	1
4	CT-F-2000100	AIR REGULATOR	1
4.1	CT-F-2000010	PRESSURE ADJUST VALVE AND WATER CUP	1
4.2	CT-F-2000020	OIL CUP	1
4.3	CT-F-2000003	PRESSURE GAUGE	1
4.4	CT-F-2000040	AIR REGULATOR BRACKET	1
4.5	GB/T70. 1- M4×6	INNER HEXA CYLINDRICAL SCREW	4

CT-J-4100000

REDUCER CT-J-4100000

REVISION 15A-01

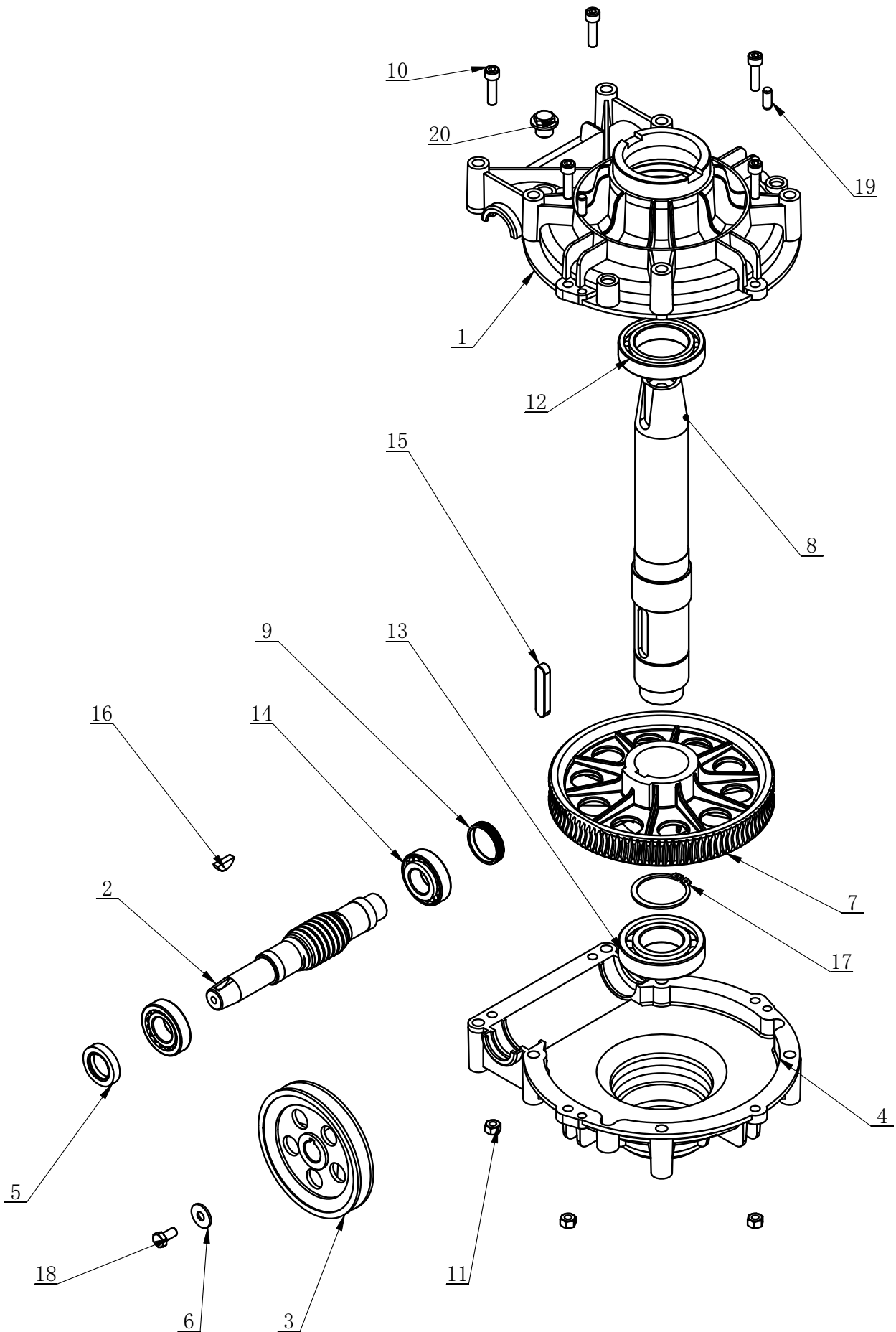

ITEM	PART. NO	DESCRIPTION.	QT. Y
1	CT-J-0000006	GEARBOX TOP	1
2	CT-J-0000004	WORM ROD	1
3	CT-J-0000008	BELT PULLEY	1
4	CT-J-0000005	GEARBOX TOP	1
5	FB25-40 GB13871.92	SEALED RING	1
6	GB96.2-8	LARGE WASHER C GRADE	1
7	CT-J-0000003	WORM	1
8	CT-J-0000002	WORM SHAFT	1
9	CT-J-0100000	CAP	1
10	GB70.1-M8×30	INNER HEXA CYLINDRICAL SCREW	5
11	GB41-M8	HEXANGULAR NUT	5
12	GB276-6010	DEEP GROOVE BALL BEARINGS	1
13	GB276-6208	DEEP GROOVE BALL BEARINGS	1
14	GB297-30205	CYLINDRICAL BALL BEARING	2
15	GB1096-12×8×56	COMMON FLAT KEY	1
16	GB1099.1-6×9×22	COMMON SEMI-CIRCULAR KEY	1
17	GB894.1-50	SHAFT ELATIC BIG RETAINING RING A-TYPE	1
18	GB5781-M8×16	HEXANGULAR BOLT	1
19	GB119.1-8×20	CYLINDRICAL PIN	2
20	TC-10-1400013	BOLT	1

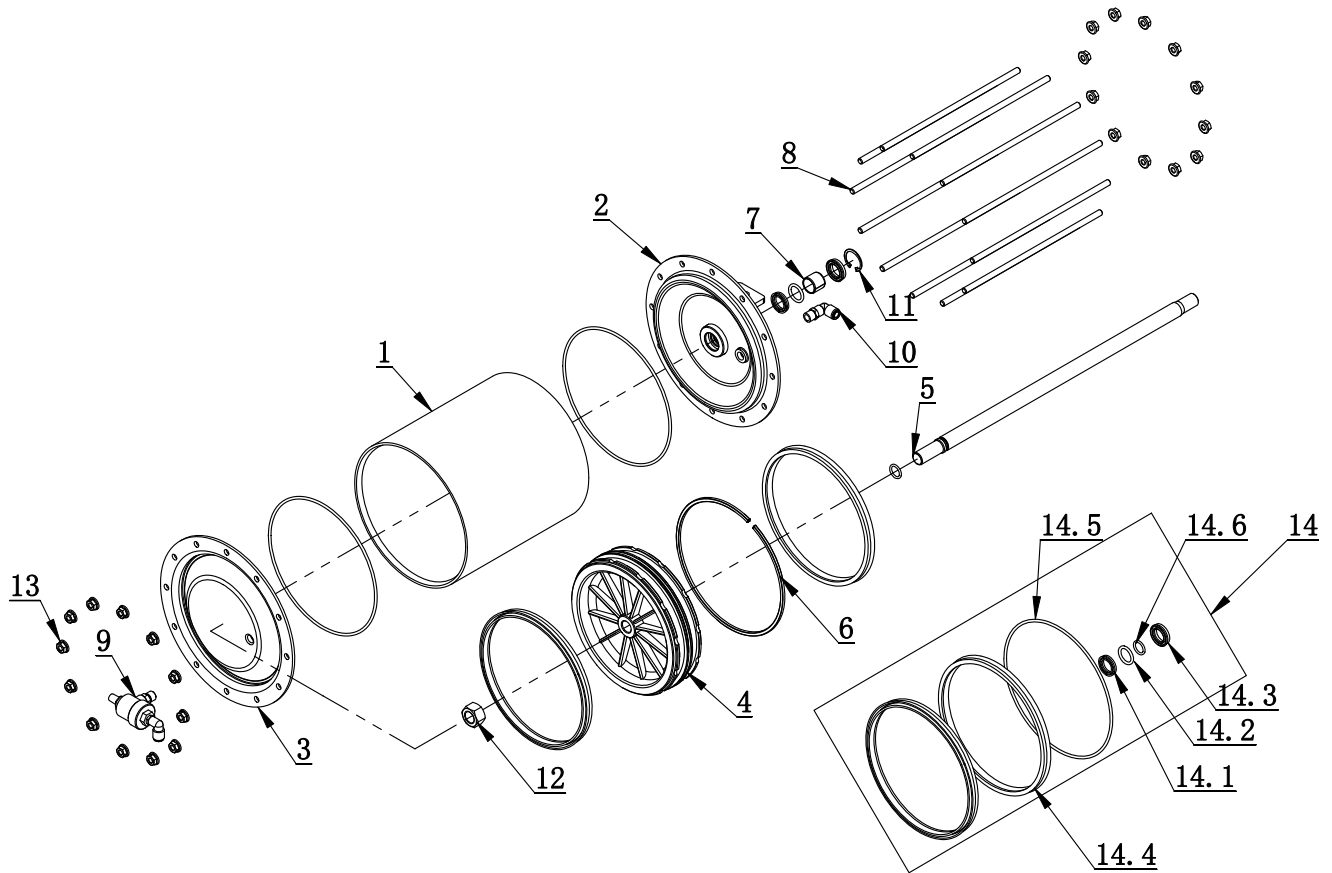

ITEM	PART. No	DESCRIPTION.	QT. Y
1	CT-LS-B100001	CYLINDER BODY	1
2	CT-LS-B110000	CYLINDER FRONT COVER	1
3	CT-LS-B100002	CYLINDER REAR COVER	1
4	CT-LS-B100003	PISTON	1
5	CT-LS-C100001	CYLINDER PISTON ROD	1
6	CT-LS-B100005	PISTON SUPPORT RING	1
7	CT-LS-B100006	SELF-LUBRICATING BEARING	1
8	CT-LS-B100007	FASTENING BOLT	12
9	CT-LS-B120000	QUICK DEFLATE VALVE ON COVER	1
10	S6520 8-1-4	INSERT ELBOW $\Phi 8$, R1/4	1
11	GB893.2-30	ELASTIC RETAINING RING B-TYPE	1
12	GB6171- M18 \times 1.5	NUT THIN TOOTH	1
13	GB6177.1-M8	HEXA FLANGE NUT	24
14	CT-LS-B130000	CYLINDER SEALING PARTS ASSEMBLY	1
14.1	CT-LS-2400002	SEALING RING	1
14.2	GB3452.1-20 \times 3.55-G	HYDRAULIC-PNEUMATIC RUBBER O-RING G TYPE	1
14.3	CT-Y-0160007	SEAL-ROD, CYLNDR	1
14.4	CT-LS-B100008	Y-RING	2
14.5	GB3452.1-195 \times 3.55-G	HYDRAULIC-PNEUMATIC RUBBER O-RING G TYPE	1
14.6	GB3452.1-15.5 \times 2.65-G	HYDRAULIC-PNEUMATIC RUBBER O-RING G TYPE	1

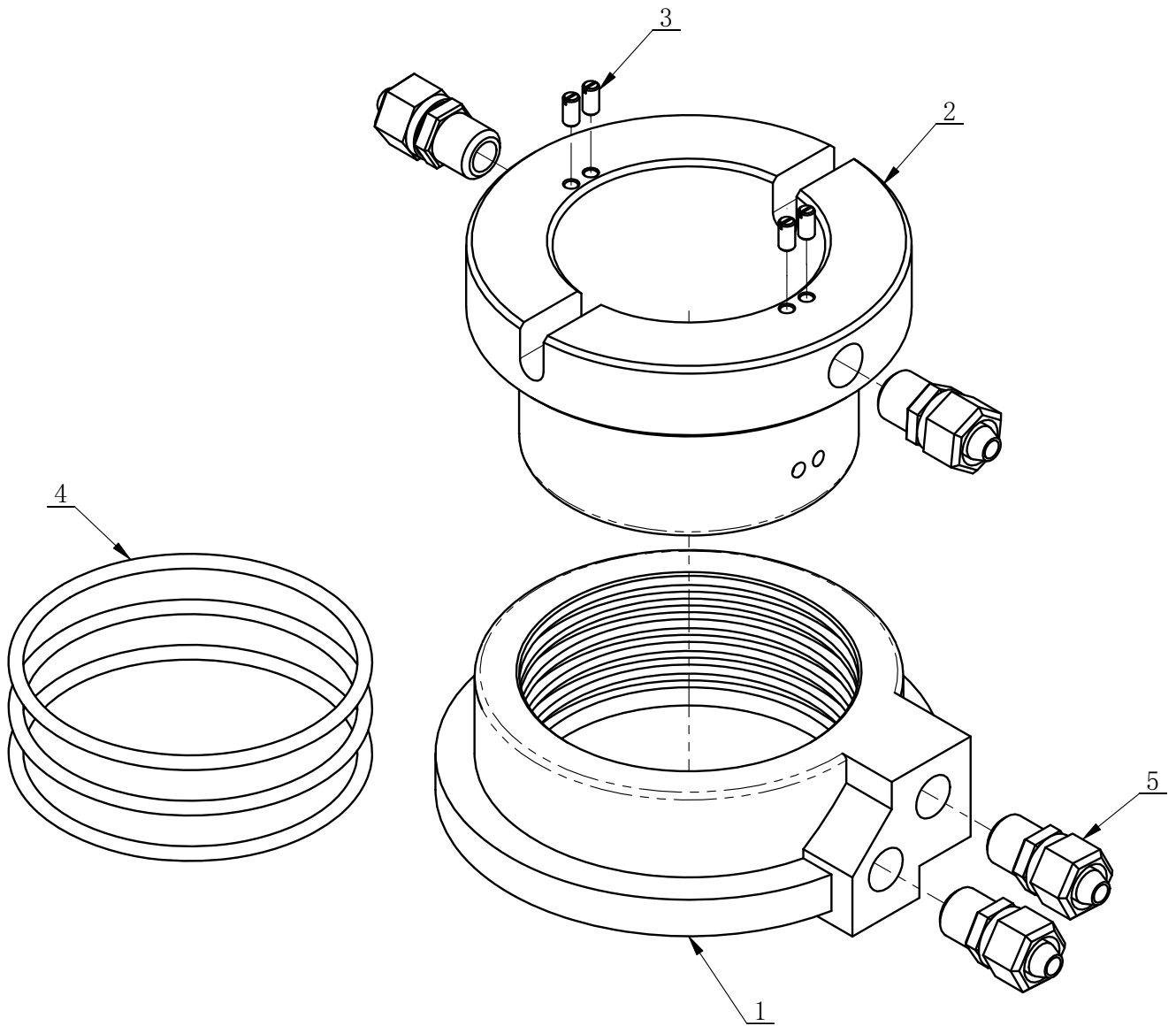

ITEM	PART. No	DESCRIPTION.	QT. Y
1	CT-Q-1000001	AIR GUIDE EXTERNAL BUSHING	1
2	CT-Q-1000002	AIR GUIDE ROTATION BUSHING	1
3	GB73-M3×6	SLOTTED FLATTEN HEAD SET SCREW	4
4	GB3452. 1-60×2. 65-G	HYDRAULIC-PNEUMATIC RUBBER O-RING G TYPE	3
5	PCS8-01	MALE STRAIGHT NUT	4

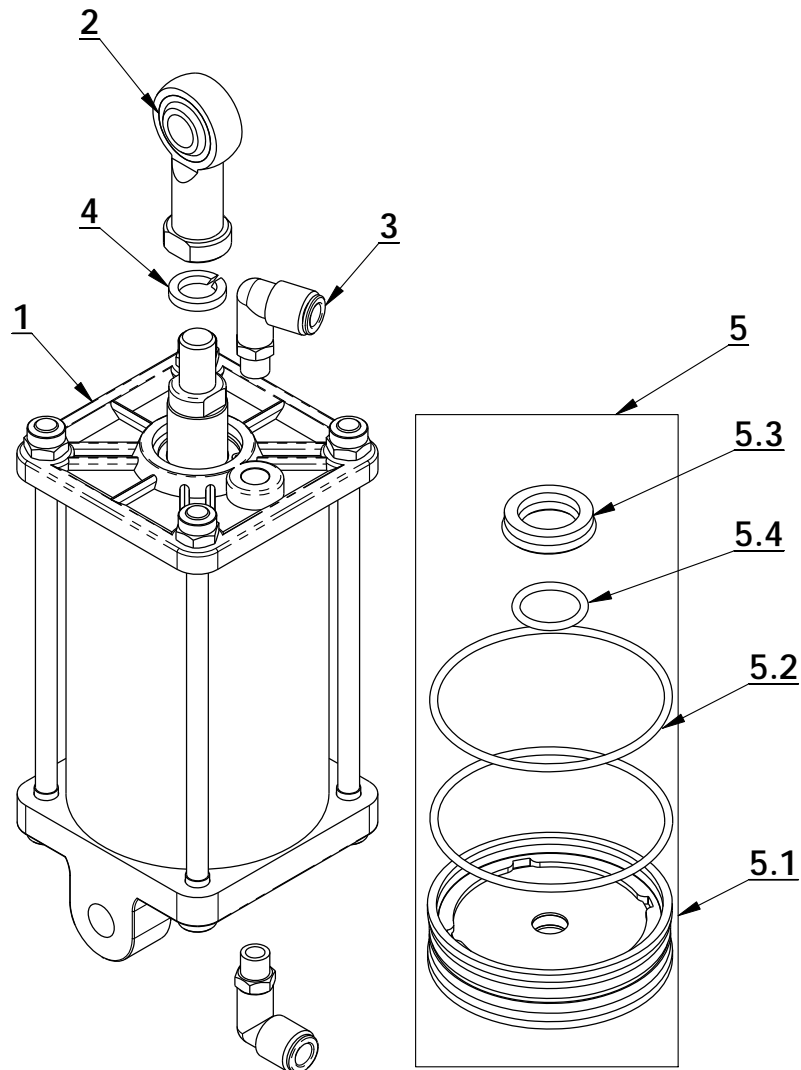

ITEM	PART №	PART.No	DESCRIPTION.	QT. Y
1		CT-XD-1100000	AIR CYLINDER	1
2		CT-XD-1000007	BEARING JOINTS	1
3	5509158	FPL 8-01	INSERT ELBOW $\Phi 8$, R1/8	2
4		GB93-12	STANDARD SPRING WASHER	1
5		CT-XD-2100000	CYLINDER SEALING PARTS ASSEMBLY	1
5.1	6000047	CT-Y-4120006	PISTON	1
5.2		GB3452.1-75×2.65	HYDRAULIC-PNEUMATIC RUBBER O-RING G TYPE	2
5.3		CT-Y-0160007	SEAL-ROD, CYLNDR	1
5.4		GB3452.1-20×2.65	HYDRAULIC-PNEUMATIC RUBBER O-RING G TYPE	1

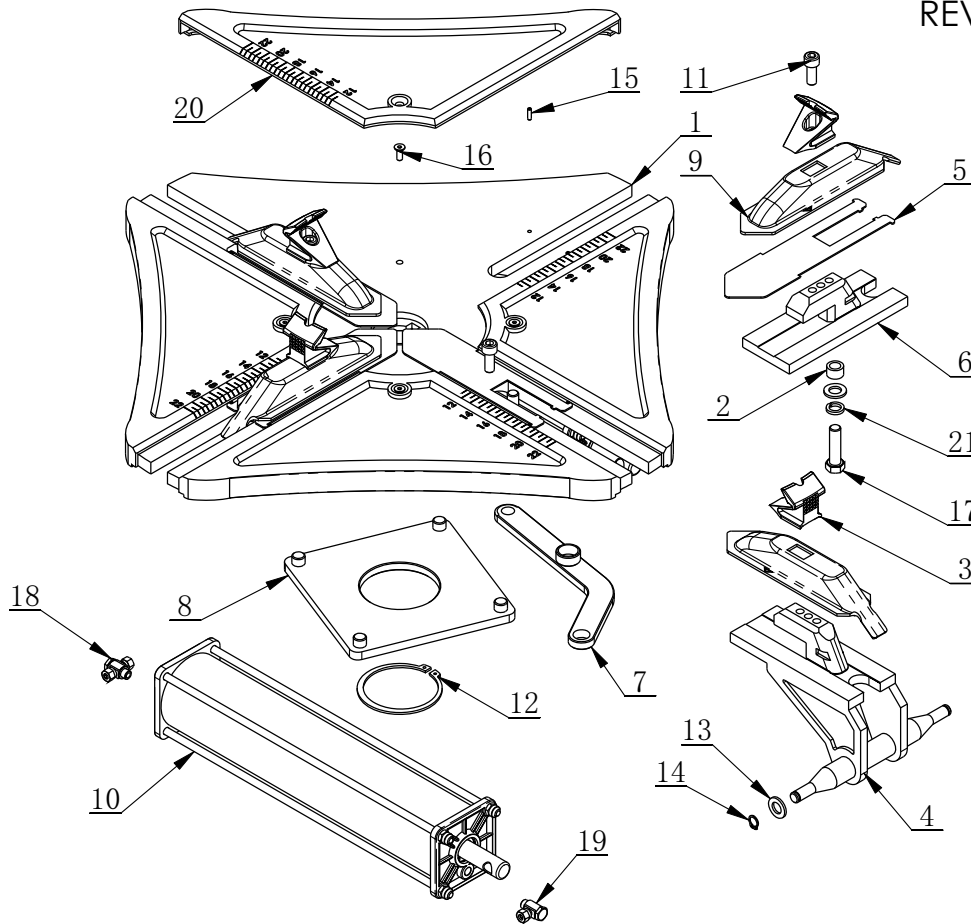

ITEM	PART. No	DESCRIPTION.	QT. Y
1	CT-Y-5040000	TURNTABLE	1
2	CT-Y-0100003	SPACER	4
3	CT-Y-5000002	CLAMP	4
4	CT-Y-5060000	BRACKET-CYLINDER	2
5	CT-Y-5000004	WEARABLE WASHER	4
6	CT-Y-5000003	PRESS BOARD	2
7	CT-Y-5020000	CONNECTION PLATE	4
8	CT-Y-5030000	SQUARE TURNTABLE	1
9	CT-Y-5000001	SLIDE COVER	4
10	CT-Y-5010000	CYLINDER ASSEMBLY D80X350	2
11	GB70. 1-M10×25	INNER HEXA CYLINDRICAL SCREW	4
12	GB894. 1-85	SHAFT ELATIC BIG RETAINING RING A-TYPE	1
13	GB95-12	FLAT WASHER	8
14	GB894. 1-12	SHAFT ELATIC BIG RETAINING RING A-TYPE	4
15	GB879. 1-4×14	ELASTIC CYLINDRICAL PIN HEAVY	8
16	GB70. 3-M6×16	INNER COUNTER SUNK SCREW	4
17	GB5782-M12×45	HEXANGULAR BOLT	4
18	CT-Y-0100008	HINGE ELBOW Φ8	2
19	CT-Y-0100007	HINGE ELBOW Φ6 R1/8"	2
20	CT-Y-5000005	PROTECTIVE COVER	4
21	GB93-12	STANDARD SPRING WASHER	4

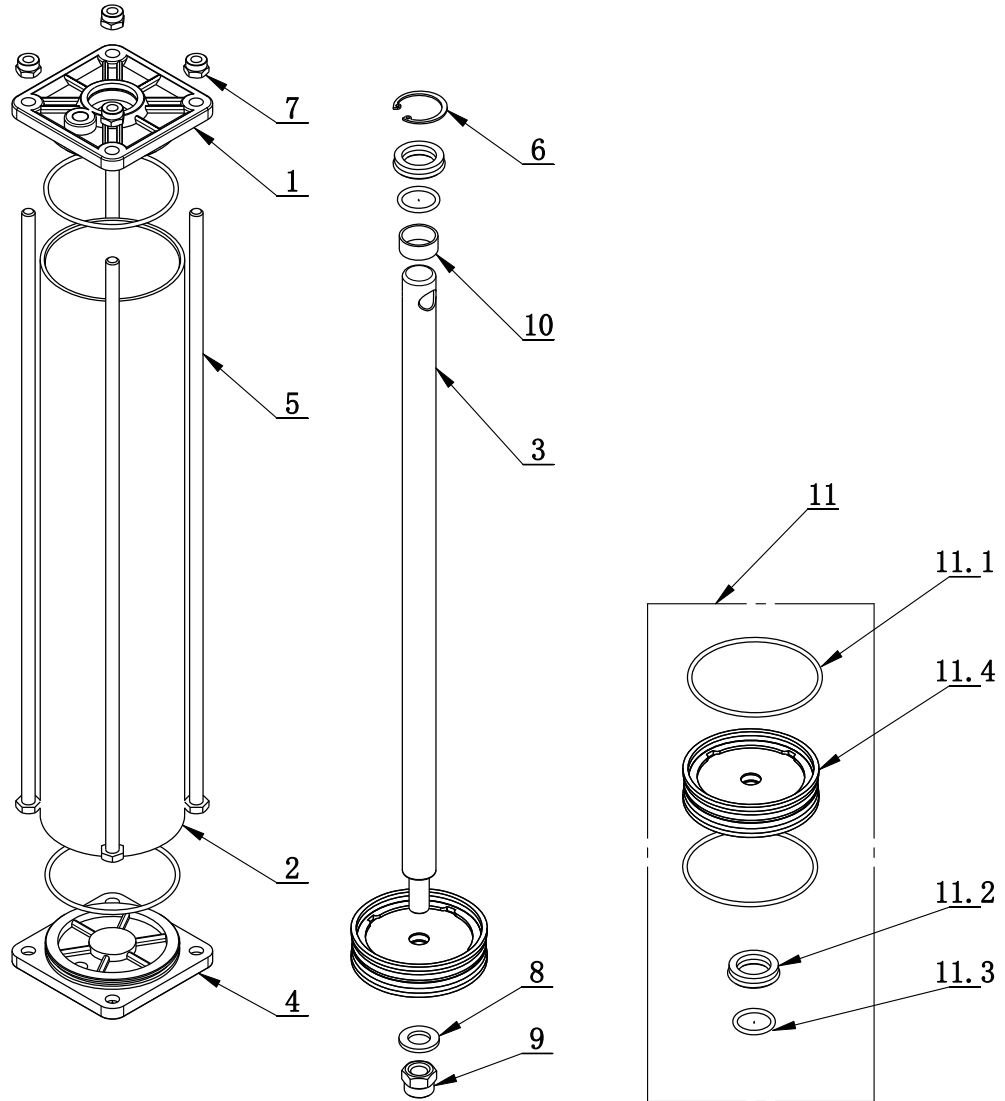

ITEM	PART. No	DESCRIPTION.	QT. Y
1	CT-Y-4120004	CYLINDER FRONT COVER	1
2	CT-Y-5010001	CYLINDER 80MM	1
3	CT-Y-5010002	SHAFT-CLYDR	1
4	CT-Y-4120005	CAP-BASE, CYLNDR	1
5	CT-Y-5010003	BOLT	4
6	GB893. 1-30	ELASTIC RETAINING RING A-TYPE	1
7	GB889. 1-M8	1-TYPE PREVAILING TORQUE TYPE HEXAGON LOCK NUT	4
8	GB95-12	FLAT WASHER	1
9	GB889. 1-M12	1-TYPE PREVAILING TORQUE TYPE HEXAGON LOCK NUT	1
10	JH1 2010	BEARING-SLIDE	1
11	CT-Y-4121000	CYCLINDER SEALING PARTS ASSEMBLY	1
11.1	GB3452. 1-75×2. 65-G	HYDRAULIC-PNEUMATIC RUBBER O-RING G TYPE	2
11.2	CT-Y-0160007	SEAL-ROD, CYLNDR	1
11.3	GB3452. 1-20×2. 65	HYDRAULIC-PNEUMATIC RUBBER O-RING G TYPE	1
11.4	CT-Y-4120006	PISTON	1

ADJUSTING VALVE

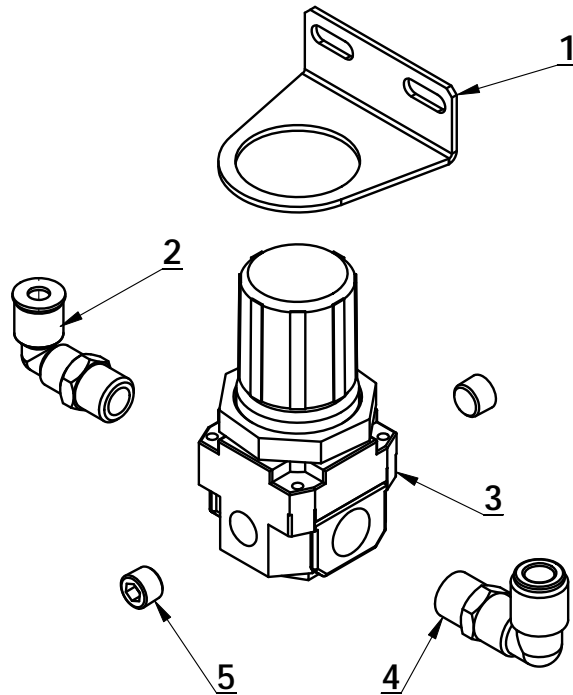

ITEM	PART. No	DESCRIPTION.	QT. Y
1	H-40-1600002	VALVE HOLDER	1
2	FPL 6-02	MALE ELBOW	1
3	H-40-1600001	PRESSURE ADJUST VALVE	1
4	FPL 8-02	INSERT ELBOW $\Phi 8$, R1/4	1
5	FPS 01	PLUG MAIN BLOCK	2

CT-K-3800000

REVISION 15A-01

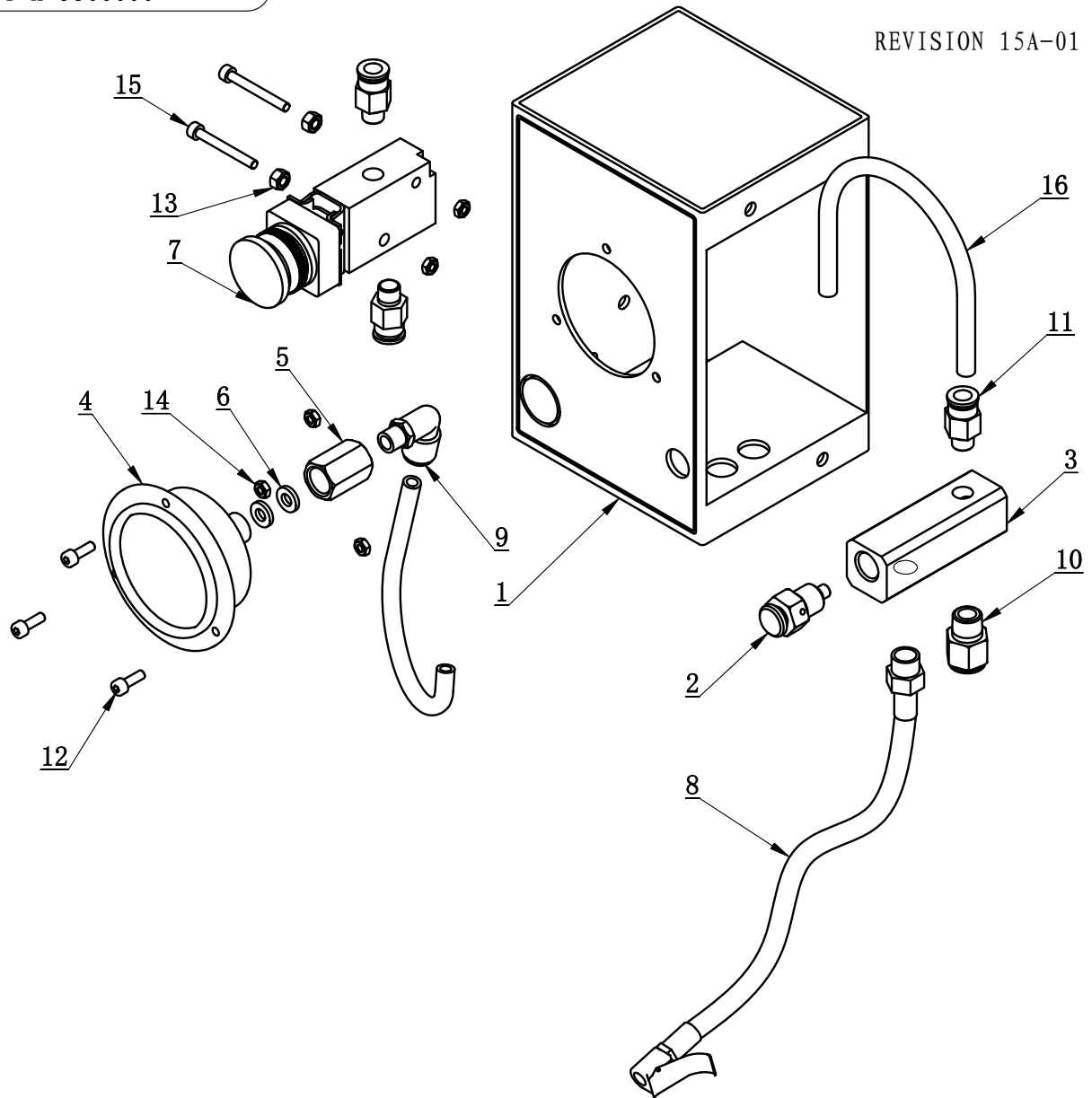

ITEM	PART. No	DESCRIPTION.	QT. Y
1	CT-K-3100001	PRESSURE GAUGE COVER	1
2	CT-K-3110000	EXHAUST VALVE ASSEMBLY	1
3	CT-K-3120000	AIR DISTRIBUTING VALVE	1
4	CT-K-3100004	PRESSURE GAUGE	1
5	CT-K-3100002	CONNECT NUT	1
6	TC-10-1620003	AIR REGULATOR WASHER	2
7	JEL-MSV22-06PB	VALVA	1
8	CT-K-3100003	INFLATING HOSE	1
9	FPL 8-01	INSERT ELBOW $\Phi 8$, R1/8	1
10	FPC 8-02	MALE STRAIGHT	1
11	FPC 8-01	MALE STRAIGHT	3
12	GB70. 1-M4 \times 12	INNER HEXA CYLINDRICAL SCREW	3
13	GB6170-M5	HEXANGULAR NUT 1-TYPE	2
14	GB6170-M4	HEXANGULAR NUT 1-TYPE	5
15	GB70. 1-M4 \times 35	INNER HEXA CYLINDRICAL SCREW	2
16	PU-0800240-Y	PU HOSE $\Phi 8 \times 5$	2

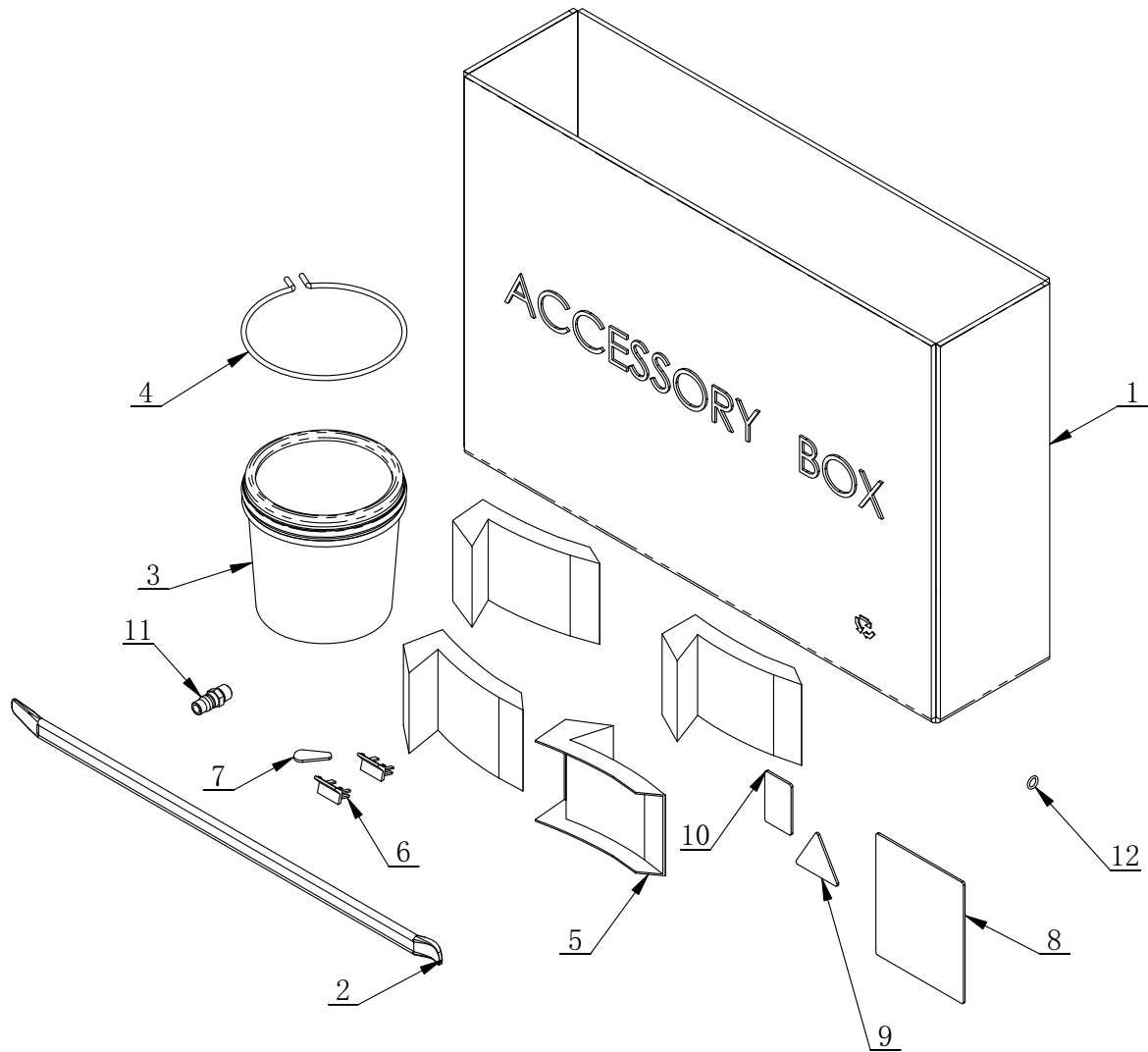

ITEM	PART. No	DESCRIPTION.	QT. Y
1	C-54-8000002	ACCESSORY BOX	1
2	C-54-8000003	20INCH CROWBAR	1
3	C-54-8100000	GREASE CONTAINER	1
4	C-54-8000004	BRACKET	1
5	C-54-8000005	CLAMP PROTECTION COVER	4
6	C-54-8000006	SHEATH	2
7	C-54-8000007	PLASTIC COVER	1
8	C-54-8000008	USER MANUAL	1
9	C-54-8000009	PASS CARD	1
10	C-54-8000010	GUARANTEE	1
11	C-54-8000011	AIR SUPPLY CONNECTOR	1
12	GB / T 3452.1-2005 8x2.65	HYDRAULIC-PNEUMATIC RUBBER O-RING G TYPE	1