

REVISION A-01

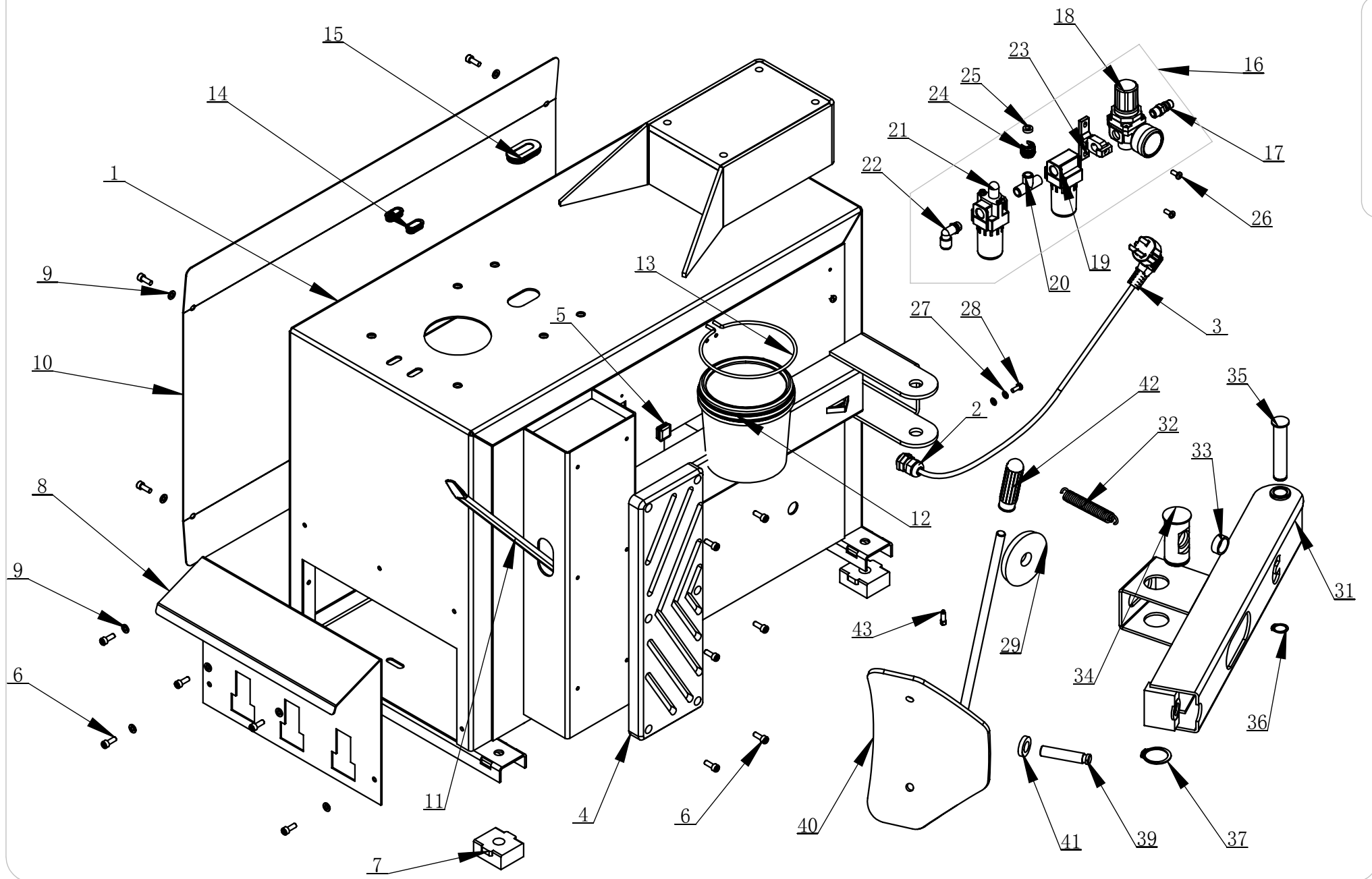

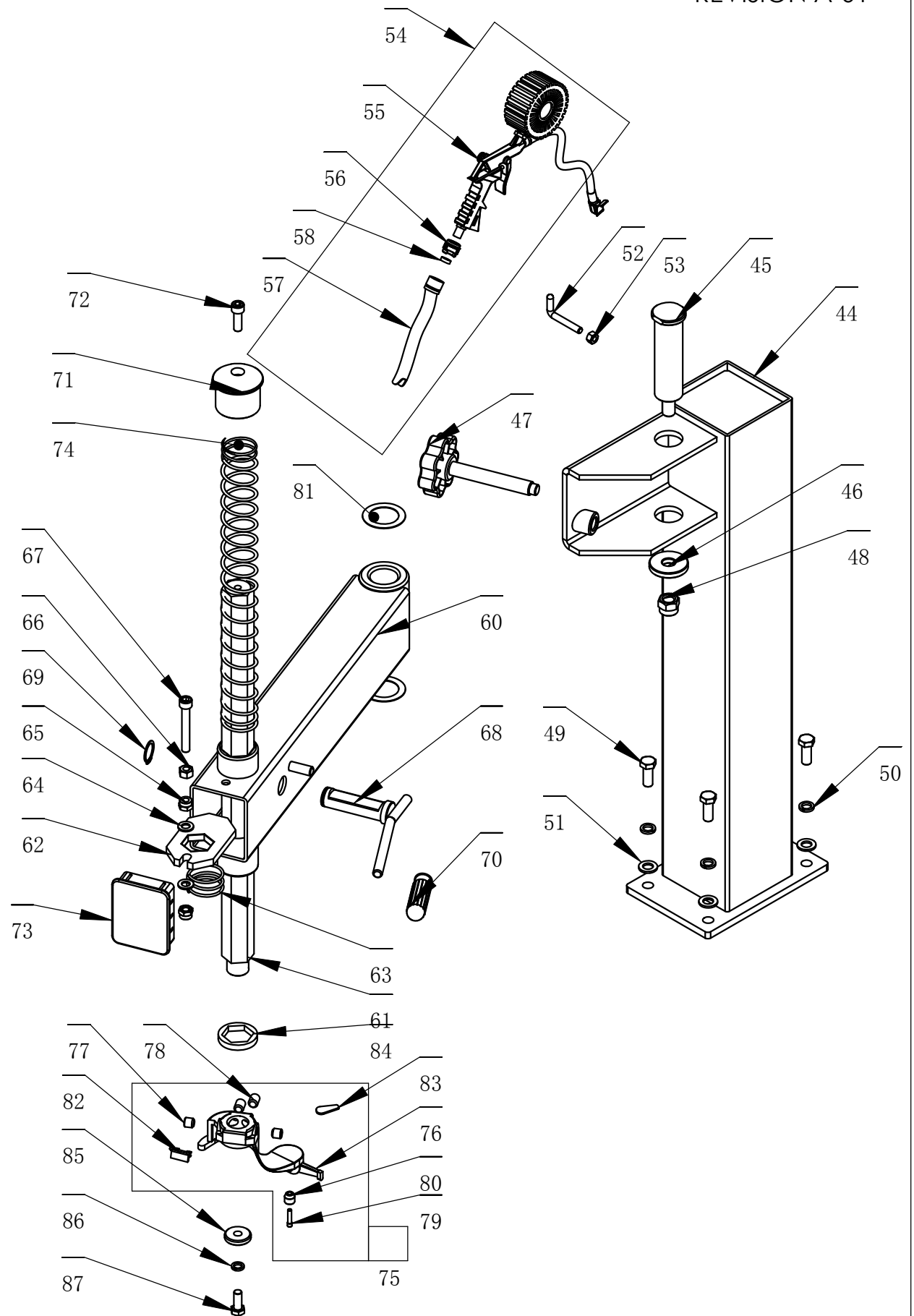

88

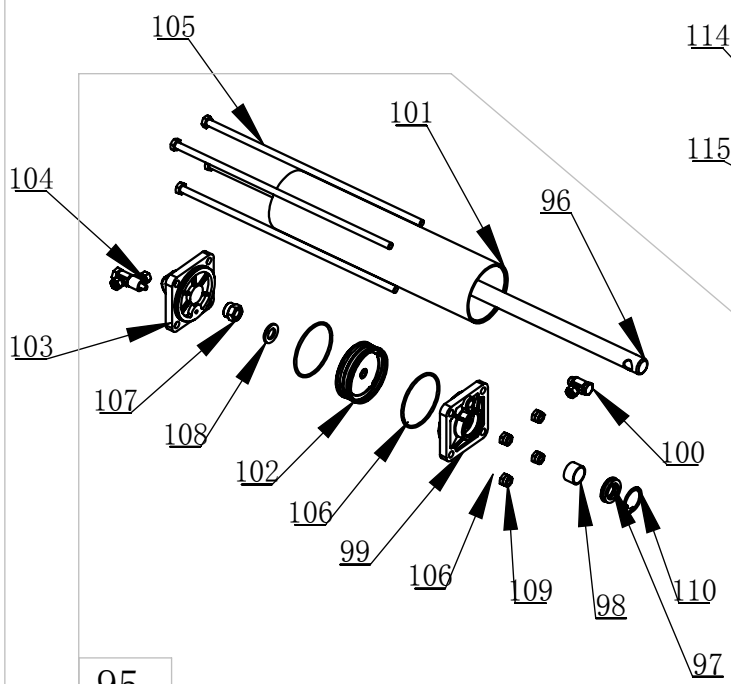

95

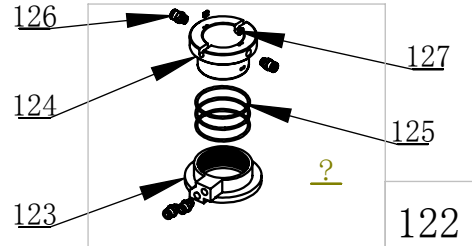
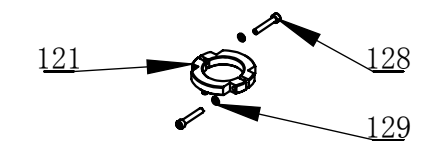
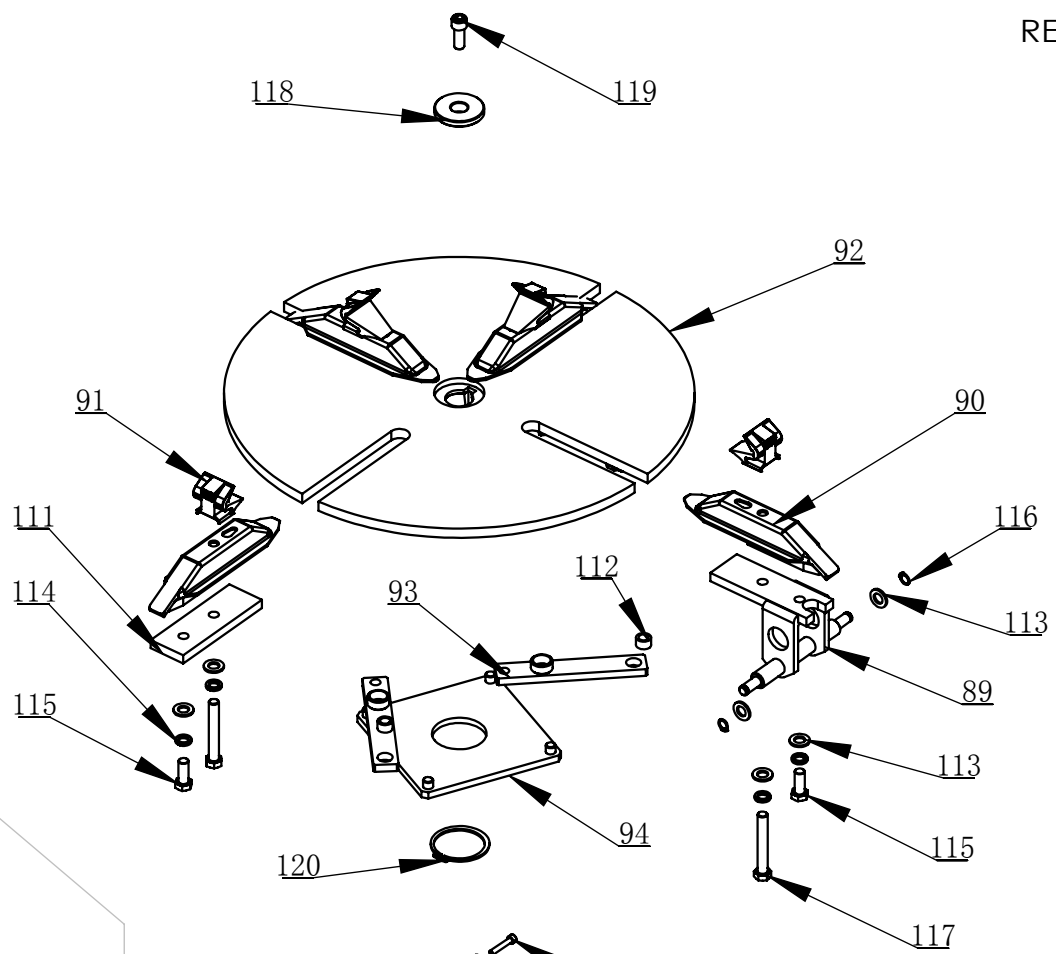

122

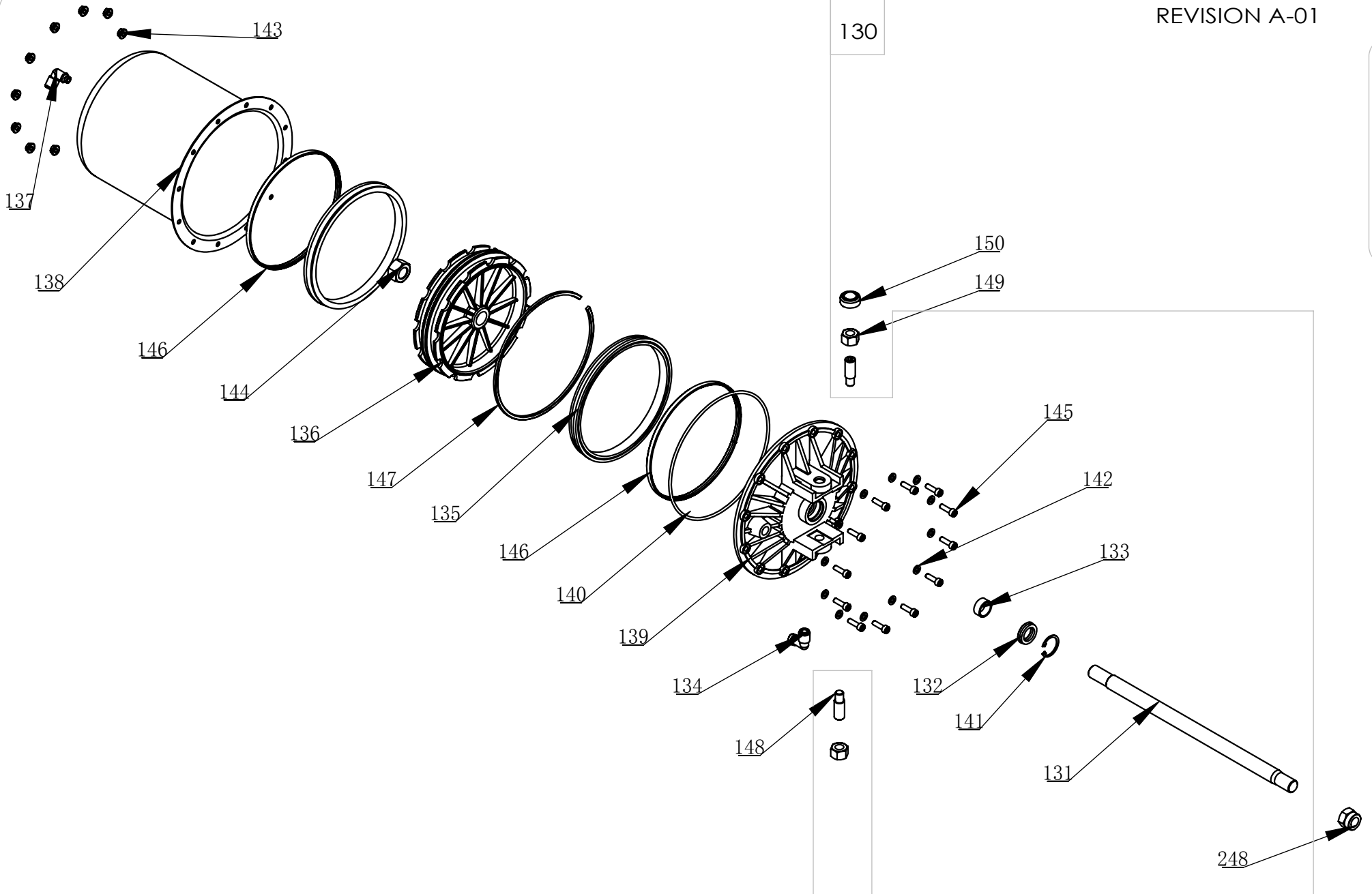

REVISION A-01

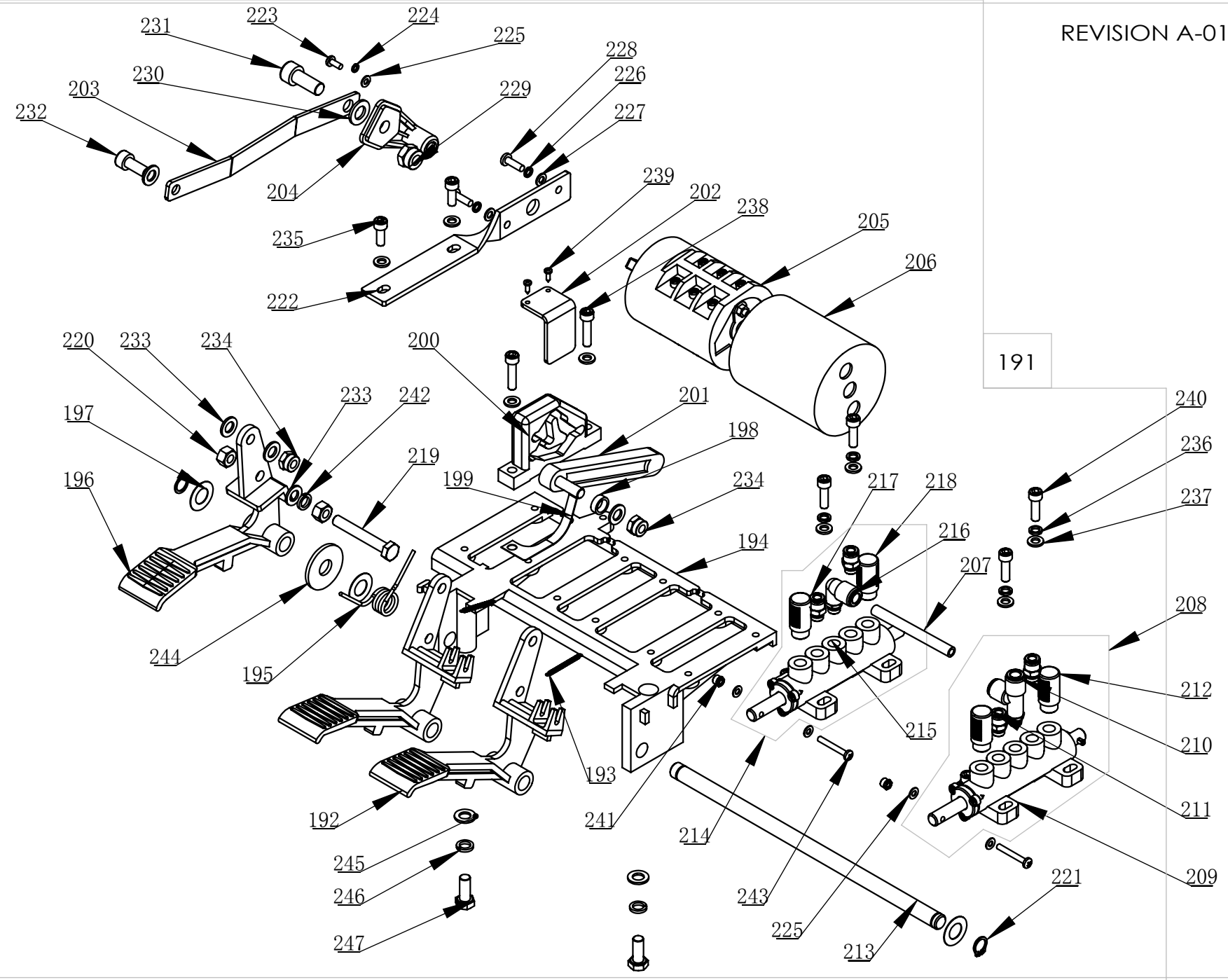

ITEM	PART No	DESCRIPTION.	QTY
1	6009218	BODY	1
2	5502049	CABLE CONNECTOR	1
3	5509113	POWER CABLE ASSEMBLY	1
4	6009162	RIM SUPPORT	1
5	5502046	STOP-UP	1
6	5009015	SCREW M6X16	15
7	5502045	RUBBER FOOT	4
8	6004531	PROTECTIVE COVER	1
9	5008063	WASHER 6	9
10	6004530	SIDE PANEL	1
11	5004094	CROWBAR 20 "	1
12	5509141	GREASE CONTAINER	1
13	5004092	BRACKET	1
14	5509153	PLUG A	2
15	5509155	PLUG B	1
16	5509284	AIR REGULATOR ASSEMBLY	1
17	5004079	AIR SUPPLY CONNECTOR	1
18	5509149	ADJUSTING VALVE	1
19	5004086	WATER CUP	1
20	5004082	TEE R1/4	1
21	5004087	OIL CUP	1
22	5004083	INSERT ELBOW $\Phi 8$, R1/4"	1
23	5004085	BRACKET	1
24	5004075	OPEN NUT	1
25	6000266	RING D13XD7X4	1
26	5006007	SCREW M5X12	4
27	5010045	WASHER 5	2
28	5009093	BOLT M5X12	1
29	5004073	RUBBER PLATE	1
30	6000358	BEAD BREAKING ARM ASSEMBLY	1
31	6000359	BEAD BREAKING ARM ASSEMBLY	1
32	6000360	SPRING	1
33	6000344	SLIDE SPACER	1
34	6000361	BEAD BREAKING ARM SLIDE	1
35	5506001	BEAD BREAKING ARM BACK PIN	1
36	5009117	CIRCLIP 18	1
37	5010116	CIRCLIP 34	1
38	6000012	SHOE ASSEMBLY WELDING	1
39	6000759	ROTATION SPINDLE	1
40	6009163	BEAD BREAKER BLADE	1
41	5010091	WASHER 14	1
42	6008091	RUBBER COVER	1
43	5010110	SCREW M6X16	1
44	6004532	VERTICAL COLUMN	1
45	6005014	ROCKER VERTICAL SHAFT	1
46	6010036	SHAFT WASHER	1
47	5502048	HANDLE WHEEL	1

ITEM	PART No	DESCRIPTION.	QTY
48	5004215	NUT M16	1
49	5006041	BOLT M12X30	4
50	5010025	WASHER 12	4
51	5010020	WASHER 12	4
52	6010039	INFLATING GUN HOOK	1
53	5002060	NUT M8	1
54	5509174	INFLATING GUN ASSY	1
55	5004098	INFLATING GUN	1
56	5004075	OPEN NUT	1
57	5502124	INFLATION HOSE	1
58	6000266	RING D13XD7X4	1
59	6005020	SWING ARM	1
60	6005016	SWING ARM	1
61	6005017	HEXAGON SHAFT	1
62	5502053	HEXAGON LOCK PLATE	1
63	5502052	VERTICAL SHAFT SPRING	1
64	5509151	WASHER 10	2
65	5080112	NUT M10	2
66	5010004	NUT M10	1
67	5000034	SCREW M10X70	1
68	6010042	LOCK HANDLE	1
69	5002030	CIRCLIP 25	1
70	6008091	RUBBER COVER	1
71	5004200	VERTICAL SHAFT COVER	1
72	5000033	SCREW M10X30	1
73	6005018	DECORATING COVER	1
74	6005011	VERTICAL SHAFT SPRING	1
75	5509220	DEMOUNTING HEAD ASSEMBLY	1
76	5502123	DEMOUNTING HEAD	1
77	5004021	SCREW M12X12	2
78	5004023	SCREW M12X16	2
79	5004116	ROLLER BOLT	1
80	5004117	ROLLER	1
81	6005027	ADJUSTING WASHER	2
82	5509015	SHEATH	1
83	5509014	PLASTIC COVER	1
84	5004115	SHOCK ABSORBER WASHER	1
85	5004201	PRESS WASHER	1
86	5010006	WASHER 10	1
87	5009146	BOLT M10X25	1
88	6009213	TURNTABLE ASSEMBLY	1
89	6000103	CYLINDER BRACKET	2
90	6000101	SLIDE COVER	4
91	6000107	CLAMP	4
92	6000102	TURNTABLE	1
93	6000104	CONNECTION PLATE	4
94	6000105	SQUARE TURNTABLE	1

ITEM	PART No	DESCRIPTION.	QTY
95	6000087	CYLINDER ASSEMBLY	2
96	6000006	SHAFT-CYLNDR	1
97	6000007	SEAL-ROD, CYLNDR	1
98	6000008	BEARING-SLIDE	1
99	6000004	FRONT COVER	1
100	6000009	HINGE ELBOW $\Phi 6$ R1/8"	1
101	6000002	SLEEVE-CYLNDR 70	1
102	6009143	PISTON-W/WSHR, ASSY	1
103	6000003	REAR COVER	1
104	6000010	HINGE TEE $\Phi 6$ R1/8"	1
105	6000005	BOLT	4
106	5010021	O RING 65X2.65	2
107	5010022	NUT M12	1
108	5010020	WASHER 12	1
109	5010092	NUT M8	4
110	5010105	CIRCLIP 30	1
111	6000108	PRESS PLATE	2
112	6000109	SPACER	4
113	5010020	WASHER 12	12
114	5010025	WASHER 12	8
115	5006041	BOLT M12X30	4
116	5004015	RING 12	4
117	5009128	BOLT M12X83	4
118	6000106	PRESS COVER	1
119	5002054	SCREW M12X30	1
120	5010030	CIRCLIP 65	1
121	6000618	CLAMP RING	1
122	6000619	ROTATING UNION	1
123	6000724	AIR GUIDE EXTERNAL COVER	1
124	6000725	AIR GUIDE ROTATION BUSHING	1
125	5010231	RING 60X2.65	3
126	5010060	INSERT FITTING $\Phi 6$, R1/8"	4
127	5002078	SCREW M3X6	4
128	5004031	SCREW M6X35	2
129	5010058	WASHER 6	2
130	6009247	BEAD BREAKER CYLINDER ASSEMBLY	1
131	6000027	CYLINDER PISTON ROD	1
132	6000007	SEAL-ROD, CYLNDR	1
133	5010204	GUIDER SPACER	1
134	5004083	INSERT ELBOW $\Phi 8$, R1/4"	1
135	5509160	Y-RING	2
136	6000279	PISTON	1
137	5509158	INSERT ELBOW $\Phi 8$, R1/8"	1
138	6000280	CYLINDER BODY	1
139	6000299	CYLINDER COVER	1
140	5010097	O-RING 185x3.55	1
141	5010105	CIRCLIP 30	1

ITEM	PART No	DESCRIPTION.	QTY
142	5008063	WASHER 6	12
143	5010042	NUT M6	12
144	5010114	NUT M18X1.5	1
145	5004032	SCREW M6X20	12
146	5509161	CLAMP RING	2
147	5509162	PISTION SUPPORT RING	1
148	5010205	SCREWS M14X42	2
149	5000086	NUT M14	2
150	5004070	SEALED COVER	1
151	6000351	GEARBOX ASSEMBLY	1
152	5004060	SCREW M8X30	5
153	6000353	GEARBOX TOP	1
154	5004208	PIN 8X20	2
155	5010078	SCREW M16X1.5X15	1
156	5010002	ROLLING BEARING 6010	1
157	6000352	WORM SHAFT	1
158	5009082	PLAIN KEY 12X56	1
159	6000354	WORM	1
160	5010001	CIRCLIP 50	1
161	6000355	CAP 40X25X8	1
162	5000015	ROLLING BEARING 30205	2
163	6000356	GEARBOX BASE	1
164	5002060	NUT M8	5
165	5010077	BOLT M8X20	1
166	5009118	WASHER 8	1
167	5002086	PLAIN KEY 6X9X22	1
168	6000275	BELT PULLEY	1
169	5010208	SEALED RING	1
170	6000273	WORM ROD	1
171	5010076	ROLLING BEARING 6208	1
172	5509151	WASHER 10	14
173	5010004	NUT M10	14
174	5006003	PLAIN KEY 12x45	1
175	6009246	MOTOR ASSEMBLY	1
176	5509285	MOTOR AC380V (220V) 50Hz	1
177	6000183	RUBBER WASHER	8
178	6000182	MOTOR SUPPORT	1
179	6009145	MOTOR BELT PULLEY	1
180	5509151	WASHER 10	4
181	5010004	NUT M10	4
182	5010041	BOLT M10X50	4
183	5004005	WASHER 10	4
184	5010232	SCREW M5X16	1
185	5011008	NUT M5	1
186	5010056	PLAIN KEY 6X36	1
187	5004076	BELT A-25	1
188	5004005	WASHER 10	6

