



microtec 880/870

Wheel balancing computer



Documentation data:

BA-mt880/870/En/Rev.002/05.98
EDV 901 882 002

Patent: US 6.003.367
EP 0728299

First edition: 09.97
Version: mt880/870/En/Rev.002/05.98

Modifications: 05.98
Archive: dokumentation\handbuecher\wuchtmaschinen/mt880/870/englisch.qxd

Beissbarth GmbH Automobil-Servicegeräte
Hanauer Straße 101 80993 München Telefon 089/14901-0 Telefax 089/14901246

Customer: Street: Postcode/Town: Tel.:	No.	Instructor:
	Sold by:	
	Order issued by:	

 (please check as applicable)

Machine:	
Serial number:	

1. Check on completeness of balancing machine and freedom from damage

 No defects/complaints

Missing parts: _____

Damage in transit: _____

2. Check function of machine

 Clean machine shaft, examine clamping flange Mechanical and electrical functions checked

3. Instruction on handling and operating the balancing machine

 Mechanical construction of balancing machine explained Safety instructions Operation with Action Center Various clamping methods and flanges indicated Various imbalance compensation methods explained Concealed balance weights System adjustments

4. Instruction on special functions of balancing machine

 Operator familiarised with match program Flange calibration explained Visual inspection procedure 60-gram calibration explained

5. Instruction on operating errors

 Special attention drawn to possible wheel clamping errors Reference to fault code table in operating instructions

6. Notes: _____

Customer's signature: _____

Time in flat rate units _____

Name in block letters: _____

Date: _____

The wheels and the running gear (suspension) of an automobile are a major factor in ensuring that it handles and rides well.

Problems can be caused by non-uniform distribution of material in the wheel rim and tyre, possible residual imbalance in the wheel hub, brake drum or brake disc and if the suspension elements are sensitive to damage. The most modern tyre servicing equipment technology is therefore needed.

Beissbarth wheel balancing computers ensure the high measuring accuracy that is essential if wheel imbalance is to be identified and eliminated, and the tyre matched to the wheel rim.

High-quality electronic components and assemblies guarantee these perfect results and the best possible servicing.

Beissbarth wheel balancing computers are another decisive factor that helps to make the modern car dealer's or vehicle repair shop competitive, acceptable to the demanding customer and capable of ongoing development in the future.

Chapter	Item	Page:
1	Technical data	1-1
2	Safety precautions and start-up procedure	2-1
	Setting up the machine	2-1
	Change of machine's location	2-1
	Installing the wheel guard	2-2
	Assembling the monitor	2-2
3	Brief description	3-1
	Control elements, screen buttons and symbols	3-1
4	Preparatory work	4-1
	Clamping the flange	4-1
	Clamping wheel on to flange	4-1
	Description of flanges	4-2
	Checking wheel and tyre	4-7
5	Choice of balancing method	5-1
6	Wheel data input	6-1
	1.) Input with position measuring arm and rim width sensor	6-1
	2.) Input with concealed adhesive weight	6-2
	3.) Manual wheel data input with the Action Center	6-3
7	Balancing procedure	7-1
	Balancing method when using concealed adhesive weights	7-3
	Balancing method with free weight positioning	7-3
8	System settings	8-1
	Suppression and rounding-off inputs for weight display	8-1
	Weight unit	8-1
	Choice of language	8-1
	Date and time settings	8-2
	Selecting dimensions of adhesive and drive-on weights	8-2
	Switching matching suggestion on/off	8-2
9	Special functions (service)	9-1
	Match program	9-1
	Flange calibration	9-2
	Calibration with weight	9-2
	Visual check	9-3
	Version display	9-3
	Service diagnosis	9-3
10	Maintenance and upkeep instructions	10-1
11	Fault code displays	11-1
A	Appendix	
	Mains connection chart	A-1
	Motor connection chart	A-2
	Frequency converter connection chart	A-3
	Declaration of conformity	A-5

Operating range:

Wheel weight:	up to 65kg
Wheel diameter:	Passenger cars from 10" to 20" Light commercials up to 17.5"
Rim width:	up to 13.5" (345mm), motorcycles from 2"
Max. outer diameter of wheel:	900mm
Operating temperature range:	+5°C to 40°C
Atmospheric humidity range:	10-90% at 40°C

Drive:

Motor:	0.37kW 3X100/173V, with power supply from internal frequency converter
Mains voltage	single-phase 200-240V, frequency 50/60Hz
Balancing speed	192 rpm
Measuring time:	2.5 sec
Braking	electric, with additional mechanical brake to lock the wheel before weights are attached
Noise emissions:	LpA value=70 dB (A)

Equipment:

14" VGA colour monitor, resolution 640x480 PC-based computer with CD-ROM drive

Machine dimensions:

With wheel guard (WxHxD) 1350x1540x1650mm

Weight 130kg

Paint finish: enquiry to Beissbarth

The right to modify designs is reserved.

- The wheel balancing machine must only be used to balance vehicle wheels and tyres in conformity with the stated technical data.
- Only properly trained and skilled personnel must operate the machine.
- Power-driven wheel balancing machines must only be operated with a wheel guard in position (German law: please conform with local regulations in other countries).
- Safety equipment must never be removed or put out of action
- Essential repairs must only be performed by servicing personnel familiar with the machine. Any form of tampering with the machine absolves Beissbarth from all liability for resulting damage.
- Before starting work on the electrical system, pull out the mains plug and secure main switch to prevent it from being turned on accidentally.
- Work on the electrical installation must be performed by qualified electrical technicians.
- The wheel balancing machine must not be operated in explosion-risk areas.
- The wheel balancer must only be used indoors.

Warning symbol used



Significance

**Before opening
unplug power
supply**

Setting up the machine

The machine must be secured to a firm, flat and vibration-proof concrete floor, using dowels.

Space required:
microtec 880

Change of machine's location

Please observe the following instructions when transporting the machine to its installation point (or in the event of further changes in location):

- When transporting the machine in its original packing use a suitable fork lift truck which should enter the lower packing pick-up points (pallet).
- Keep transport pallet for future changes of location.
- For machine transport, attach it with suitable wood screws to the pallet.

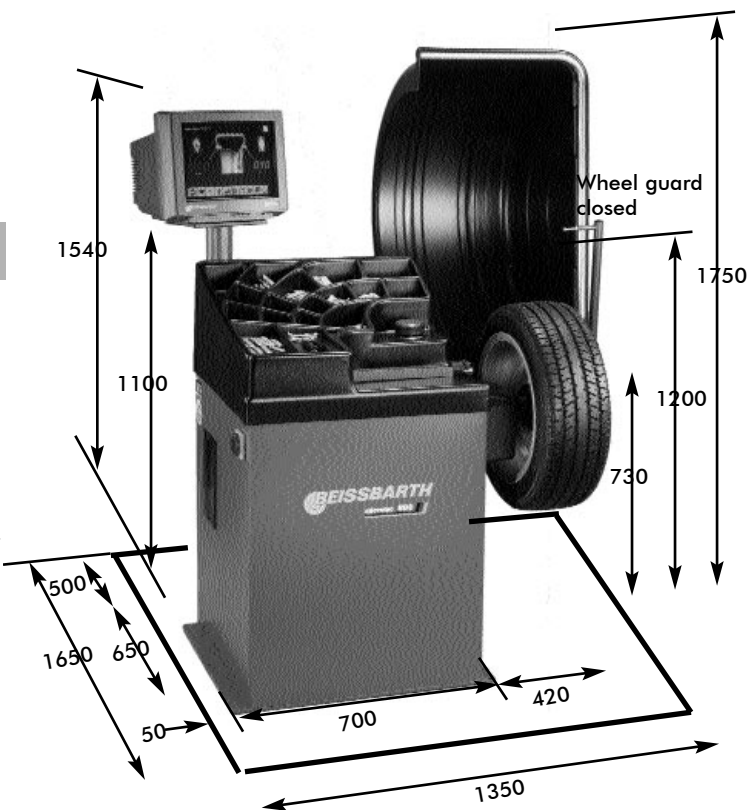



Assembling the wheel guard

Place the tube of the wheel guard on the stub axle of the machine. Insert the two M 8 x 50 retaining screws, attach the washers and nuts (Items 2 and 3) and tighten them.

Study the wiring diagram most carefully before making electrical connections, since if these are incorrect the electronics may be damaged beyond repair. The balancing machine is intended for supply from a 230V (50Hz) AC mains supply.

The wheel being balanced must rotate clockwise.

Before operating the machine for the first time, the balancing flange must be calibrated (see Page 9-2).

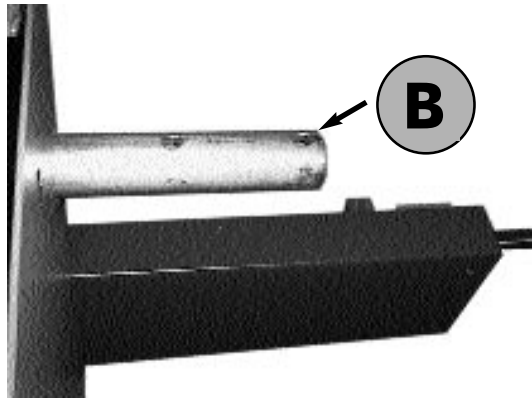

Assembling the monitor

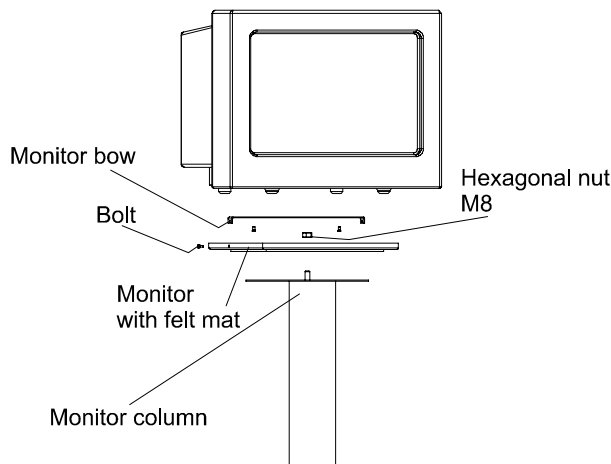

1. Place the monitor tray on the monitor column with the felt mat downwards, and secure with the self-locking M8 hex nut. Do not tighten the nut too far; the tray must turn without applying undue force.
2. Take the monitor carefully out of the packing material and check it for damage in transit.
3. Attach the monitor bracket to the monitor with two self-tapping screws.
4. Place the monitor carefully in position on the monitor tray and secure at the sides with two self-tapping screws.
5. Make the electrical connections to the monitor.

Controls and screen buttons

Action Center:

The Action Center is used to operate all the system functions. It is turned to the left/right to locate the desired function, and pressed to activate it.

**Patent: US 6.003.367
EP 0728299**

Main switch (emergency off):
to switch the machine on and off



Wheel guard:
with electrical interlock (a legal requirement in Germany). Balancing can only take place with the wheel guard closed.

Sensing arm:
to determine rim width (on microtec 880)

Position measuring arm:
to determine rim width and attach adhesive weights

MT 880/870/En/Rev. 002/05/98 * 901.882.002

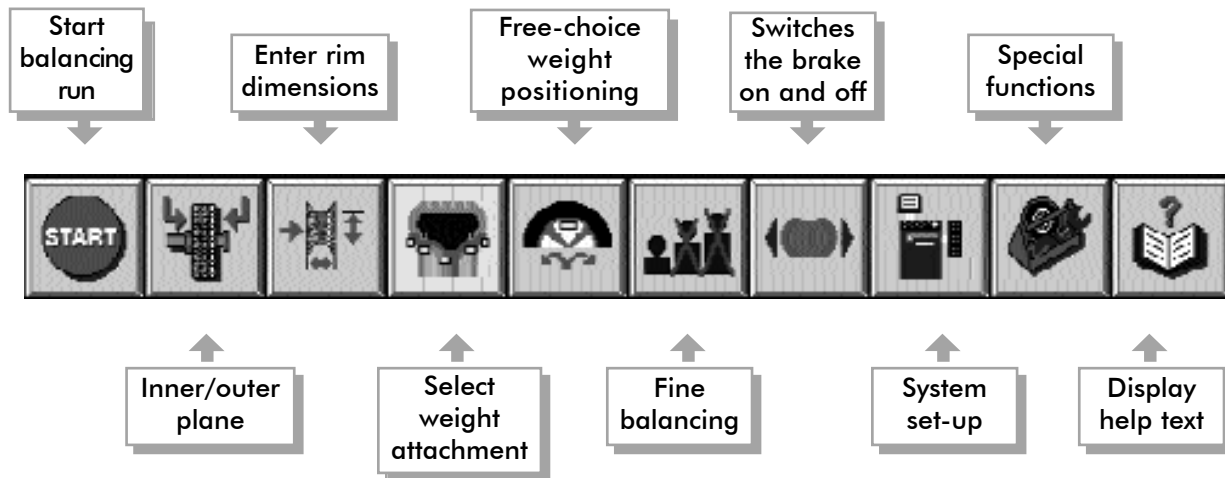

BEISSBARTH MT 870 / MT 880

General-function screen buttons



Display help information

First press the help button, then the key for which help is needed.



Quit screen page

This closes the displayed page on the screen and moves back to the previous page.



Start balancing run

When the balancing procedure has been started, the only screen button remaining operative is the "Stop" button (see below).



Stop

Press this button to halt the balancing run and the visual inspection. The balancing process can also be halted by opening the wheel guard with due care.



Previous page

If the help window is more than one page long, you can use this button to display the previous page.



Next page

If the help window is more than one page long, you can use this button to display the next page.



OK

When the match routine is being run, use the "OK" button to confirm the successive work steps.

Important:

To protect the monitor screen tube, the screen saver is automatically activated.

By activating the Action-Center the last picture shown is displayed again on the screen.



Inner/outer wheel plane

After a balancing operation you can switch between the inner and outer balancing plane with this button.



Enter rim dimensions

This button activates the screen button that is used to select rim distance, rim width and rim diameter and for altering the unit of measurement from millimetres to inches (see also Page 3-4 and Chapter 6).



Select weight attachment

Press this screen button to choose between 8 different methods of balancing (see Page 3-4).



Free-choice weight positioning

Splits the balancing weight proportionally to two freely selectable balancing positions.



Fine balancing

If you have selected a suppression threshold and/or the rounding-off of the imbalance display, pressing this button will show the actual values for a short period.

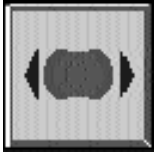

Releases brake briefly



System set-up

Press this button to make various preliminary settings, such unit of weight and date/time (see Page 3-5).



Special functions

This button starts various special functions, e.g. flange and weight calibration (see Page 3-5).

Balancing procedure symbols

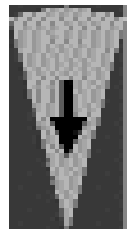

Red adjusting arrow

The shape of the point indicates how far it is to the weight position.

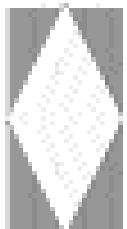
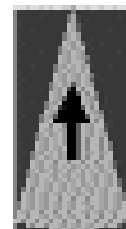

Green adjusting arrow

Lights up when the weight position is reached.

Wheel data settings

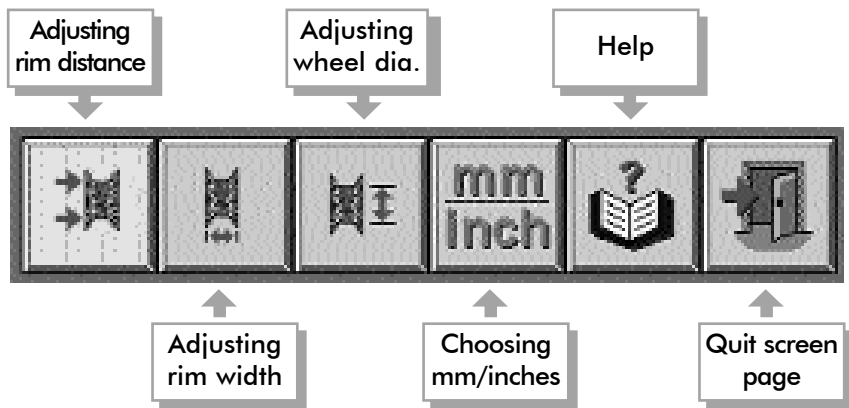

Selecting balancing method

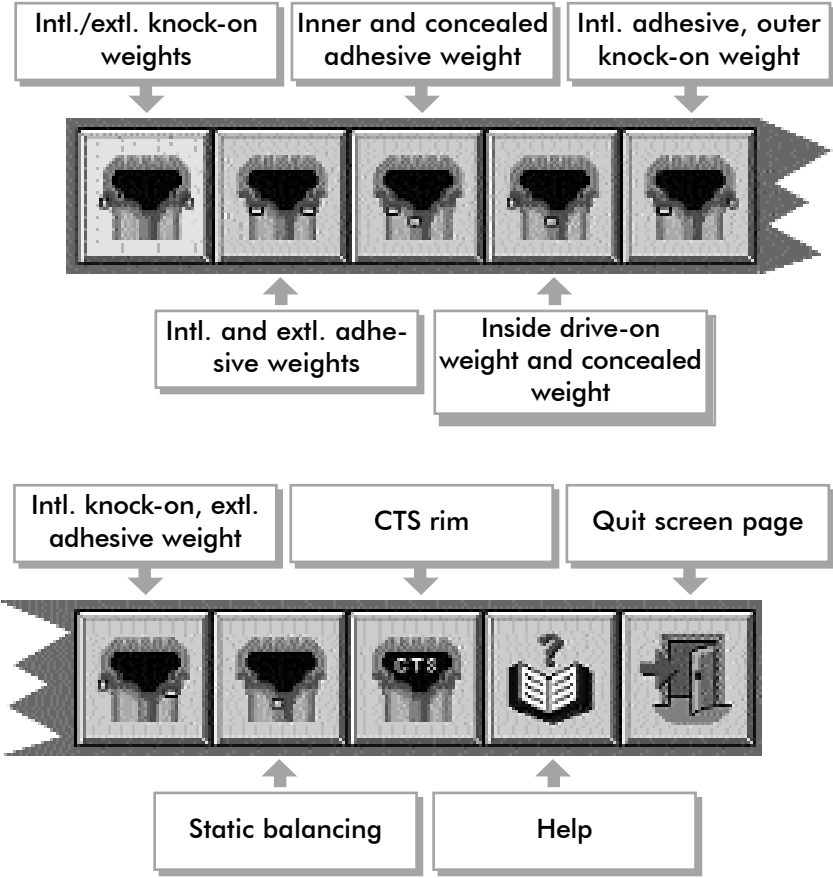

System settings

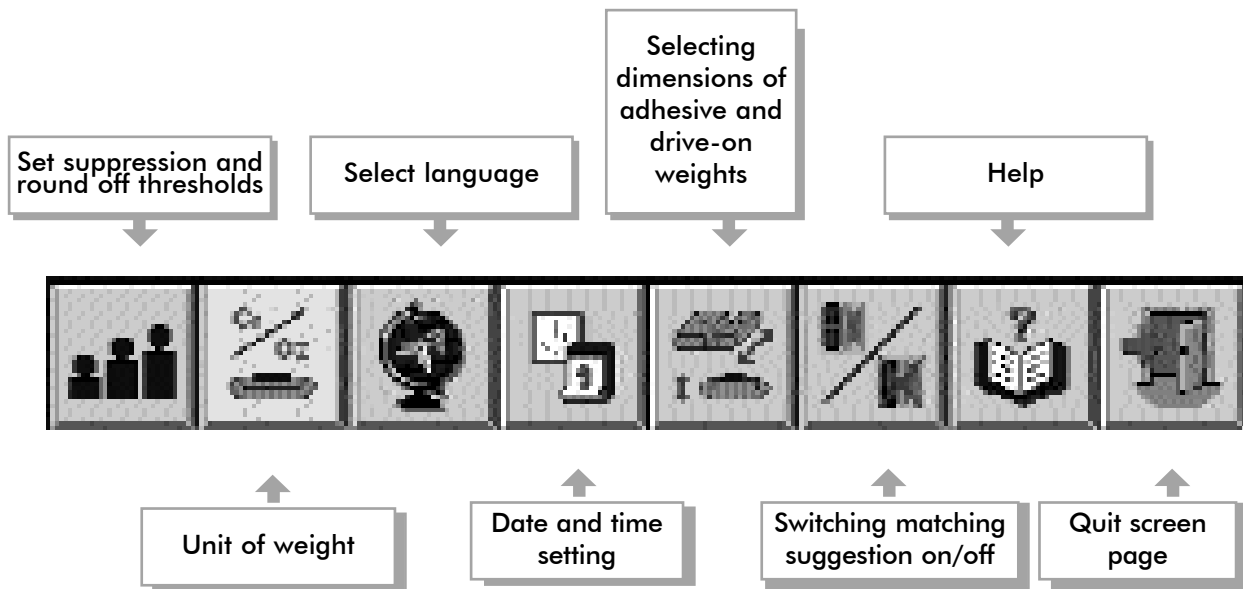

Special functions

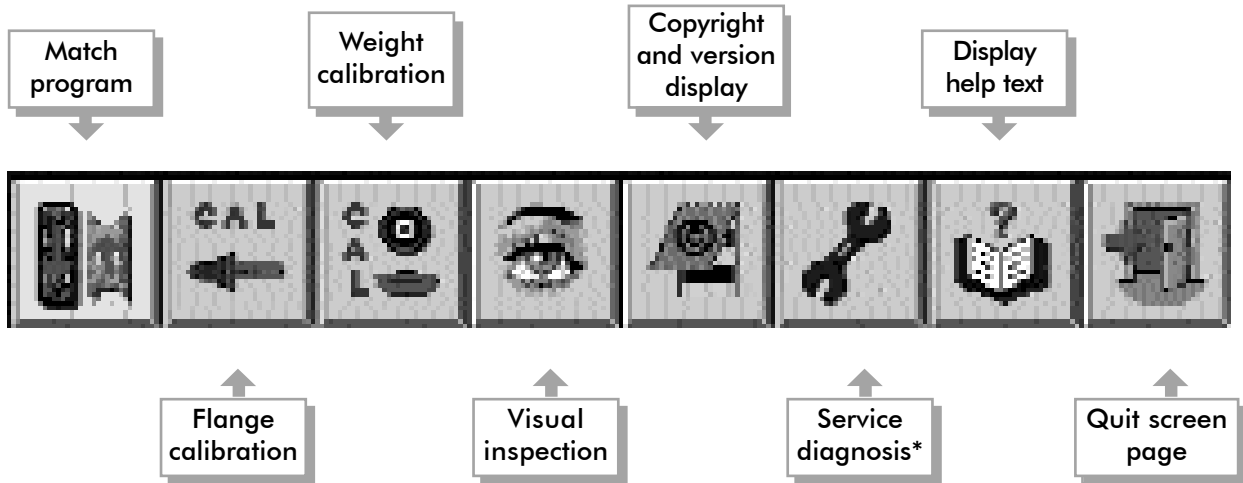

* accessible only to technicians authorised by Beissbarth

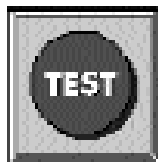

Test

When turning on the main switch, press the test screen button.

The wheel turns slowly (app. 1 sec) and checks all functions.

The start picture then appears on the screen.

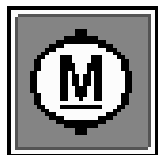

Motor running

This symbol remains on display in the status line (top right) whenever the motor is running.



Error

blinks if an error occurs.

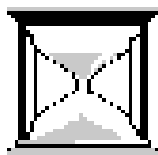

Please wait

While the machine is being started up, an egg-timer symbol is seen at the top right of the screen.



Help mode

blinks when help mode activated.

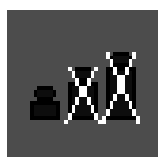

Suppression stage (green)

This symbol is shown when a suppression value of 0 gram/ounces has been selected.

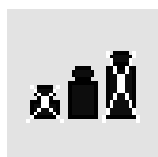

Suppression stage (yellow)

This symbol is shown when a suppression value of 5 grams/25 ounces has been selected.



Suppression stage (red)

This symbol is shown when a suppression value of 10 grams/50 ounces has been selected.

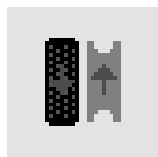

Match mode

This symbol is shown during the matching routine.

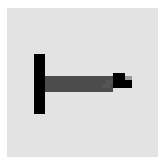

Measuring mode

During the measurement, the position/measuring arm (rim width sensor symbol) is shown.

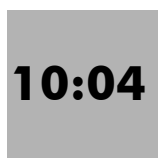

Time display

Permanent display of time in the top left corner of the screen.

Middle-centring flange

For all wheels with a middle hole for centring (about 80% of all wheels), the middle-centring flange is used to clamp the wheel to the balancing machine.

To keep clamping errors as low as possible, always position the wheel with the tyre valve at the bottom when clamping the wheel to the flange or fitting it to the vehicle.

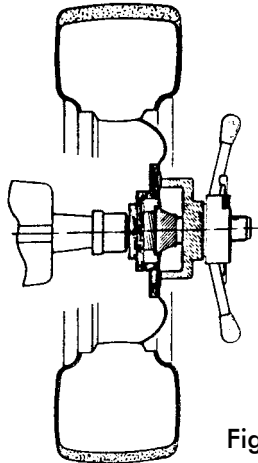

Fig. 1

1. Centring of the wheel with centring cones from the back of the rim, and securing with **clamping cover** and toggle nut from the front:

Push the coil spring over the flange shaft. Select the matching centring cone (the cone must enter the middle-centring hole on the wheel) and push it against the coil spring. Hold the wheel carefully against the centring cone and at the same time press the clamping cover over the flange shaft and against the wheel. Secure the wheel by hand, using the toggle nut. Never use any tools, for instance a hammer.

(See Fig. 1.)

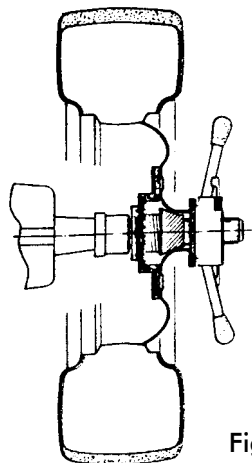

Fig. 2

2. Centring of the wheel with centring cones from the back of the rim, and securing with **pressure ring** and toggle nut from the front:

Centre the wheel as described in Item 1 above. The wheel is secured by a pressure ring instead of the clamping cover. This applies to alloy wheels with a very high dome formed in the wheel, so that the clamping cover does not make good contact, or the wheel pattern is irregular (reinforcing ribs).

(See Fig. 2.)

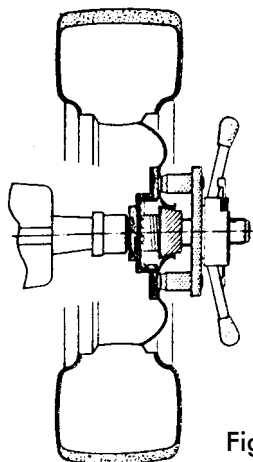

Fig. 3

3. Centring of the wheel with centring cones from the back of the rim, and securing with **centring washers** and toggle nut from the front:

The wheel is centred from the back, as described in Item 1 above. It is secured by a centring disc (types available to suit specific cars) instead of the clamping cover. The centring disc has fixed pins which locate in the corresponding wheel attachment holes and press the wheel against the flange contact face when the toggle nut is tightened.

(See Fig. 3.)

4. Centring of the wheel with centring rings for specific vehicle models from the back of the wheel, and securing with clamping cover and toggle nut from the front of the wheel:

Select the correct centring ring (it must enter the machined centre hole on the wheel exactly) and push it over the flange shaft. Carefully push the centre hole of the wheel over the centring ring and at the same time press the clamping cover over the flange shaft and against the wheel. Tighten the toggle nut by hand to secure the wheel (see Fig. 4). Do not use any tool such as a hammer.

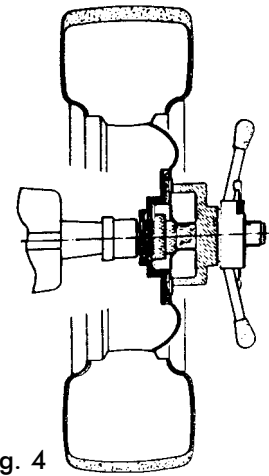

Fig. 4

5. Centring and securing the wheel with centring discs and a quick-clamping ring nut from the front of the wheel:

Motor-vehicle wheels which do not have a machined centre hole can be centred and secured with centring discs supplied for specific models. Hold the wheel against the flange contact face and push the correct centring disc over the flange shaft (with the centring pin leading) into the attachment holes on the wheel. Tighten the toggle nut by hand to secure the wheel (see Fig. 5). Do not use any tool such as a hammer.

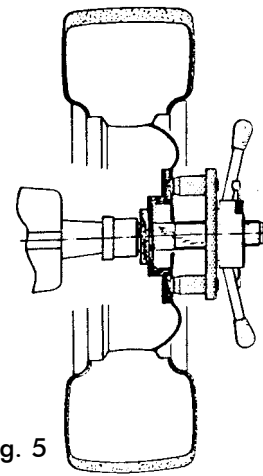

Fig. 5

6. Centring and securing the wheel with centring cones and a toggle nut from the front of the wheel:

This version is seldom needed. It is for wheels with low wall thickness in the machined centre hole area. Hold the wheel against the flange contact face and push a suitable centring cone (which must enter the middle-centring hole on the wheel) over the flange shaft and into the middle-centring hole. Tighten the wheel by hand with the toggle nut (see Fig. 6). Do not use any tool such as a hammer.

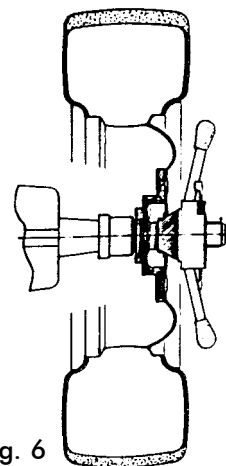

Fig. 6

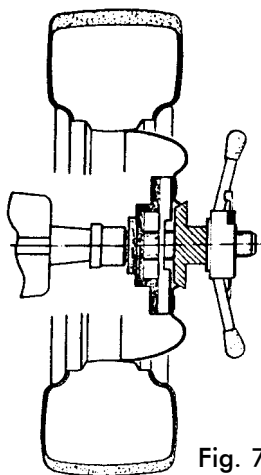

Fig. 7

7. Centring and securing the wheel with centring cones and the toggle nut from the front of the wheel, and a spacing disc from the rear of the wheel for light commercial vehicles:

Since the dish depth of the light commercial vehicle's wheel may be greater, a spacing disc is inserted between the flange contact face and the back of the wheel. Centring and attachment are as described in Item 6 (see Fig. 7).

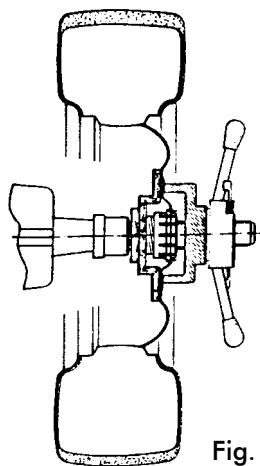

Fig. 8

8. Centring with self-adapting spreader centring sleeves from the back of the wheel, and securing with clamping cover or pressure ring and toggle nut from the front of the wheel:

The optimum method of centring for all wheels with a machined middle centring hole. Push the coil spring over the flange shaft. Assemble the basic sleeve with the correct type of spreader sleeve (depends on the vehicle) and push over the flange shaft; note that the shoulder on the spreader sleeve must be at the front. Carefully push the centre hole of the wheel over the spreader sleeve and at the same time press the clamping cover or the pressure ring over the flange shaft and against the wheel. Tighten the toggle nut by hand against the wheel. Never use any tool such as a hammer.

When clamped, the spreader sleeves eliminate any play. Tolerances between the clamping shaft and the centre hole on the wheel, which is machined cylindrically, are therefore reduced to zero (see Fig. 8).

Special flanges for wheels with no centre hole

For all closed-centre wheels with either 3, 4 or 5 stud holes, and also for all wheels with an unmachined centre hole, UNI flanges are used to clamp the wheels to the balancing machine.

In order to keep clamping errors to a minimum, the tyre valve should always be at the bottom when clamping the wheel to the flange and fitting it to the vehicle. Always tighten the nut nearest to the tyre valve first, then the remaining nuts in a pattern which proceeds across the centre of the wheel to the other side each time. After completion of balancing, fit the wheel to the vehicle by following precisely the same procedure.

9. Centring and securing the wheel with **insert pins and double-cone nuts** or quick-clamping cones.

Select the correct hole pitch circle at the hole centring plate on the flange and insert the required number of pins. Secure the insert pins by tightening the knurled nuts at the rear. Push the wheel's stud holes carefully over the insert pins until it touches the face of the flange. Use a 22 mm box wrench to tighten the double-cone nuts on the insert pins or the quick-clamping cones (see Fig. 9).

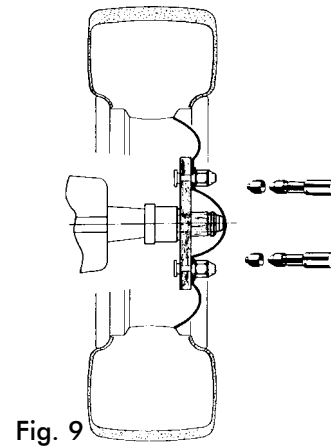

10. Centring and securing the wheel with **sliding pins and double-cone nuts** or quick-clamping cones.

Insert the correct number of sliding pins into the guides on the flange and adjust them to the correct hole pitch circle. The sliding pins are located by ball detents at the selected hole pitch circle. The wheel is attached to the flange as described in Fig. 9 (see Fig. 10).

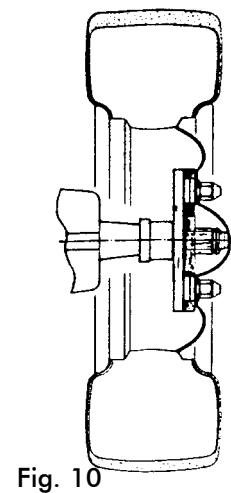

11. Centring and securing the wheel with continuously adjustable **swivel pins and double-cone nuts** or quick-clamping cones:

Unscrew the swivel pins with the T-pattern Allen key and, as necessary, insert the central disc for 3-hole or the combination disc for 4- and 5-hole wheels into the cutout on the flange. Attach the necessary swivel pins loosely at first, according to the numbers stamped on them. To adjust the flange accurately to the desired hole pitch circle, measure the stud holes on the wheel with sliding calipers and transfer the measurement to the swivel pins. Tighten the swivel pins with the Allen key. Attach the wheel to the flange as described in Item 9 (see Fig. 10).

For all motorcycle wheels from 2" rim width with a center hole from 14 mm to 25 mm (with special accessories also for 10 and 12 mm center holes).

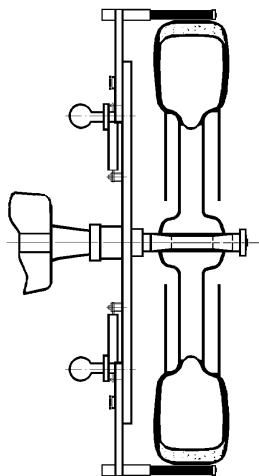

Fig.11

12. Centering the wheel with **centering sleeves or **centering cones** and fastening with knurled nut.**

The two sprung driving pins tighten and drive the wheel from the outside by means of the tread contact surface.

Insert the appropriate centering sleeve into the wheel hub and push it on to the center shaft. Make sure that the wheel does not contact the driving plate but the centering sleeve flange; if necessary, place one of the spacing tubes in between. Place the second centering sleeve over the center shaft into the wheel hub and fasten the wheel with the large knurled nut. For special wheel hubs use the two centering cones instead of the centering sleeves.

(see Fig. 11).

Clean wheels and tyres.

Remove all existing balance weights.

Have suitable balance weights ready.

Check wheel runout (using the accessory dial gauge P 22).



Activate "Special functions" - "Visual inspection" by pressing the Action Center .

The wheel turns at slow speed. When the "Stop" key is pressed, the wheel is held automatically at the position reached.

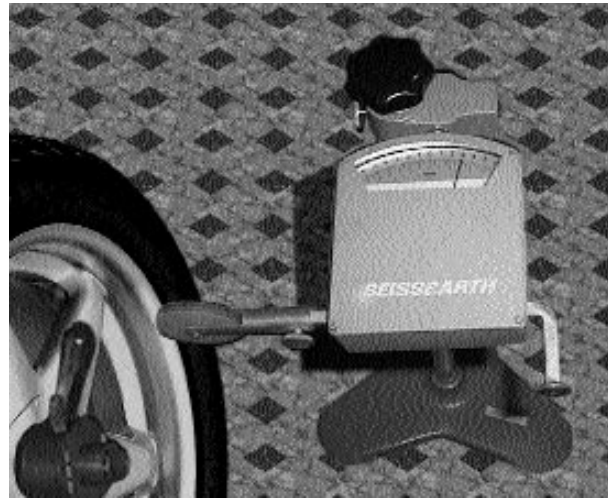



Using the Action Center, mark the screen button "Select balancing method" and press to obtain the screen page for selection of the balancing method.



The screen shows a symbolic wheel. The menu strip contains the screen buttons for the available methods of balancing.



Use the Action Center to mark the desired balancing method on the menu strip (e.g. internal and external adhesive weights) and press to memorise it.

Note:

The selected balancing method remains memorised until a fresh input is made.

The wheel balancing computer automatically determines the precise distance value from wheel rim shoulder to the actual point of attachment for the balance weights.

The chosen balancing method is shown as a symbol on the screen pages.



Note:

There are three different methods of wheel data input:

1.) Input with position measuring arm and rim width sensor

Carefully push the positioning measuring arm away from the zero position against the inner wheel rim shoulder, and wait until the measuring symbol disappears from the wheel rim data adjusting diagram and the rim distance and wheel diameter are displayed.



Carefully move the rim width sensor away from its zero position and push it against the outer rim shoulder. Wait until the measuring symbol disappears and the rim width is displayed in the rim data adjusting diagram.



The wheel balancing computer will then have memorised all three wheel values needed for balancing.

Important:

On the Mt 870 there is no rim-width sensor. The rim width must be input to the computer manually according to version 3 with the aid of the Action-Center

To speed up the measuring procedure, both measuring sensors can be moved against the wheel at the same time.



(Inner drive-on or adhesive weight with one concealed adhesive weight each)

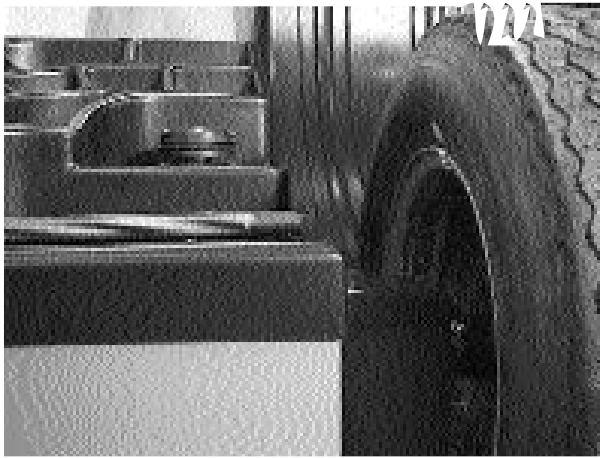

Pull the position measuring arm away from the zero position and into the position on the rim at which the inner drive-on or adhesive weight is to be attached after balancing.

Wait until the measuring symbol disappears and an acoustic signal is heard.

Then move the arm back to the zero position.



Pull the position measuring arm away from the zero position and into the position on the rim at which the concealed adhesive weight is to be attached after balancing.

Wait until the measuring symbol disappears and an acoustic signal is heard.

Note:

To ensure that the position is located reliably, a piece of the adhesive weight can be inserted into the holder on the position measuring arm during the measuring operation.

The wheel balancing computer has then memorised the balance weight attachment points.

Start the balancing process.



3.) Manual wheel data input with the Action Center



Use the Action Center to mark the *"Input wheel data"* screen button, then press to call up the screen page for rim distance adjustment.

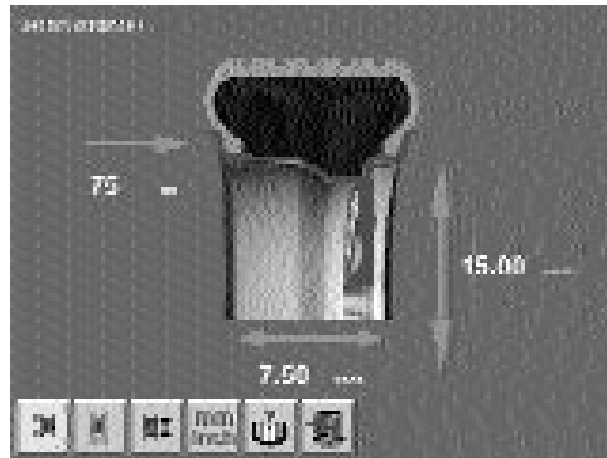

Mark *"Wheel distance - rim width - rim diameter"*



in succession with the Action Center, then press to call up the corresponding function.

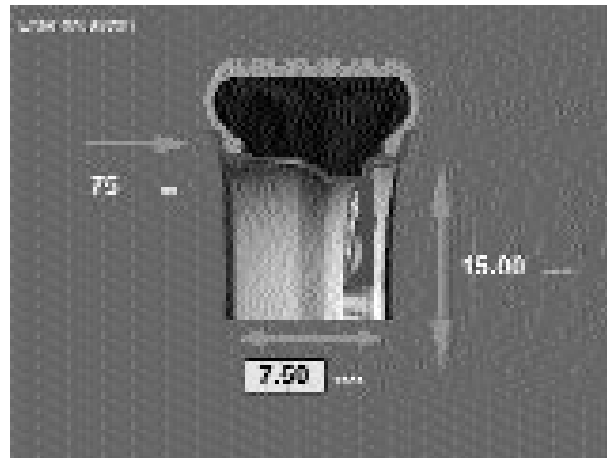

Turn the Action Center:
wheel data are selected.

Press the Action Center:
wheel data are memorised.

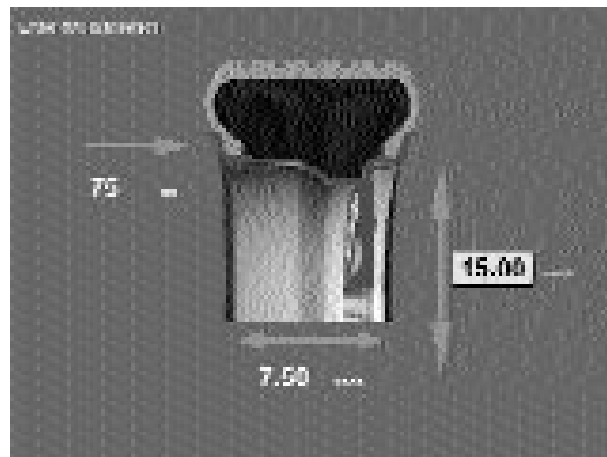

Safety precautions:

In Germany, the wheel guard must be electrically interlocked with the machine. It must not be possible to switch the machine on unless the wheel guard is closed.

(Note: local regulations may differ and should be complied with.)

When the "STOP" screen button is activated, the wheel guard is opened or the main (emergency off) switch is operated, the balancing run is always interrupted.

Close the wheel guard; the machine will start automatically. Alternatively, close the wheel guard, mark the screen button Start balancing run with the Action Center and press to start.



The measuring run lasts approx. 3 seconds, after which the machine brakes the wheel automatically at precisely the external balancing point.

The amount of imbalance and the adjusting arrow for the external wheel plane are shown in green.



Attach the balance weight for the outer plane according to the chosen balancing method.

Note:

The balancing point at which the weight has to be attached for both the external and the internal plane is always in the **12 o'clock** position.

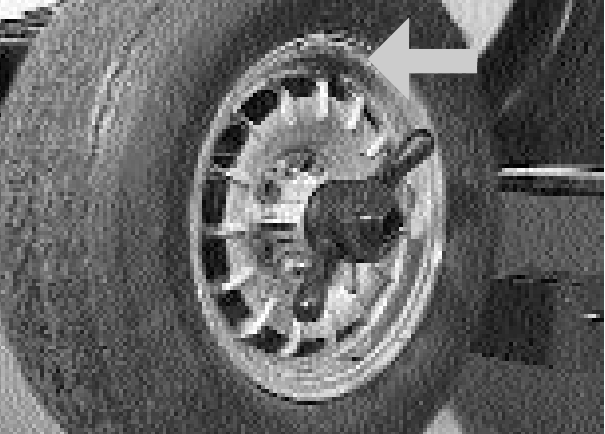



screen button by pressing the Action Center.

The wheel will be turned automatically in the direction for balancing the inner plane.

The imbalance value and adjusting arrow symbol for the inner wheel plane change colour from red to green.

Attach the balance weight for the inner plane according to the chosen balancing method.



A control run can be performed to check the balancing results.



To do this, activate the "Start balancing run" screen button by pressing the Action Center.

If balancing was correct, the digital imbalance values will read "000" in light grey..

Special notes on balancing procedure:



If the suppression and rounding-off input for the weight display was selected during balancing, it can be switched off briefly by activating the "Fine balancing" screen button.



The value is then shown for a short period without suppression or rounding-off.

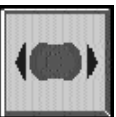

The brake is released for a short time when pressing this screen button (app. 2 s).

Note:

In addition, the brake can also be released for a short time by briefly turning the wheel by hand

- in both directions -



inside adhesive weight
and concealed adhesive
weight



inside drive-on weight
and concealed adhesive
weight

If the balancing method for concealed adhesive weights was activated during balancing, proceed as follows when attaching the adhesive weights:

- Insert the correct adhesive weight in the holder on the end of the position-measuring arm.
- Pull the position measuring arm fully out horizontally (= memorised position for concealed adhesive weight)
- then raise it in this position and press the adhesive weight against the wheel rim. (To make sure that the weight has been attached reliably, press it with your hand.)

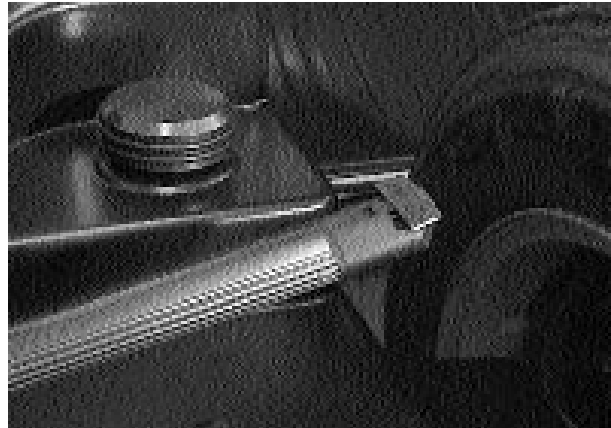

Reset position-measuring arm to start position.

- Press Action-Center :
the wheel automatically turns into the inner plane position . Attach the required adhesive weight to the rim, similar to the concealed adhesive weight or attach inner drive-on weight at 12 o'clock position.

Balancing method with free weight positioning



After the balancing process, mark with the Action-Center the screen key for free weight positioning.





Press Action-Center

Turn by hand to the desired positions of the two (split) balancing weights on the wheel at 12 o'clock.

Note:

To facilitate turning in to the desired weight position, the wheel is slowed slightly for a short time during the procedure.



By pressing the Action-Center the wheel will automatically turn to the first split weight position.

On the screen (=1st balancing plane) the two split gram (weight) displays are indicated in the plane by small figures with the green turn-in arrow.

The relevant 1st split balancing weight is shown in green, the 2nd split balancing weight in red.

Adjust 1st split balancing weight (displayed in green).



Press Action-Center.

The wheel automatically turns to the 2nd split weight position. The corresponding 2nd split balancing weight changes colour from red to green.

Adjust 2nd split balancing weight now displayed in green.



Press Action-Center.

The 2nd balancing plane is then shown on the screen with green turn-in arrow.

Depending on requirements, the standard balancing method or the balancing method with free weight positioning (as described above) can be carried out.



Activate the *“System settings”* screen button by pressing the Action Center.

The screen page with the available settings will appear, with a menu strip.



Weight display suppression and rounding-off

Activate the *“Weight display suppression and rounding-off”* screen button by pressing the Action Center.



Input the desired weight suppression value (0/5/10 grams or 0/25/50 ounces) by turning the Action Center and then pressing it to confirm the input.

Next, activate the rounding-off input (1/5 grams or 0/25 ounces) by a similar procedure to that just described.



Weight unit



Activate the *“Weight unit”* screen button by pressing the Action Center.

Activate the desired unit of weight by turning and then pressing the Action Center.



Selecting language



Activate the *“Select language”* screen button by pressing the Action Center.

Select the local language or the one you wish to use by turning and pressing the Action Center.

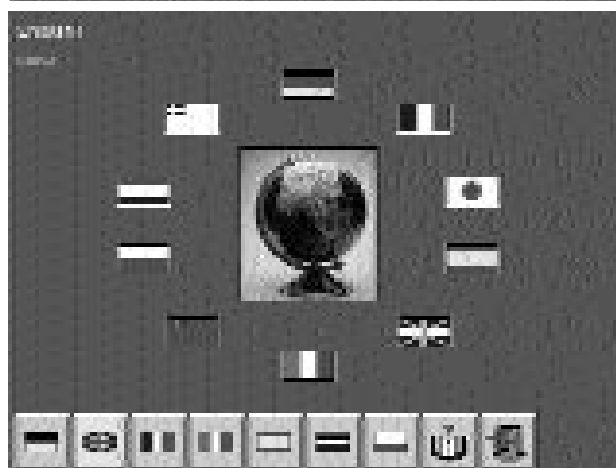



Activate the *“Date and time adjustment”* screen button by pressing the Action Center.

Activate the date display button. Selecting the correct day/month/year by turning the Action Center to the correct position and then pressing it. Adjust the time display in a similar way.

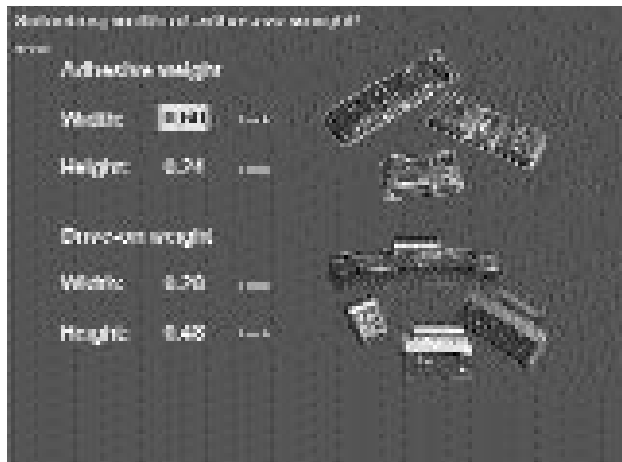

Selecting dimensions of adhesive and drive-on weights

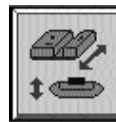

Input width and height of the adhesive or drag-in weights used to the computer. (manufacturer-specific)

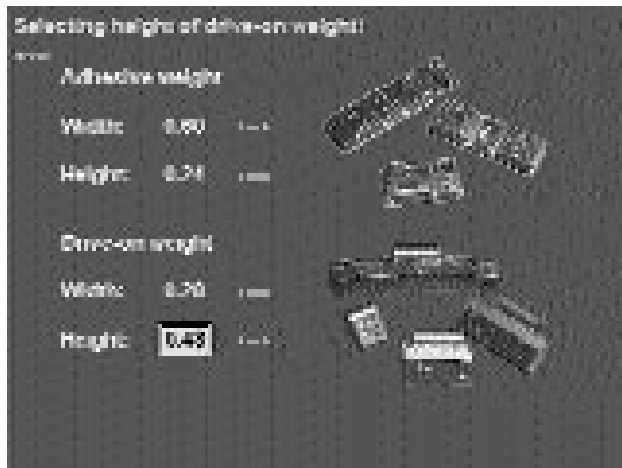

Switching matching suggestion on/off

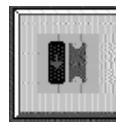

on

off



Activate the *“Special functions”* screen button by pressing the Action Center.

The screen page with special functions will appear, with a menu strip.



Match program

Note:

Above a static wheel imbalance component of 30 grams, matching is recommended in order to compensate for vertical runout and lack of uniformity.



Mark the *“Start matching”* screen button with the Action Center and press it to obtain the screen page:

Matching Step 1.

To ensure accurate matching, always comply exactly with on-screen matching instructions.



To move on to the next matching step, activate the *“OK”* screen button with the Action Center.



Mark the *“Start”* screen button with the Action Center and press to start the matching routine.



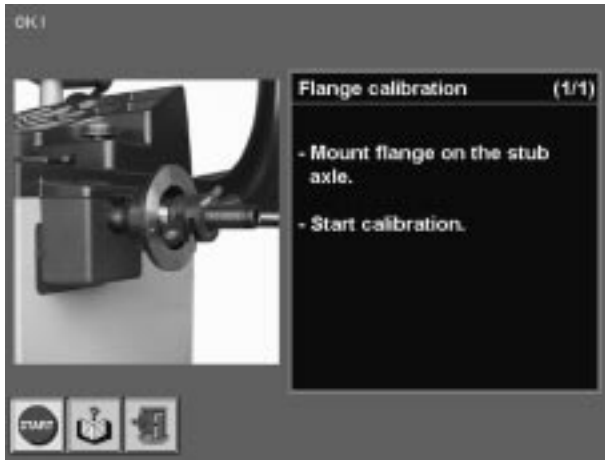

Flange calibration



Activate the "Flange calibration" screen button by pressing the Action Center.

The flange calibration screen page will appear. To ensure reliable calibration, always comply exactly with the screen instructions for the calibration program..

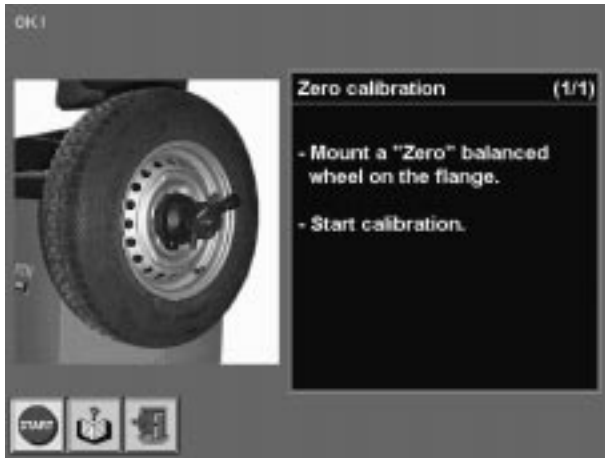

Calibration with weight



Activate the "Calibration with weight" screen button by pressing the Action Center.

The screen page for calibrating with weight will appear. To ensure accurate calibration, always comply exactly with the screen instructions for the calibration program.

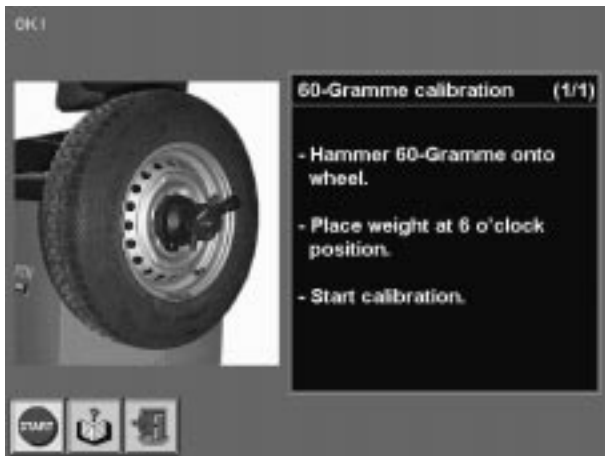

Visual check



Activate the "Visual check" screen button by pressing the Action Center.

The wheel will be turned slowly, and held automatically when the "Stop" button is pressed.



Version display



Activate the "Version display" screen button by pressing the Action Center.

The display shows the manufacturer's copyright, the versions in use, the software status and various equipment modules.



Service diagnosis



The "Service diagnosis" area is only accessible to technicians authorised by the Beissbarth company.

Before carrying out any maintenance or servicing work, disconnect the mains plug from the power supply. If the power supply is permanently attached to the machine, turn off the main switch and secure it in the off position with a padlock so that it cannot be accidentally switched on again.

If malfunctions occur and the machine operator cannot eliminate them, or if fault indications are displayed, please consult Beissbarth's service organisation.

The quality of wheel balancing depends decisively on the condition of the mounting cone at the main shaft, and the corresponding clamping devices. These parts must therefore be looked after with particular care. Keep them clean, dry and free from grease when in use.

If the wheel balancing computer is to remain out of use for a lengthy period, it should be covered over and stored in a dry place. The mounting cone and the clamping devices must be protected against corrosion by coating them with an acid-free oil. However, this oil film must be removed again before the machine is next used.



(+49) 89-14901-233



1. Fault in function sequence

Description:	Possible cause:	Remedial action:
1. No screen image	No power supply	Check mains socket, mains fuses and plug connection to power supply.
	Main (on/off) switch is off.	Turn on the switch at the equipment cabinet.
	Fault in connecting cable.	Renew the connecting cable.
	Monitor is switched off.	Switch on the monitor (switch at bottom right of screen).
	Brightness and contrast settings are too dark for image to be seen.	Adjust brightness and contrast (controls at bottom left of screen).
	Defective cable link.	Check plug connections between monitor and computer; renew cable if necessary.
	CD-ROM has a fault.	Take out and reload the CD-ROM (the drive is at the rear left of the machine).
	Monitor or CD-ROM defective.	Contact Beissbarth Service.
Monitor or Graphic adapter defective	Contact Beissbarth Service.	

2. Faults on screen

1. EEPROM invalid ! The EEPROM has been written with CD Rom default data.	Contact Beissbarth Service
2. The EEPROM ist defective.	Contact Beissbarth Service
3. The self test has found errors in the increment sensor. This is probably defective.	Contact Beissbarth Service
4. The self test has found an error in the drive belts. They are probably damaged.	Contact Beissbarth Service
5. The balancing/calibrating values in the EEPROM are invalid!	The machine must be recalibrated!
6. The arm calibration values in the EEPROM are invalid! All measuring arms must be re-calibrated!	Contact customer service for sensor arm calibration.
7. Self-test has identified incorrect direction of balancing shaft rotation.	Contact Beissbarth Service

processor does not pull the tear line if a fault occurs.

9. The calibrating values are implausible and NOT saved!

The machine must be recalibrated!

Possible causes:

No or wrong weight used (60-grammes clip-on weight required), weight not attached on the outer plane, weight not placed at 6 o'clock position, the unbalance of the wheel is too high for calibrating ("Zero" balanced wheel required!)

10. Status error from the bus processor, balancing processor or Action-Center.

Contact Beissbarth Service

11. Error initiating the EEPROM.

The machine is running with CD Rom default data and cannot be calibrated.

Contact Beissbarth Service.

Check software version of the CD ROM loaded.

12. The balancing processor has detected an internal programme error.

Contact Beissbarth Service

13. The inner sensor arm is incorrectly adjusted and is giving incorrect values.

When switching on the machine, make sure that the inner sensor arm is in the rest position.

Contact our customer service in the event of further errors.

14. The outer sensor arm is incorrectly adjusted and is giving incorrect values.

When switching on the machine, make sure that the outer sensor arm is in the rest position.

Contact our customer service in the event of further errors.

15. Fault reported by frequency converter.

The frequency converter is reset automatically. Any overloading of the frequency converter is eliminated following this report.

If this fault should recur, please switch the machine off and on again.

If the fault persists, consult Customer Service.

16. The motor control is defective.

If the problem persists, switch off and then on again at the mains. If the problem still persists, contact customer service.

17. A problem occurred during the balance cycle.

Please repeat the balance cycle.

If the problem persists, switch off and then on again at the mains. If the problem still persists, contact customer service.

Mains connection chart for mt 880 / mt 870

230 V
50 / 60Hz

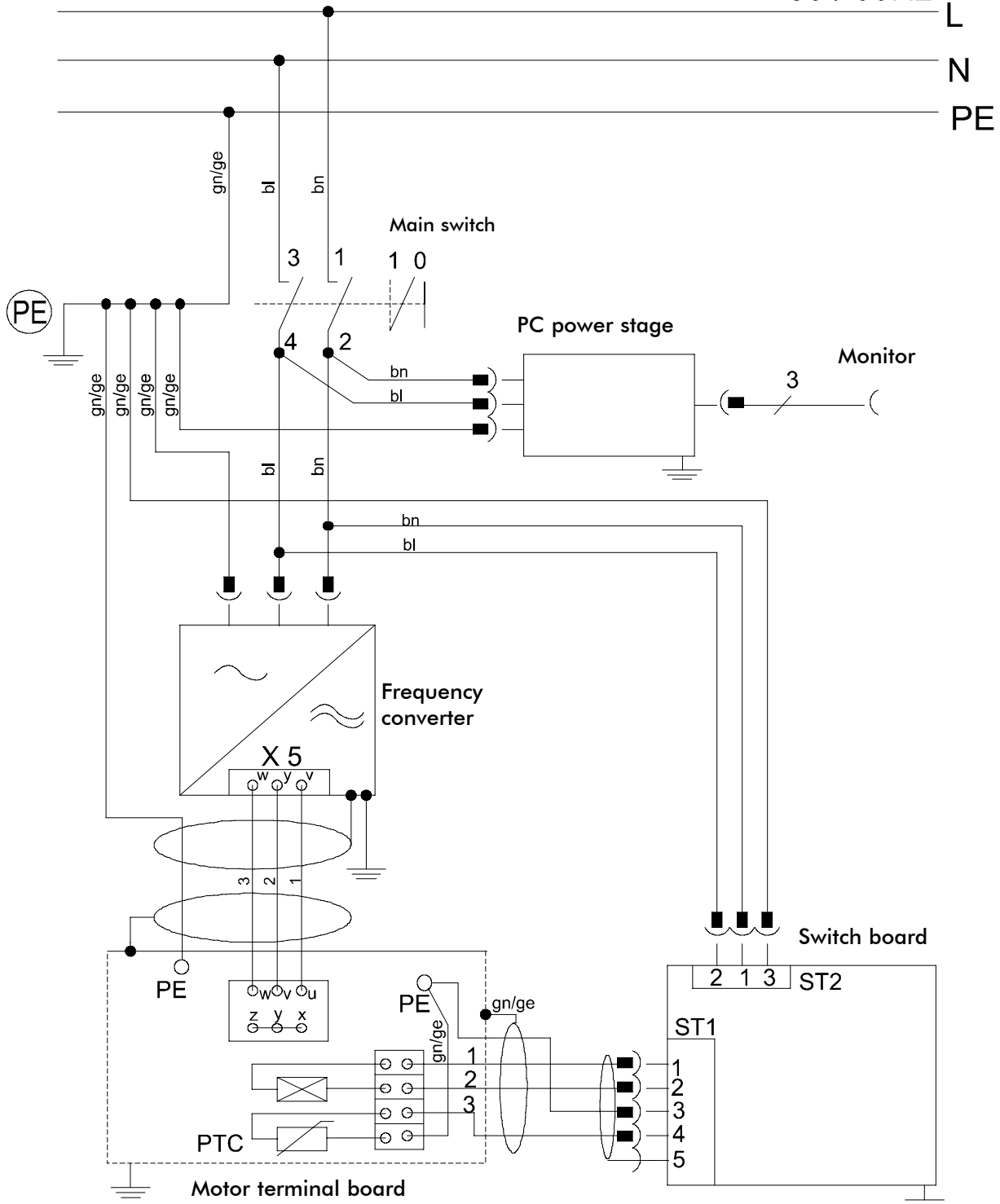

bl - blue
br - brown
gn - green
ge - yellow

MT 880/870/En/Rev. 002/05/98 * 901.882.002

Motor connection chart mt 880 / mt 870

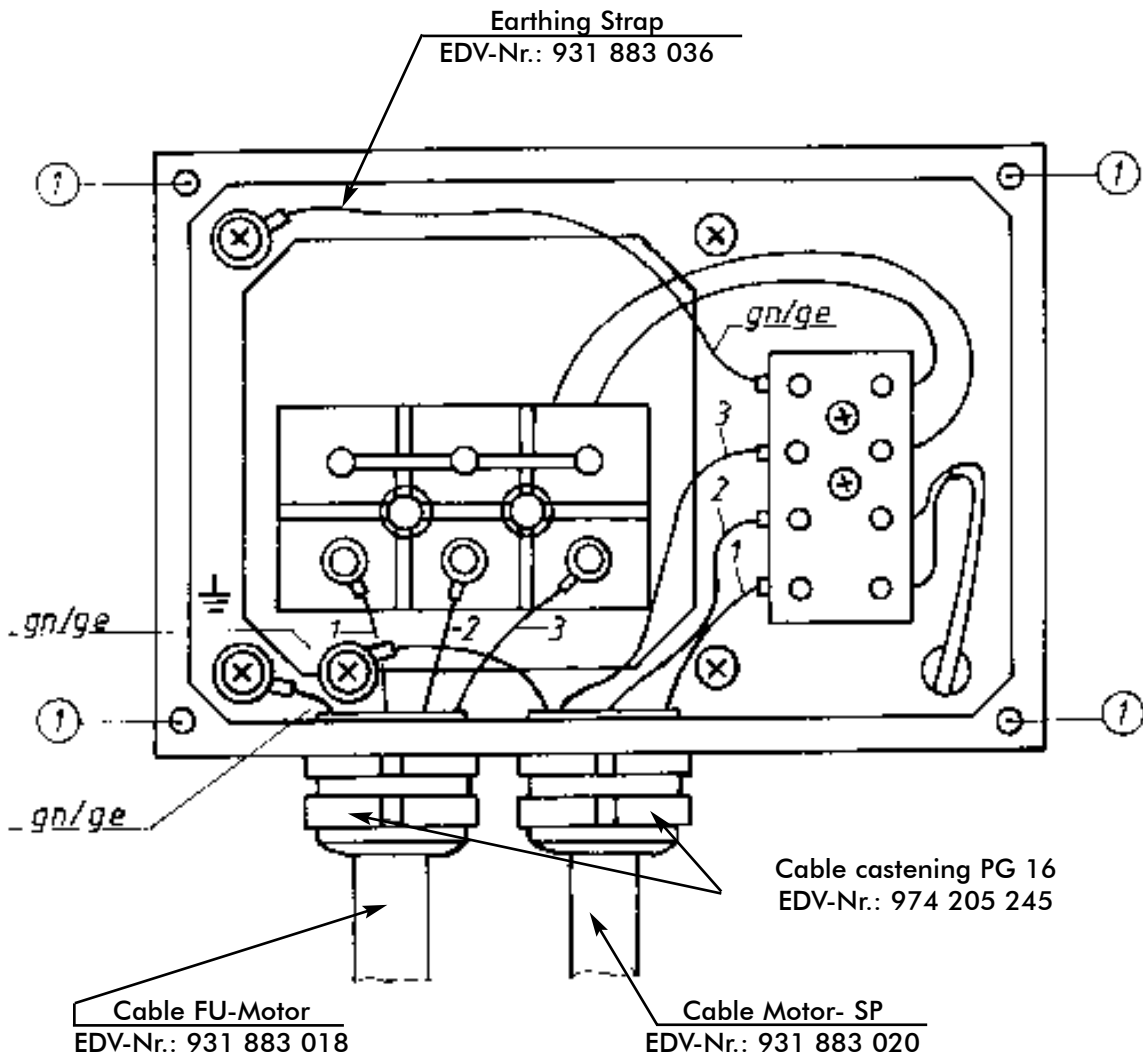

① Lid fixture with washers A 4,3 br - EDV-Nr.: 975 230 007

gn = green
ge = yellow

Frequency converter connection chart mt 880 / mt 870

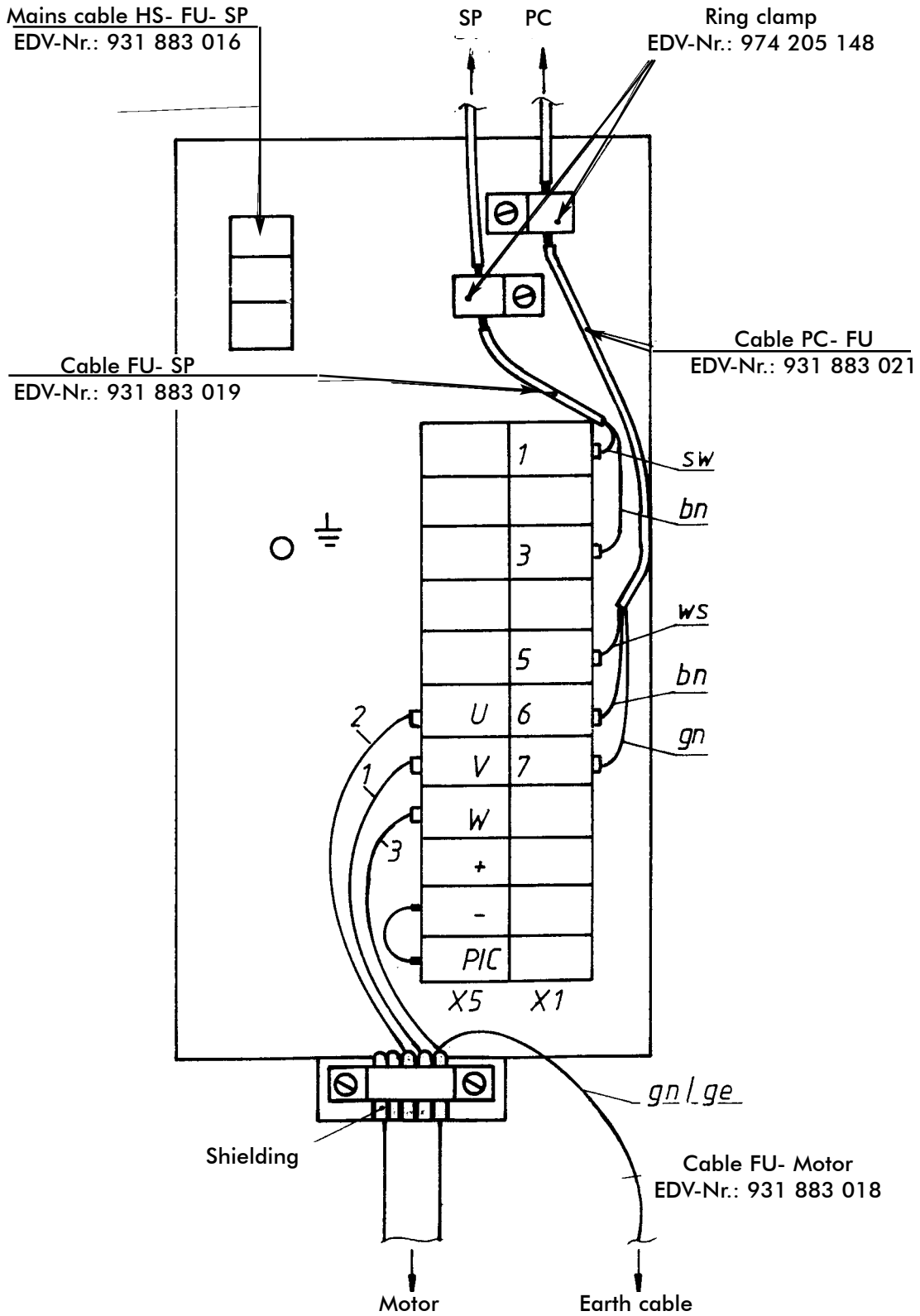

Mt 880/870/En/Rev. 002/05/98 * 901.882.002

BEISSBARTH MT 870 / MT 880

gn = green
ge = yellow

sw = black
bn = brown

ws = white

EG-Konformitätserklärung



**EC-Declaration of Conformity / EC-Declaration de Conformité
CE-Dichiarazione di conformita / CE-Declaracion de conformidad
CE Declaração de conformidade-/ EG Conformiteitsverklaring
EC-försäkran om överensstämmelse**

Hiermit erklären wir, daß die nachfolgend bezeichnete Maschine/Ausrüstung aufgrund Ihrer Konzipierung und Bauart sowie in der von uns in Verkehr gebrachten Ausführung den einschlägigen grundlegenden Sicherheits- und Gesundheitsanforderungen der betreffenden EG-Richtlinie(n) entspricht. Bei einer nicht mit uns abgestimmten Änderung der Maschine/Ausrüstung verliert diese Erklärung ihre Gültigkeit.

We hereby declare, that the following described machine/equipment as a result of its conception and construction in all our distributed versions, meets the relevant fundamental health and safety requirements of the respective EC guidelines. This declaration will lose validity if changes to the machine/equipment are made without our consent.

Nous déclarons par la présente que les machines et équipements décrits ci-après, sont conçus et construits pour l'ensemble de la production, au regard des règles fondamentales du cahier des charges européen. Cette déclaration perd sa validité si des changement sont opérés sur ces machines ou équipement sans notre consentement.

Con la presente dichiariamo che la seguente macchina/attrezzatura e il risultato delola sua concezione e costruzione in tutte le sue versioni distribuite. E conforme ai fondamentall criteri die sicurezza e salute delle rispettive normative CEE. Questa dichiarazione perderà validità se la macchina/attrezzatura subirà modifiche senza il nostro consenso.

Por la presente, declaramos que la máquina/equipo descrito a continuación, como resultado de su concepción y construcción, en todas lasw versiones que distribuimos, cumple con las normas de salud y seguridad descritas en la guía de la CE. Esta declaración perderá validez si se realizan cambios en el equipo/máquina sin nuestro consentimiento.

Pelo presente declaramos que o equipamento/maquina abaixo descrito foi concebido e construido emk todas as versões disponiveis, de acordo com as normas de segurança exigidas da CE. Esta declara çao perderá toda a validade se o equipamento/maquina forem alterados.

Hiermede verklaren wij dat de navolgende machine/apparatuur beantwoordt aan de EG-richtlijnen inzake eisen voor veiligheid en gezondheid zowel op grond van constructie en samenstelling als op grond van de door ons in het gelodigheid indien zonder overleg met ons wijzigingen in de machine/apparatuur worden aangebracht.

Vi härmed intygar att följande maskin/utrustning överensstämmer med var ritning och konstruktion i alla vara distibuerade typer, möter alla de krav pa hälso- och säkerhetskrav i enigt med EC-Riktlinjer. Denna deklaration gäller ej om maskinen/utrustningen ändras utan var vetskap.

Bezeichnung der Maschine/Ausrüstung: Machine/Equipment description: Description de la machine/équipement: Descrizione macchina/attrezzatura: Descripción máquina/equipo: Descrição maquina/equipamento: Aanduiding van de machine/aparatuur:
Maskin/utrustning Beskrivning:

Radauswuchtmaschine / Wheel balancer / Equilibreuse de roues / Equilibratrice / Equilibradora
Equilibradora de rodas / Balanceermachine / Hjulbalancering

Type.: microtec 880 / 870 (mt 880 / 870)

Hersteller-Nr.: Production No.: No. de série: Produzione No.: Producción No.: Número série: Fabrikaatnr.: Tillverkningsnummer:

Fab.Nr./Serial No.:

- **EG Maschinenrichtlinie (89/392/EWG) i.d.F.91/368/EWG,93/44EWG,93/68/EWG73/23/EWG**
- **EG Richtlinie Elektromagnetische-Verträglichkeit (89/336/EWG) i.d.F. 93/68/EWG**
- **EG-Niederspannungsrichtlinie (73/23/EWG) i.d.F. 93/68/EWG**
- **EG-Richtlinie CE Kennzeichnung 93/68/EWG**

In conformance with the requirements of the following EC Guidelines:

- EC-Machine Standard (89/392/EWG)i.d.F.91/368/EWG,93/44EWG,93/68/EWG73/23/EWG
- EC Guidelines for Electro-Magnetic Compatibility (89/336/EWG) - 93/68/EWG
- EC Low VoltageGuidelines (73/23/EWG) - 93/68/EWG
- EC Guidelines for CE Certification 93/68/EWG

En concordance avec les exigences des directives CE:

- **EC-Standard machine (89/392/EWG)i.d.F.91/368/EWG,93/44EWG,93/68/EWG73/23/EWG**
- **Directive CE pour la compatibilit, electro-magnetique (89/336/EWG) - 93/68/EWG**
- **Directive CE pour la basse tension (73/23/EWG) - 93/68/EWG**
- **Directives pour la certification CE 93/68/EWG**

In conformita con le seguenti normative CE:

- CE-Macchina Standard (89/392/EWG)i.d.F.91/368/EWG,93/44EWG,93/68/EWG73/23/EWG
- Normativa ce per compatibilita elettromagnetica (89/336/EWG) - 93/68/EWG
- Normativa per bassa tensione (73/23/EWG) - 93/68/EWG
- Normativa ce per certificatione 93/68/EWG

Conforme con los requerimientos de las siguientes Guias de la CE:

- **CE-Maquina estandar (89/392/EWG)i.d.F.91/368/EWG,93/44EWG,93/68/EWG73/23/EWG**
- **Guia EC para compatibilidad electro magn,tica (89/336/EWG) - 93/68/EWG**
- **Guia EC para bajo volaje (73/23/EWG) - 93/68/EWG**
- **Guia EC para certificaciñ de la CE 93/68/EWG**

Em conformidade com os seguintes Regulamentos CE:

- CE-Maquina estandar (89/392/EWG)i.d.F.91/368/EWG,93/44EWG,93/68/EWG73/23/EWG
- Regulamento CE para compatibilidade electro-magn,tica(89/336/EWG - 93/68/EWG
- Regulamento CE para a baixa voltagem (73/23/EWG) - 93/68/EWG
- Regulamento CE para o certificado CE 93/68/EWG

Conform de Bepaligen van de EG-Richtlijnen:

- **EG-Machinerichtlijn (89/392/EWG)i.d.F.91/368/EWG,93/44EWG,93/68/EWG73/23/EWG**
- **EG Richtlijn elektromagnetische storings gevoeligheid (89/336/EWG) - 93/68/EWG**
- **EG Laagspannings-Richtlijn (73/23/EWG) - 93/68/EWG**
- **EG Richtlijn CE-Markering CE 93/68/EWG**

I enlighet med EC följande väglednings föreskrifter:

- EC Maskindirektivet (89/392/EWG)i.d.F.91/368/EWG,93/44EWG,93/68/EWG73/23/EWG
- EC vägledning för electro-magnetisk förenlighet med (89/336/EWG) - 93/68/EWG
- EC lag volts vägledning (73/23/EWG) - 93/68/EWG
- EC vägledning för CE certifikat CE 93/68/EWG

Angewandte harmonisierte Normen, insbesondere: Applied harmonious norms, in particular: Application de l'harmonie d'une norme: Norme particolari applicate: Normas aplicadas, en particular: Normas de harmonia particulares aplicadas: Toegepaste geharmoniseerde normen, in het bijzonder: Tillverkad i följande harmoniserande normer:

**EN 60204-1; EN 292-1; EN 292-2, EN 294
EN 50081 Teil 1; EN 50082 Teil 1; EN 55022 Kl.B**

Datum: Date: Data: Fecha: 09.08.1997

Hersteller-Unterschrift: Signature of the manufacturer: Signature du constructeur: Firma del costruttore: Firma del fabricante: Assinatura do fabricante: Handtekening van de fabrikant: Tillverkarens signatur:



ppa. D.Eberhartinger

Angaben zum Unterzeichner: Particulars of the undersigned: Fonction du signataire: Particolarità della controfirma: Detalles del firmante: Cargo do responsável: Details van de ondertekenaar: Namnförtydligande

Prokurist/Authorised Signatory



GS-Prüfbescheinigung

984107

Bescheinigungs-Nummer

Name und Anschrift
des Bescheinigungsinhabers:
(Auftraggeber) Beissbarth GmbH
Automobil-Servicegeräte
Hanauer Straße 101, 80993 München

Name und Anschrift
des Herstellers: dto.

Zeichen des Auftraggebers: Ho/Ko Zeichen der Prüf- und Zertifizierungsstelle: fea 652.34/538/242 scn-schj Ausstellungsdatum: 22.10.1998

Produktbezeichnung: Radauswuchtcomputer

Typ: microtec 870, microtec 880

Bestimmungsgemäße
Verwendung: ---

Prüfgrundlage: Grundsätze für die Prüfung und Zertifizierung von Fahrzeuginstandhaltungs-
und Fahrzeugprüfmaschinen und -geräten (GS-EM I 04, 06.1997)
mit Anlagen 1, 5 und 10

Bemerkungen: ---

Das geprüfte Baumuster stimmt mit den in § 3 Absatz 1 des Gerätesicherheitsgesetzes genannten Anforderungen überein. Das Baumuster entspricht somit auch den einschlägigen Bestimmungen der Richtlinie 89/392/EWG (Maschinen), geändert durch die Richtlinien 91/368/EWG, 93/44/EWG und 93/68/EWG. Der Bescheinigungsinhaber ist berechtigt, das umseitig abgebildete GS-Zeichen an den mit dem geprüften Baumuster übereinstimmenden Produkten anzubringen. Der Bescheinigungsinhaber hat dabei die umseitig aufgeführten Bedingungen zu beachten. Diese Bescheinigung einschließlich der Berechtigung zur Anbringung des GS-Zeichens wird spätestens ungültig am:

31.12.2003

Weiteres über die Gültigkeit, eine Gültigkeit und andere Bedingungen regelt die Prüf- und Zertifizierungsordnung vom Januar 1993



Dr.-Ing. Ernst-Otto Siegmann
.....
Unterschrift (Dr.-Ing. Ernst-Otto Siegmann)

GS-Zeichen



Normalausführung



Bei einer Höhe von 20 mm oder weniger
auch zulässige Ausführung

¹⁾ Bescheinigungs-Nummer

-
1. Der Bescheinigungsinhaber hat die Voraussetzungen einzuhalten, die bei der Herstellung des umseitig genannten Produktes zu beachten sind, um die Übereinstimmung mit dem geprüften Baumuster zu gewährleisten.
 2. Die Prüf- und Zertifizierungsstelle der Fachausschüsse Eisen und Metall I und Oberflächenbehandlung führt in regelmäßigen Abständen Kontrollmaßnahmen zur Überwachung der Herstellung und rechtmäßigen Verwendung des GS-Zeichens durch.
 3. Die für die Herstellung verantwortliche Person hat sich zur Einhaltung der Voraussetzungen nach Nummer 1 und Duldung der Kontrollmaßnahmen verpflichtet.
 4. Die Prüf- und Zertifizierungsstelle entzieht dem Bescheinigungsinhaber die Zuerkennung des GS-Zeichens, wenn sich die Anforderungen nach § 3 Absatz 1 des Gerätesicherheitsgesetzes geändert haben oder die Voraussetzungen nach Nummer 1 nicht eingehalten werden.
 5. Das GS-Zeichen darf nur verwendet und mit ihm darf nur geworben werden, wenn die Voraussetzungen nach § 3 Absatz 4 Satz 1 des Gerätesicherheitsgesetzes erfüllt sind.

Die Gültigkeit der Prüfbescheinigung (Nummer 984107) wird verlängert bis

.....
Datum

.....
Unterschrift

